

Dell PowerEdge R860

Technical Guide

Notes, cautions, and warnings

 **NOTE:** A NOTE indicates important information that helps you make better use of your product.

 **CAUTION:** A CAUTION indicates either potential damage to hardware or loss of data and tells you how to avoid the problem.

 **WARNING:** A WARNING indicates a potential for property damage, personal injury, or death.

Contents

Chapter 1: Dell PowerEdge R860 system overview.....	5
Key workloads.....	5
New technologies.....	5
Chapter 2: System features and generational comparison.....	7
Chapter 3: Chassis views and features.....	10
Front view of the system.....	10
Rear view of the system.....	11
Inside the system.....	12
Chapter 4: Processor.....	19
Processor features	19
Supported processors.....	19
Chapter 5: Memory subsystem.....	20
Supported memory.....	20
Chapter 6: Storage.....	21
Storage controllers.....	21
Supported Drives.....	21
Internal storage configuration.....	22
External Storage.....	22
Chapter 7: Networking.....	23
Overview.....	23
OCP 3.0 support.....	23
Supported OCP cards.....	23
OCP NIC 3.0 vs. rack Network Daughter Card comparisons.....	24
Chapter 8: PCIe subsystem.....	25
PCIe risers.....	25
Chapter 9: Power, thermal, and acoustics.....	31
Power.....	31
Power Supply Units.....	32
Thermal.....	33
Thermal design.....	33
Acoustics.....	34
Acoustical performance.....	34
Chapter 10: Rack, rails, and cable management.....	36
Rails and cable management information.....	36

Chapter 11: Operating Systems and Virtualization.....	45
Supported operating systems.....	45
Chapter 12: Dell OpenManage Systems Management.....	46
Integrated Dell Remote Access Controller (iDRAC).....	46
Systems Management software support matrix.....	47
Chapter 13: Appendix D: Service and support.....	49
Default support levels.....	49
Default deployment levels.....	49
Other services and support information.....	49
ProDeploy Infrastructure Suite.....	49
Dell custom deployment Services.....	52
Dell Residency Services.....	52
Dell Data Migration Services.....	52
Dell Enterprise Support Services.....	52
Enterprise connectivity.....	55
Dell TechDirect.....	56
Dell Technologies Consulting Services.....	56
Chapter 14: Appendix A: Additional specifications.....	58
Chassis dimensions	58
Chassis weight.....	59
NIC port specifications.....	59
Video specifications.....	59
USB Ports.....	60
PSU rating.....	61
Environmental specifications.....	62
Thermal restriction matrix.....	64
Thermal air restrictions.....	67
Chapter 15: Appendix B. Standards compliance.....	69
Chapter 16: Appendix C Additional resources.....	70

Dell PowerEdge R860 system overview

The PowerEdge R860 system is a 2U server that supports:

- Up to 4 x 4th Gen Intel® Xeon® Scalable Processors with up to 60 cores
- 64 DDR5 DIMM slots, supports maximum 16 TB
- Two AC or DC power supply units with 1+1 redundancy
- Up to 8 x 2.5-inch SAS/SATA (HDD/SSD) drives
- Up to 8 x EDSFF E3.S NVMe Gen5 (SSD) drives
- Up to 16 x 2.5-inch SAS/SATA/NVMe (HDD/SSD) drives
- Up to 24 x 2.5-inch SAS/SATA/NVMe (HDD/SSD) drives
- Up to 16 x 2.5-inch SAS/SATA (HDD/SSD) + 8 x 2.5-inch NVMe (SSD) drives
- Up to 24 x 2.5-inch SAS/SATA (HDD/SSD) + 2 x 2.5-inch (rear) SAS/SATA/NVMe (HDD/SSD) or 4 x EDSFF E3.S (rear) NVMe Gen5 (SSD) drives
- PCI Express® (PCIe) 5.0 enabled expansion slots
- Network interface technologies to cover Network Interface Card (NIC)

NOTE: For more information about how to hot swap NVMe PCIe SSD U.2 device, see the *Dell Express Flash NVMe PCIe SSD User's Guide* at [Dell Support > Browse all products > Infrastructure > Data Center Infrastructure > Storage Adapters & Controllers > Dell PowerEdge Express Flash NVMe PCIe SSD > Select This Product > Documentation > Manuals and Documents](#).

NOTE: All instances of SAS, SATA, NVMe drives are referred to as drives in this document, unless specified otherwise.

CAUTION: Do not install GPUs, network cards, or other PCIe devices on your system that are not validated and tested by Dell. Damage caused by unauthorized and invalidated hardware installation will null and void the system warranty.

Topics:

- [Key workloads](#)
- [New technologies](#)

Key workloads

Customers looking for accelerated compute to maximize performance in a dense, scalable server architecture to address the following applications:

- SAP/HANA, Oracle, SQL
- Database, ERP, CRM, batch
- Data warehouse, business intelligence
- Virtualization/VM and VDI
- AI, HPC and ML/DL

New technologies

Table 1. New technologies

Technology	Detailed Description
4 th Generation Intel® Xeon® Scalable Processors	Core count: Up to 60 core processor
	UPI speed: Up to 4 links per CPU, speed: 12.8 GT/s, 14.4 GT/s, 16 GT/s

Table 1. New technologies (continued)

Technology	Detailed Description
	Maximum number of PCIe lanes per CPU: Integrated 80 PCIe 5.0 lanes @ 32 GT/s PCIe Gen5
	Maximum TDP: 350 W
5600 MT/s DDR5 Memory	Max 16 DIMM per processor and 64 DIMMs per system
	Supports DDR5 ECC RDIMM
PCIe Gen	Gen5 @32 GT/s
PCIe Slot	Up to eight Gen5 (x16) slots
Flex I/O	LOM board, 2 x1Gb with BCM5720 LAN controller (optional)
	Rear I/O with: <ul style="list-style-type: none"> ● 1 x Dedicated iDRAC Ethernet port ● 1 x USB 3.0 ● 1 x USB 2.0 ● 1 x VGA port (optional for Direct Liquid Cooling configuration)
	Serial Port (option) with STD RIO board
	OCP Mezz 3.0 (supported by x168 PCIe lanes) (optional)
	Front I/O with: <ul style="list-style-type: none"> ● 1 x USB 2.0 ● 1 x iDRAC Direct (Micro-AB USB) port ● 1 x VGA port
CPLD 1-wire	Support payload data of Front PERC, Riser, BP, and Rear I/O to BOSS N1 and iDRAC.
Dedicated PERC	PERC 11 <ul style="list-style-type: none"> ● H355, H755
	PERC 12 <ul style="list-style-type: none"> ● H965i, H965e
Software RAID	OS RAID/S160
Power Supplies	60 mm dimension is the new PSU form factor on a 15G design.
	Titanium 1100 W AC/HVDC Platinum 1400 W AC/HVDC Titanium 1800 W AC/HVDC
	86 mm dimension PSU
	Platinum 2400 W AC/HVDC Titanium 2800 W AC/HVDC

System features and generational comparison

The following table shows the comparison between the PowerEdge R860 with the PowerEdge R840.

Table 2. Features comparison

Features	PowerEdge R860	PowerEdge R840
Processors	4 x 4 th Gen Intel® Xeon® Scalable Processors	4 x 2 nd Generation Intel® Xeon® Scalable Processor
Processor interconnect	Intel Ultra Path Interconnect (UPI)	Intel Ultra Path Interconnect (UPI)
Memory	<ul style="list-style-type: none"> 64 x DDR5 RDIMM Up to 4800 MT/s (1 DPC) / 4400 MT/s (2 DPC) 	<ul style="list-style-type: none"> 48 x DDR4 DIMM RDIMM /LRDIMM 24 x PMem (Intel Optane Persistent Memory) 12 x NVDIMM
Storage Controllers	<ul style="list-style-type: none"> PERC 11G: H755, H355 PERC 12G: H965i, H965e HBA 11: HBA355i, HBA355e HBA 12: HBA 465i, HBA 465e BOSS-N1 Software RAID: S160 	<ul style="list-style-type: none"> PERC 9G: H330, H730p PERC 10G: H740p, H840 HBA 9: HBA330, 12 Gbps SAS HBA BOSS adapter Software RAID: S140 Internal Dual SD Module
Drive Bays	<p>Front bays:</p> <ul style="list-style-type: none"> 2.5 inches - 24 Gb SAS, 6 Gb SATA 2.5 inches - Gen3/4 NVMe EDSFF E3.S - NVMe Gen5 <p>Rear bay:</p> <ul style="list-style-type: none"> 2.5 inches - 24 Gb SAS, 6 Gb SATA, Gen3/4 NVMe EDSFF E3.S - NVMe Gen5 	<p>Front bays:</p> <ul style="list-style-type: none"> 2.5 inches - 24 Gb SAS, 6 Gb SATA 2.5 inches - Gen3/4 NVMe <p>Rear bay:</p> <ul style="list-style-type: none"> 2.5 inches - 12 Gb SAS, 6 Gb SATA
Power Supplies	<ul style="list-style-type: none"> AC (Platinum): 1400 W, 2400 W AC (Titanium): 1100 W, 1800 W, 2800 W 	<ul style="list-style-type: none"> AC (Platinum): 750 W, 1100 W, 1600 W, 2000 W, 2400 W AC (Titanium): 1600 W, 2600 W LVDC @-48 VDC Input: 1100 W
Cooling Options	<ul style="list-style-type: none"> Air Cooling Optional Direct Liquid Cooling (DLC) <p>i NOTE: DLC is a rack solution and requires rack manifolds and a cooling distribution unit (CDU) to operate.</p>	<ul style="list-style-type: none"> Air Cooling
Fans	<p>Standard (STD) fans</p> <p>Up to 6 sets (dual fan module) hot plug fans</p>	<p>Standard (STD) fans</p> <p>Up to six hot plug fans</p>
Dimension	<p>Height: 86.8 mm (3.41 inches)</p> <p>Width: 482 mm (18.97 inches)</p> <p>Depth: 883.2 mm (34.77 inches) with bezel</p>	<p>Height: 86.8 mm (3.4 inches)</p> <p>Width: 434.0 mm (17.08 inches)</p> <p>Depth: 879.8 mm (34.63 inches) with bezel</p>

Table 2. Features comparison (continued)

Features	PowerEdge R860	PowerEdge R840				
	Depth: 869.2 mm (34.22 inches) without bezel	Depth: 865.9 mm (34.09 inches) without bezel				
Form Factor	2U rack server	2U rack server				
Embedded Management	<ul style="list-style-type: none"> • iDRAC9 • iDRAC Direct • iDRAC RESTful API with Redfish • iDRAC Service Manual • Quick Sync 2 wireless module 	<ul style="list-style-type: none"> • iDRAC9 • iDRAC Direct • Quick Sync 2 BLE/wireless module 				
Bezel	Optional LCD bezel or security bezel	Optional LCD bezel or security bezel				
OpenManage Software	<ul style="list-style-type: none"> • CloudIQ for PowerEdge plug-in • OpenManage Enterprise • OpenManage Enterprise Integration for VMware vCenter • OpenManage Integration for Microsoft System Center • OpenManage Integration with Windows Admin Center • OpenManage Power Manager plug-in • OpenManage Services plug-in • OpenManage Update Manager plug-in 	<ul style="list-style-type: none"> • OpenManage Enterprise • OpenManage Power Center 				
Mobility	OpenManage Mobile	OpenManage Mobile				
Integrations and Connections	OpenManage Integrations <ul style="list-style-type: none"> • BMC Truesight • Microsoft System Center • OpenManage Integration with ServiceNow • Red Hat Ansible Modules • Terraform Providers • VMware vCenter and vRealize Operations Manager 	<table border="1"> <tr> <td> OpenManage Integrations <ul style="list-style-type: none"> • BMC Truesight ® • Microsoft System Center • Red Hat Ansible Modules • VMware vCenter </td> <td> OpenManage Connections <ul style="list-style-type: none"> • IBM Tivoli Netcool/OMNIBus • Micro Focus Operations Manager • Nagios® Core and Nagios® XI </td> </tr> </table>	OpenManage Integrations <ul style="list-style-type: none"> • BMC Truesight ® • Microsoft System Center • Red Hat Ansible Modules • VMware vCenter 	OpenManage Connections <ul style="list-style-type: none"> • IBM Tivoli Netcool/OMNIBus • Micro Focus Operations Manager • Nagios® Core and Nagios® XI 		
OpenManage Integrations <ul style="list-style-type: none"> • BMC Truesight ® • Microsoft System Center • Red Hat Ansible Modules • VMware vCenter 	OpenManage Connections <ul style="list-style-type: none"> • IBM Tivoli Netcool/OMNIBus • Micro Focus Operations Manager • Nagios® Core and Nagios® XI 					
Security	<ul style="list-style-type: none"> • Cryptographically signed firmware • Data at Rest Encryption (SEDs with local or external key mgmt) • Secure Boot • Secured Component Verification (Hardware integrity check) • Secure Erase • Silicon Root of Trust • System Lockdown (requires iDRAC9 Enterprise or Datacenter) • TPM 2.0 FIPS, CC-TCG certified, TPM 2.0 China NationZ 	<ul style="list-style-type: none"> • Cryptographically signed firmware • Secure Boot • Secure Erase • Silicon Root of Trust • System Lockdown (requires iDRAC9 Enterprise or Datacenter) • TPM 1.2/2.0, TCM 2.0 optional 				
Embedded NIC	2 x 1GbE LOM card (optional)	4 x 1GbE Network Daughter Card (optional)				
Networking Options	OCP x16 (optional) Mezz 3.0  NOTE: The system allows either LOM card or OCP card or both to be installed in the system.	N/A				
GPU Options	N/A	Up to 2 double width GPUs or up to 2 full height FPGAs				
Ports	<table border="1"> <tr> <td>Front Ports</td> <td>Rear Ports</td> </tr> </table>	Front Ports	Rear Ports	<table border="1"> <tr> <td>Front Ports</td> <td>Rear Ports</td> </tr> </table>	Front Ports	Rear Ports
Front Ports	Rear Ports					
Front Ports	Rear Ports					

Table 2. Features comparison (continued)

Features	PowerEdge R860	PowerEdge R840
	<ul style="list-style-type: none"> ● 1 x USB 2.0 ● 1 x VGA ● 1 x Dedicated iDRAC micro-USB 	<ul style="list-style-type: none"> ● 1 x USB 2.0 ● 1 x iDRAC Direct/Ethernet port ● 1 x USB 3.0 ● 1 x Serial port (optional) ● 1 x VGA (optional for liquid cooling configuration)
	Internal Port: 1 x USB 3.0	Internal Port: 1 x USB 3.0
PCIe	Up to 8 x PCIe slots <ul style="list-style-type: none"> ● 8 x PCIe Gen5 slots ● 4 x PCIe Gen4 slots 	Up to 6 x PCIe Gen3 slots
Operating System and Hypervisors	<ul style="list-style-type: none"> ● Canonical Ubuntu Server LTS ● Microsoft Windows Server with Hyper-V ● Red Hat Enterprise Linux ● SUSE Linux Enterprise Server ● VMware ESXi For specifications and interoperability details, see Dell Enterprise Operating Systems on Servers, Storage, and Networking page at Dell.com/OSsupport .	<ul style="list-style-type: none"> ● Canonical Ubuntu Server LTS ● Citrix Hypervisor ● Microsoft Windows Server LTSC with Hyper-V ● Red Hat Enterprise Linux ● VMware ESXi For specifications and interoperability details, see Dell Enterprise Operating Systems on Servers, Storage, and Networking page at Dell.com/OSsupport .

Chassis views and features

Topics:

- Front view of the system
- Rear view of the system
- Inside the system

Front view of the system



Figure 1. Front view of 24 x 2.5-inch drive system

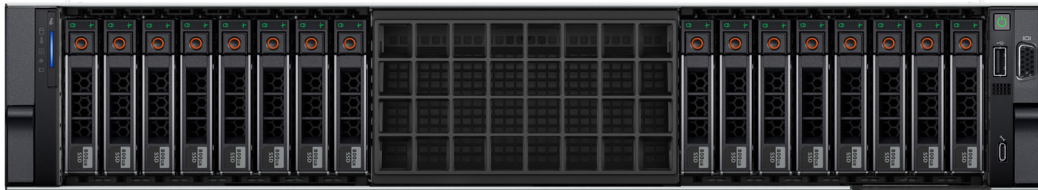

Figure 2. Front view of 16 x 2.5-inch drive system

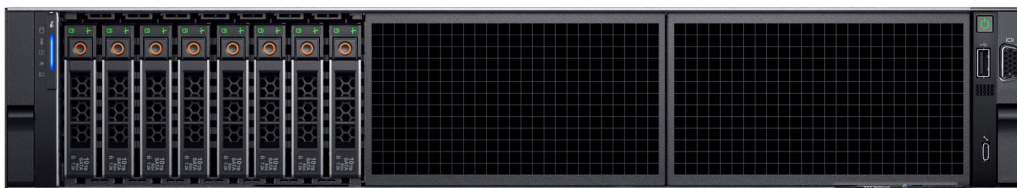

Figure 3. Front view of 8 x 2.5-inch drive system

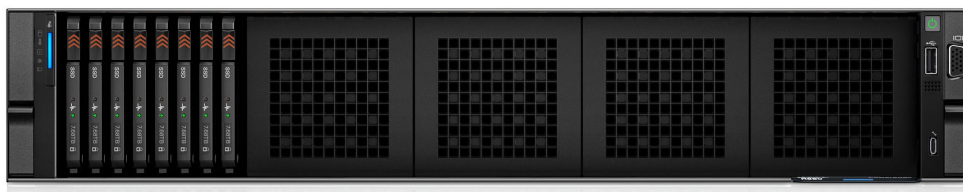

Figure 4. Front view of 8 x EDSFF E3.S drive system

Rear view of the system



Figure 5. Rear view of the system



Figure 6. Rear view of the system with 2 x 2.5-inch drive system



Figure 7. Rear view of the system with 4 x EDSFF E3.S drive system



Figure 8. Rear view of the system with Direct Liquid Cooling

Inside the system

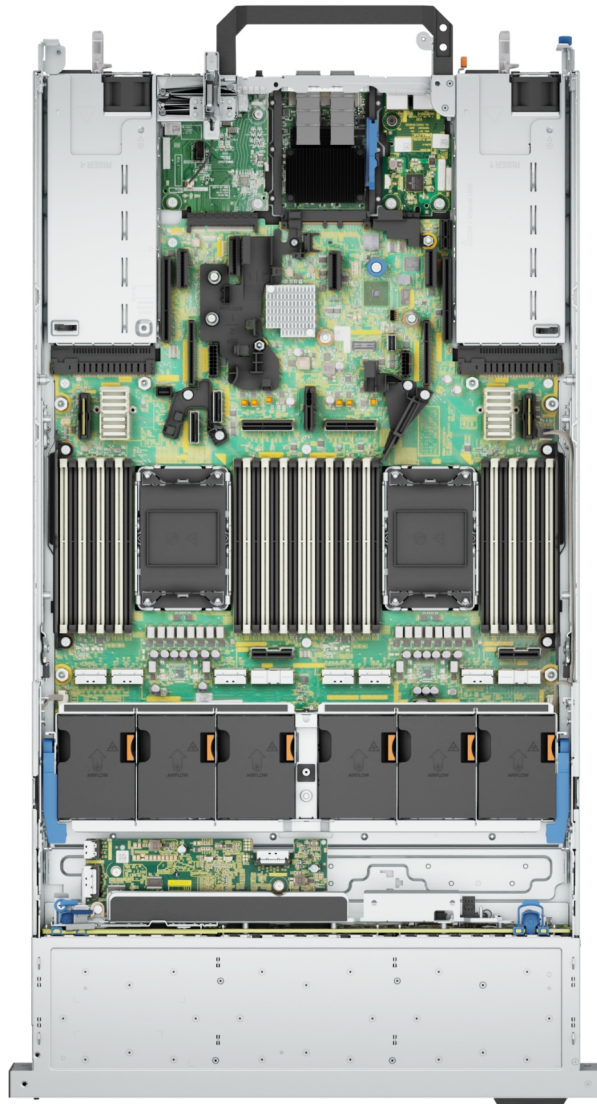

Figure 9. Inside the system without risers

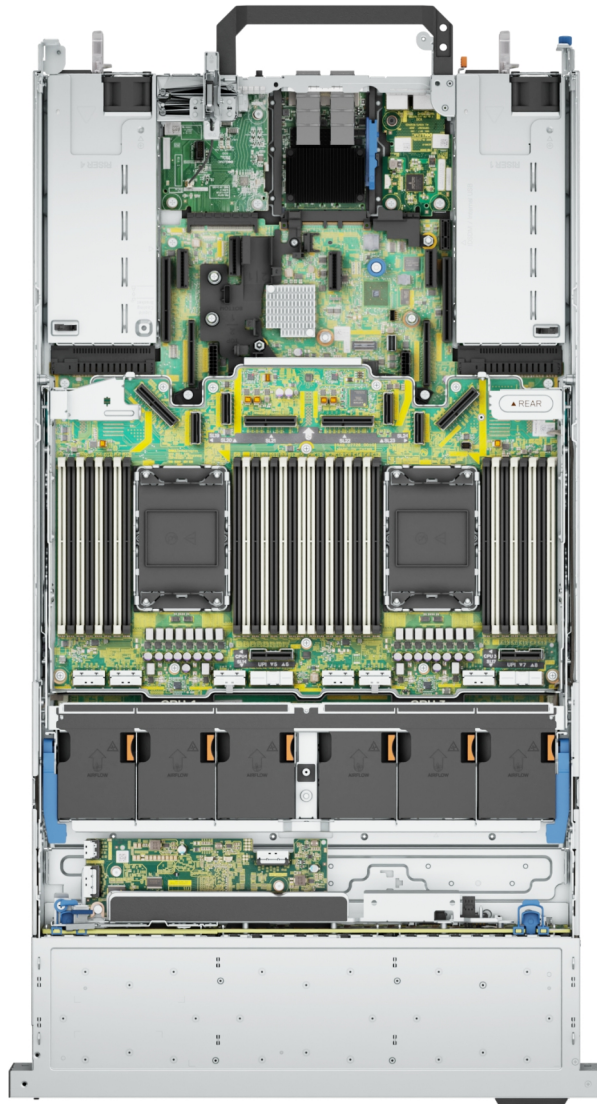

Figure 10. Inside the system without risers (PEM board installed)

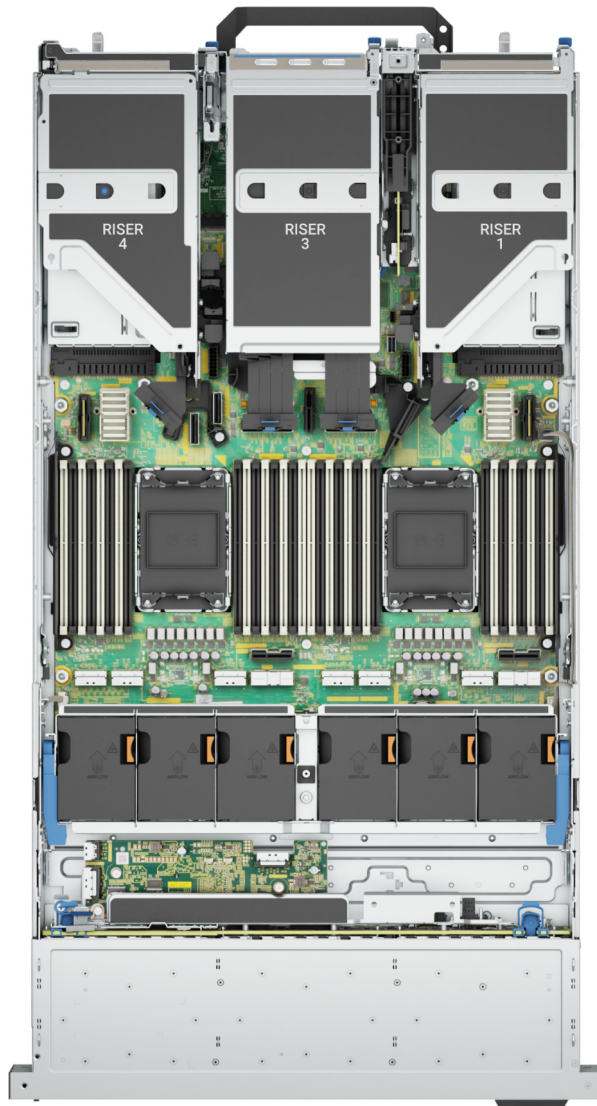

Figure 11. Inside the system with risers

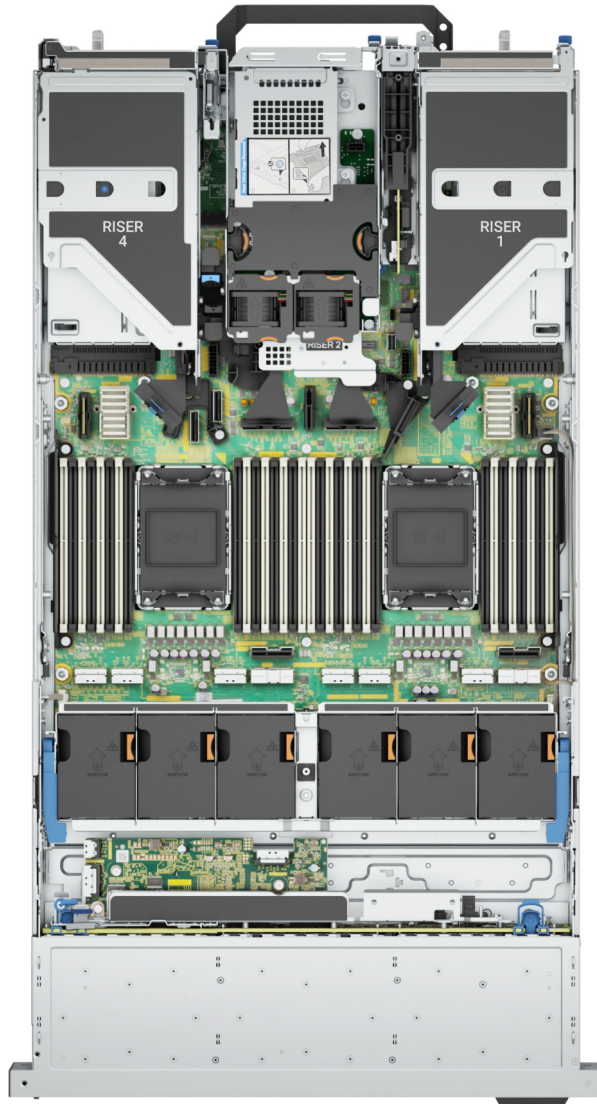

Figure 12. Inside the system with risers + rear 2 x 2.5-inch module

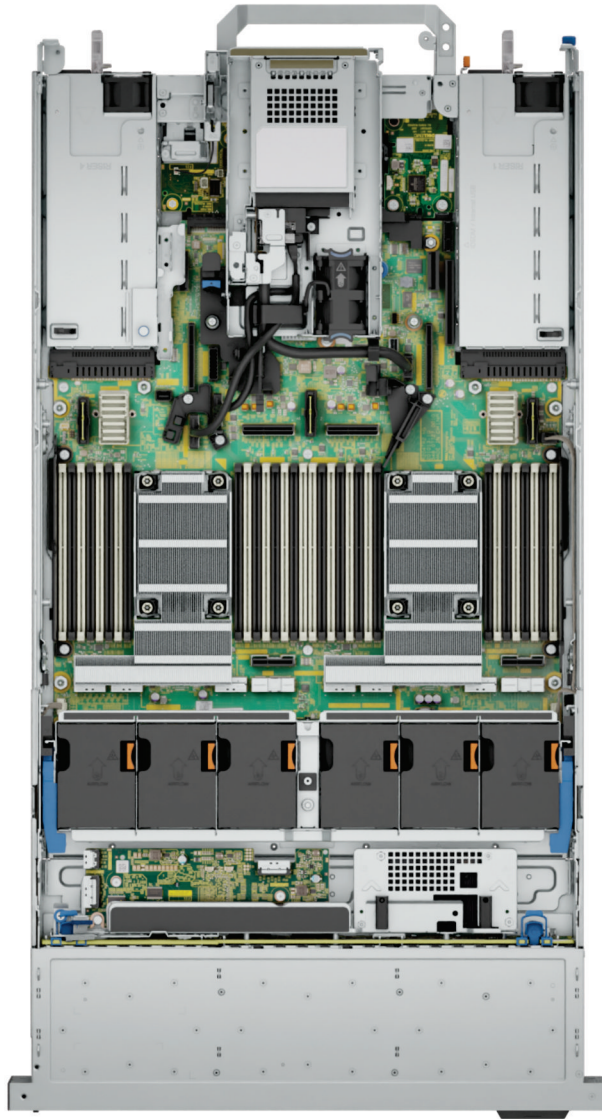

Figure 13. Inside the system with risers + rear 4 x EDSFF E3.S drive module

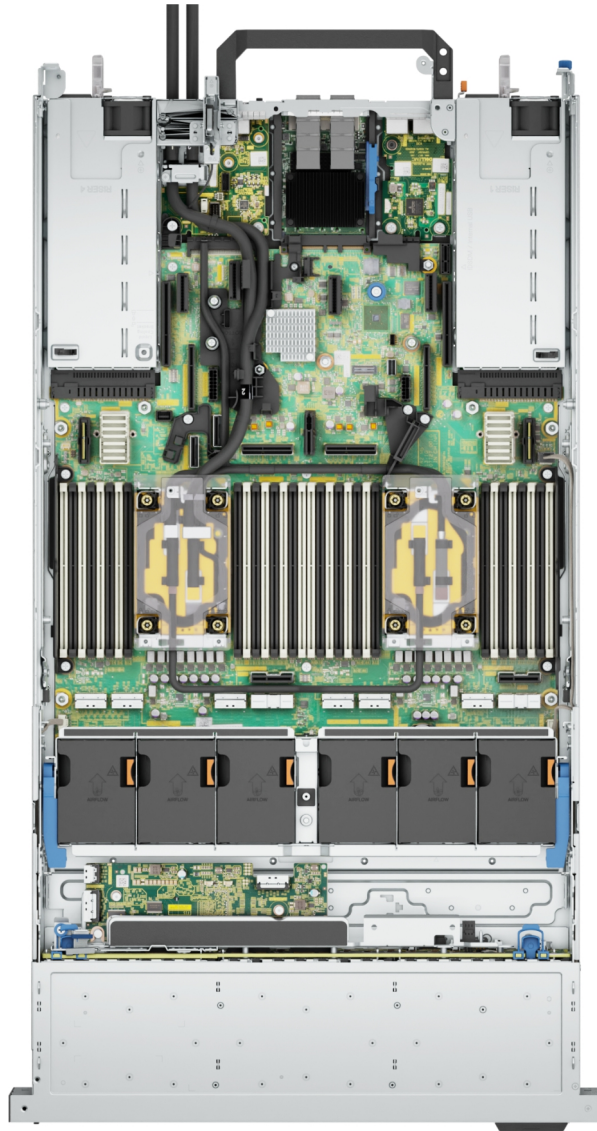

Figure 14. Inside the system with Direct Liquid Cooling module

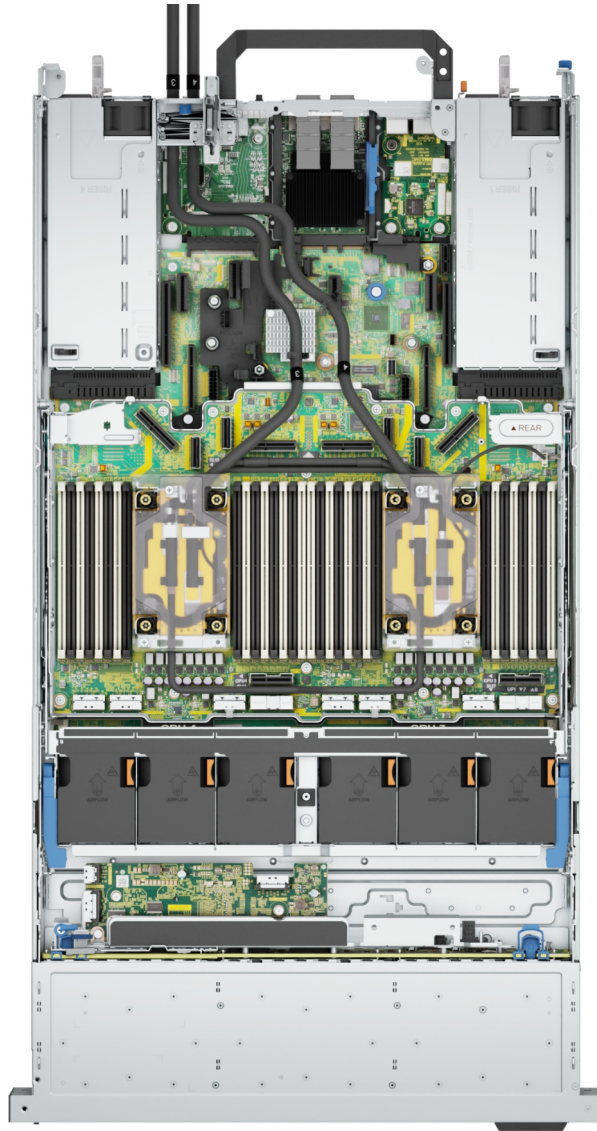

Figure 15. Inside the system with Direct Liquid Cooling module (PEM board installed)

Processor

Topics:

- [Processor features](#)

Processor features

The 4th Generation Intel® Xeon® Processors stack is the next generation data center processor offering with significant performance increases, integrated acceleration, and next generation memory and I/O. Sapphire Rapids accelerate customer usages with unique workload optimizations.

The following lists the features and functions that are in the 4th Generation Intel® Xeon® Scalable Processor offering:

- Faster UPI with up to four Intel Ultra Path Interconnect (Intel UPI) at up to 16 GT/s, increasing multisocket bandwidth
- More, faster I/O with PCI Express 5 and up to 80 lanes (per socket)
- Enhanced Memory Performance with DDR5 support and memory speed up to 4800 MT/s in one DIMM per channel (1DPC) and 4400 MT/s in two DIMM per channel (2DPC)
- New built-in accelerators for data analytics, networking, storage, crypto, and data compression

Supported processors

The following table shows the Intel Sapphire Rapids SKUs that are supported on the R8960.

Table 3. Supported Processors for R860

Processor	Clock Speed (GHz)	Cache (M)	UPI (GT/s)	Cores	Threads	Turbo	Memory Speed (MT/s)	Memory Capacity	TDP
8490H ¹	1.9	113	16	60	120	Turbo	4800	4 TB	350 W
8468H ¹	2.1	105	16	48	96	Turbo	4800	4 TB	330 W
8460H ¹	2.2	105	16	40	80	Turbo	4800	4 TB	330 W
8454H ¹	2.1	83	16	32	64	Turbo	4800	4 TB	270 W
8450H ¹	2	75	16	28	56	Turbo	4800	4 TB	250 W
8444H ¹	2.9	45	16	16	32	Turbo	4800	4 TB	270 W
6448H	2.4	60	16	32	64	Turbo	4800	4 TB	250 W
6434H	3.7	23	16	8	16	Turbo	4800	4 TB	195 W
6418H	2.1	60	16	24	48	Turbo	4800	4 TB	185 W
6416H	2.2	45	16	18	36	Turbo	4800	4 TB	165 W

NOTE: Mixing of the processors in a 4S configurations is not recommended.

NOTE: ¹ Only the processors that are listed above can support 96 GB RDIMM.

Memory subsystem

Topics:

- Supported memory

Supported memory

Table 4. Memory technology comparison

Feature	PowerEdge R860 (DDR5)
DIMM type	RDIMM
Transfer speed	4800 MT/s (1DPC), 4400 MT/s (2DPC)
Voltage	1.1 V

Table 5. Supported memory matrix

DIMM type	Rank	Capacity	DIMM rated voltage and speed	Operating Speed	
				1 DIMM per channel (DPC)	2 DIMMs per channel (DPC)
RDIMM	1 R	16 GB	DDR5 (1.1 V), 4800 MT/s or 5600 MT/s	4800 MT/s	4400 MT/s
	2 R	32 GB, 64 GB	DDR5 (1.1 V), 4800 MT/s or 5600 MT/s	4800 MT/s	4400 MT/s
	2 R	96 GB	DDR5 (1.1 V), 5600 MT/s	4800 MT/s	4400 MT/s
	4 R	128 GB	DDR5 (1.1 V), 4800 MT/s	4800 MT/s	4400 MT/s
	8 R	256 GB	DDR5 (1.1 V), 4800 MT/s	4800 MT/s	4400 MT/s

NOTE: The processor may reduce the performance of the rated DIMM speed.

NOTE: Only 8 or 16 DIMMs per processor are compatible with 96 GB RDIMMs.

NOTE: Few processors that are listed in the [supported processors](#) section support 96 GB RDIMM.

Storage

Topics:

- Storage controllers
- Supported Drives
- Internal storage configuration
- External Storage

Storage controllers

Dell's RAID controller options offer performance improvements, including the fPERC solution. fPERC provides a base RAID HW controller without consuming a PCIe slot by using a small form factor and high-density connector to the base planar. 16G PERC Controller offerings will be a heavy leverage of 15G PERC family. The Value and Value Performance levels will carry over to 16G from 15G. New to 16G, is the Harpoon-based Premium Performance tier offering. This high-end offering will drive IOPs performance and enhanced SSD performance.

Table 6. PERC Series controller offerings

Performance Level	Controller and Description
Entry	S160
Value	H355, HBA355 (internal/external), HBA465 (internal/external)
Value Performance	H755
Premium Performance	H965 (internal/external)

NOTE: For more information on the features of the Dell PowerEdge RAID controllers (PERC), Software RAID controllers, or BOSS card, and on deploying the cards, see the storage controller documentation at [Storage Controller Manuals](#).

NOTE: From December 2021, H355 replaces H345 as the entry raid controller. H345 is deprecated in January 2022.

Supported Drives

The table that is shown below lists the internal drives that are supported by the R860.

Table 7. Supported drives

Form Factor	Type	Speed	Rotational Speed	Capacities
2.5 inches	vSAS	12 Gb	SSD	1.92 TB, 3.84 TB, 960 GB, 7.62 TB
2.5 inches	SAS	24 Gb	SSD	1.92 TB, 1.6 TB, 800 GB, 3.84 TB, 960 GB, 7.68 TB
2.5 inches	SATA	6 Gb	SSD	1.92 TB, 480 GB, 960 GB, 3.84 TB
2.5 inches	NVMe	Gen4	SSD	1.6 TB, 3.2 TB, 6.4 TB, 1.92 TB, 3.84 TB, 15.63 TB, 7.68 TB, 800 GB, 400 GB
2.5 inches	DC NVMe	Gen4	SSD	3.84 TB, 960 GB
2.5 inches	SAS	12 Gb	10 K	600 GB, 1.2 TB, 2.4 TB

Table 7. Supported drives (continued)

Form Factor	Type	Speed	Rotational Speed	Capacities
EDSFF E3.S	NVMe	Gen5	SSD	3.84 TB, 7.68 TB

Internal storage configuration

R860 available internal storage configurations:

- 8 x 2.5-inch (SAS/SATA)
- 16 x 2.5-inch (SAS4/SATA)
- 16 x 2.5-inch (SAS4/SATA) + 8 x 2.5-inch NVMe
- 24 x 2.5-inch (SAS4/SATA)
- 24 x 2.5-inch (SAS4/SATA) + 2 x 2.5-inch (NVMe)
- 24 x 2.5-inch (SAS4/SATA) + 2 x 2.5-inch (SAS/SATA)
- 24 x 2.5-inch (SAS4/SATA) - Dual Controller
- 24 x 2.5-inch + 2 x 2.5-inch (SAS4/SATA) - Dual Controller
- 24 x 2.5-inch + 2 x 2.5-inch (SAS/SATA) - Dual Controller
- 24 x 2.5-inch (SAS4/SATA) + 4 x EDSFF E3.S NVMe Gen5
- 24 x 2.5-inch (NVMe) passive
- 16 x 2.5-inch (NVMe RAID)
- 8 x EDSFF E3.S (NVMe) Gen5

External Storage

The R860 support the external storage device types listed in the table below.

Table 8. Support external storage devices

Device Type	Description
External Tape	Supports connection to external USB tape products
NAS/IDM appliance software	Supports NAS software stack
JBOD	Supports connection to 12 Gb MD-series JBODs

Networking

Topics:

- [Overview](#)
- [OCP 3.0 support](#)

Overview

PowerEdge offers a wide variety of options to get information moving to and from our servers. Industry best technologies are chosen, and systems management features are added by our partners to firmware to tie in with iDRAC. These adapters are rigorously validated for worry-free, fully supported use in Dell servers.

OCP 3.0 support

Table 9. OCP 3.0 feature list

Feature	OCP 3.0
Form factor	SFF
PCIe Gen	Gen4
Max PCIe width	x16
Max number of ports	4
Port type	BT/SFP/SFP+/SFP28/SFP56/QSFP56
Max port speed	100 GbE
NC-SI	Yes
SNAPI	Yes
WoL	Yes
Power consumption	15 W ~ 35 W

Supported OCP cards

Table 10. Supported OCP cards

Form factor	Vendor	Port type	Port speed	Port count
OCP 3.0	Broadcom	SFP28	25 GbE	4
	Broadcom	SFP28	25 GbE	2
	Intel	SFP28	25 GbE	4
	Intel	SFP28	25 GbE	2
	Broadcom	BT	10 GbE	4
	Broadcom	SFP+	10 GbE	2

Table 10. Supported OCP cards (continued)

Form factor	Vendor	Port type	Port speed	Port count
	Broadcom	BT	1 GbE	4
	Intel	SFP+	1 GbE	4
	Broadcom	QSFP56	100 GbE	2
	Mellanox	QSFP56	100 GbE	2
	Mellanox	SFP28	25 GbE	2
	Intel	SFP+	1 GbE	4
	Intel	SFP+	10 GbE	4
	Intel	SFP+	10 GbE	2

OCP NIC 3.0 vs. rack Network Daughter Card comparisons

Table 11. OCP 3.0, 2.0, and rNDC NIC comparison

Form Factor	Dell rNDC	OCP 2.0 (LOM Mezz)	OCP 3.0	Notes
PCIe Gen	Gen 3	Gen 3	Gen 4	Supported OCP3 are SFF (small form factor)
Max PCIe Lanes	x8	Up to x16	Up to x8	See server slot priority matrix
Shared LOM	Yes	Yes	Yes	This is iDRAC port redirect
Aux Power	Yes	Yes	Yes	Used for Shared LOM

PCIe subsystem

Topics:

- PCIe risers

PCIe risers

Shown below are the riser offerings for the platform.

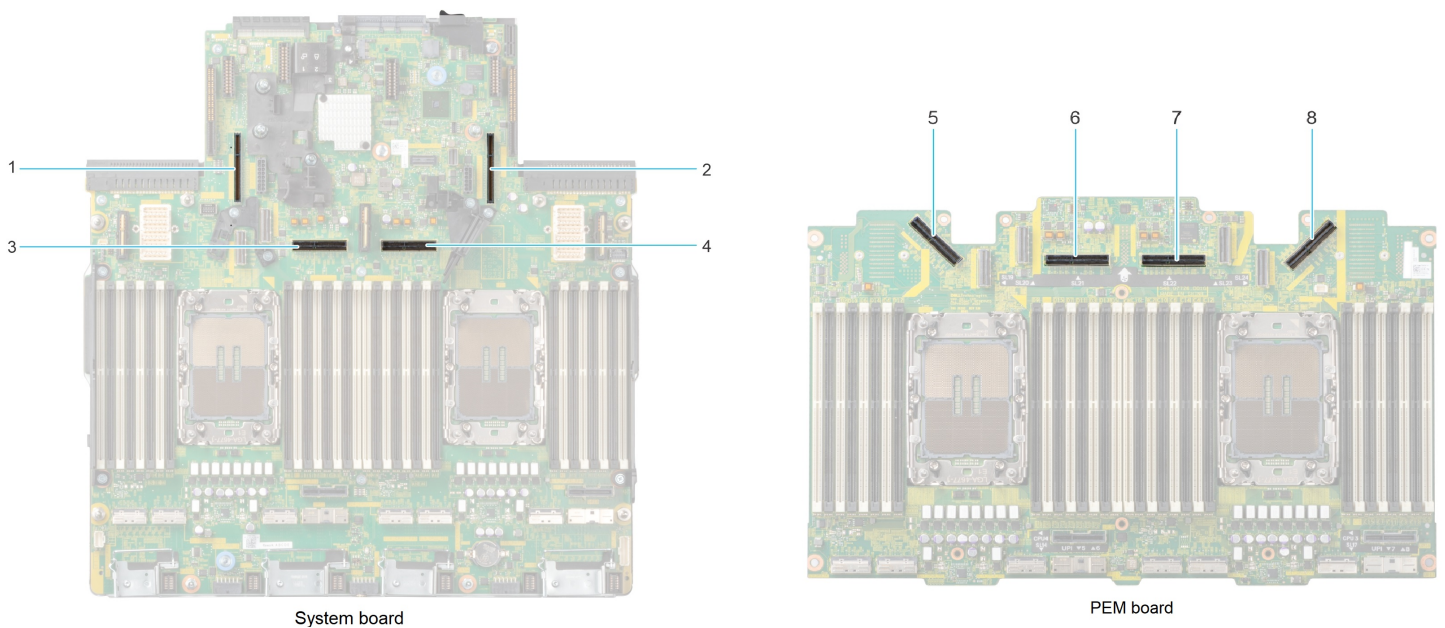

Figure 16. Riser connector location on system board and PEM board

- | | |
|-----------------------|-----------------------|
| 1. Riser 4 slot | 2. Riser 1 slot |
| 3. Riser 2 cable slot | 4. Riser 2 cable slot |
| 5. Riser 4 cable slot | 6. Riser 3 cable slot |
| 7. Riser 3 cable slot | 8. Riser 1 cable slot |

NOTE: A riser can be connected to the riser slot or riser cable slot or both depending on the type of riser used.

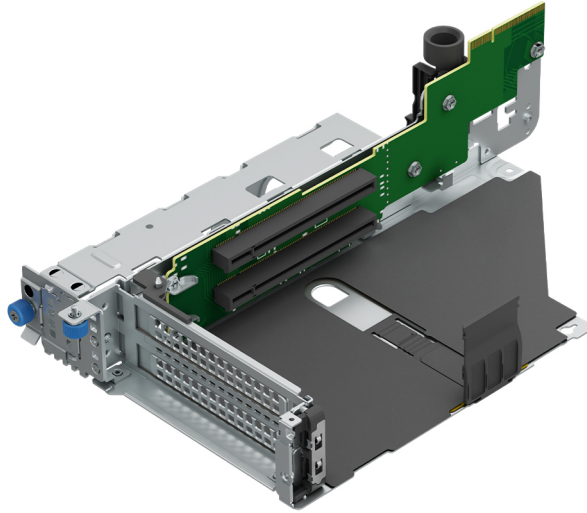

Figure 17. Riser 1B

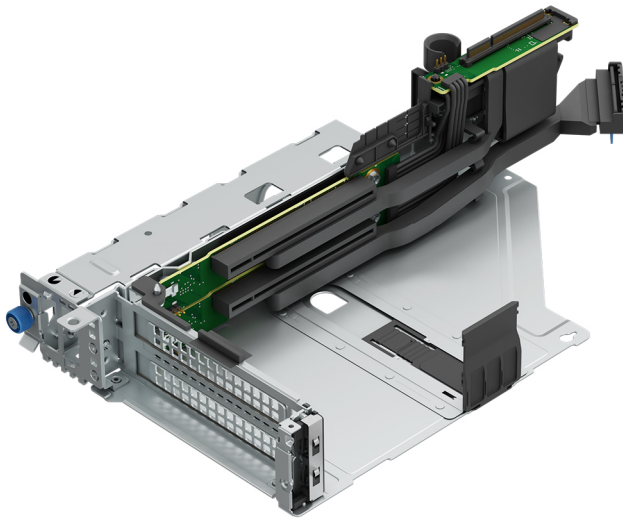

Figure 18. Riser 1C

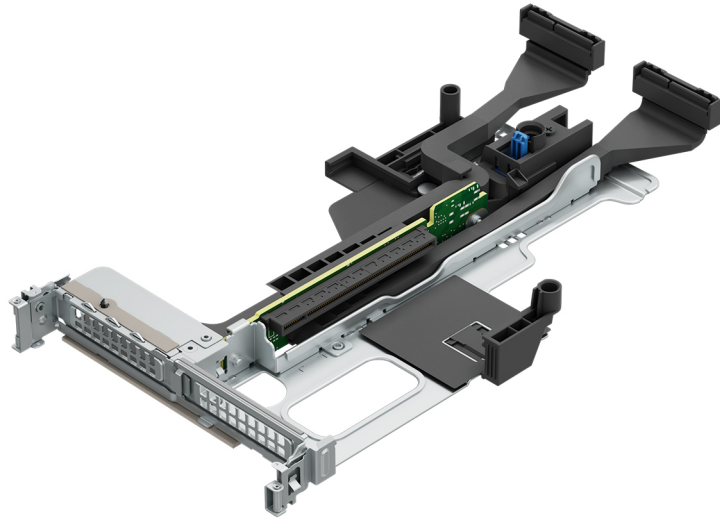

Figure 19. Riser 2

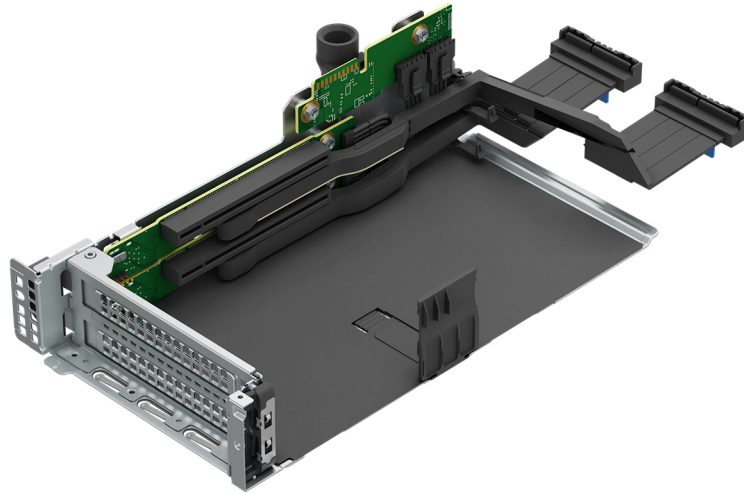

Figure 20. Riser 3

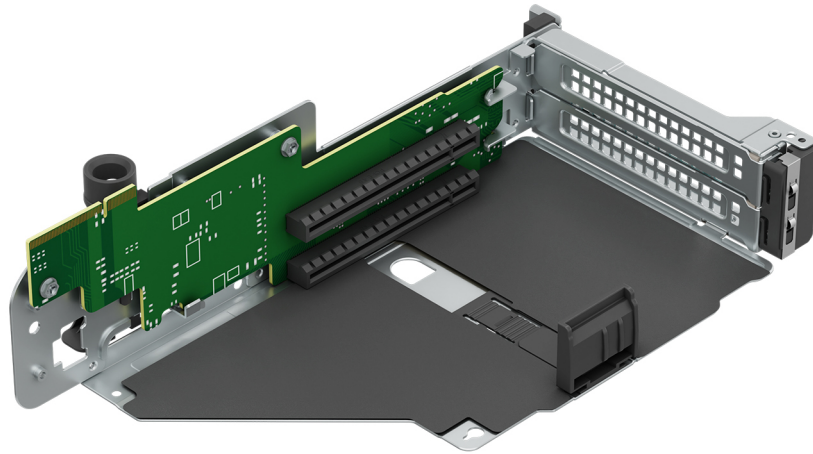

Figure 21. Riser 4B

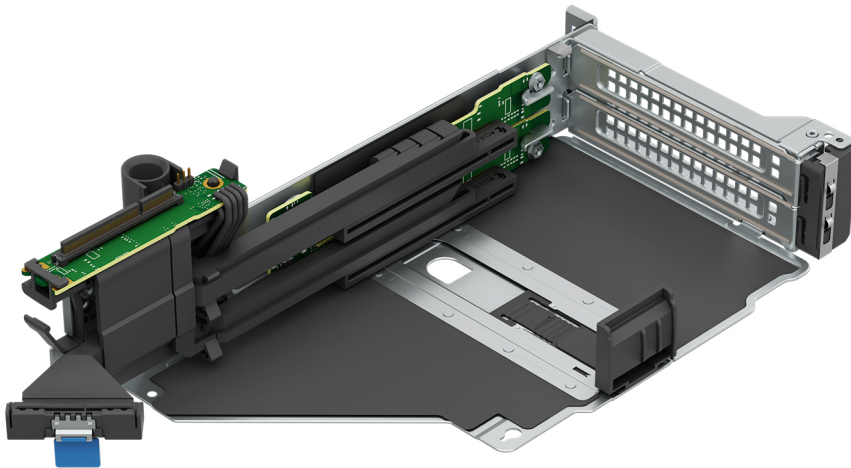

Figure 22. Riser 4C

Table 12. PCIe Riser Configs

Config No.	RSR Configuration	# of CPUs	PERC type supported	Rear Storage Possible
0	R1B+R4B	2 or 4	Front PERC / PERC Adaptor	No
1	R1C+R4C	4	Front PERC / PERC Adaptor	No
2	R1C+R2+R3+R4C	4	Front PERC / PERC Adaptor	No
3	R1C+R2+R4C	4	Front PERC / PERC Adaptor	Yes

Table 13. Riser Config 0: R1B+R4B

Processor					CPU1	CPU2
Configuration	PCIe slot location	Width	Length	Height	R1B	R4B
0: R1B+R4B	PCIe Slot-1	SW	HL	FH	Gen4 x8	-
	PCIe Slot-2	SW	HL	FH	Gen4 x8	-
	PCIe Slot-7	SW	HL	FH	-	Gen4 x8
	PCIe Slot-8	SW	HL	FH	-	Gen4 x8

Table 14. Riser Config 1: R1C+R4C

Processor					CPU1	CPU3	CPU2	CPU4
Configuration	PCIe slot location	Width	Length	Height	R1C		R4C	
1: R1C+R4C	PCIe Slot-1	SW	HL	FH	-	Gen5 x16	-	-
	PCIe Slot-2	SW	HL	FH	Gen5 x16	-	-	-
	PCIe Slot-7	SW	HL	FH	-	-	Gen5 x16	-
	PCIe Slot-8	SW	HL	FH	-	-	-	Gen5 x16

Table 15. Riser Config 2: R1C+R2+R3+R4C

Processor					CPU1	CPU3	CPU1	CPU2	CPU3	CPU4	CPU2	CPU4
Configuration	PCIe slot location	Width	Length	Height	R1C		R2		R3		R4c	
2: R1C+R2+R3+R4C	PCIe Slot-1	SW	HL	FH	-	Gen5 x16	-	-	-	-	-	-
	PCIe Slot-2	SW	HL	FH	Gen5 x16	-	-	-	-	-	-	-
	PCIe Slot-3	SW	HL	LP	-	-	-	Gen5 x16	-	-	-	-
	PCIe Slot-4	SW	HL	FH	-	-	-	-	-	Gen5 x16	-	-
	PCIe Slot-5	SW	HL	FH	-	-	-	-	Gen5 x16	-	-	-
	PCIe Slot-6	SW	HL	LP	-	-	Gen5 x16	-	-	-	-	-
	PCIe Slot-7	SW	HL	FH	-	-	-	-	-	-	Gen5 x16	-
	PCIe Slot-8	SW	HL	FH	-	-	-	-	-	-	-	Gen5 x16

Table 16. Riser Config 3: R1C+R2+R4C

Processor					CPU1	CPU3	CPU1	CPU2	CPU2	CPU4
Configuration	PCIe slot location	Width	Length	Height	R1C		R2		R4C	
3: R1C+R2+R4C	PCIe Slot-1	SW	HL	FH	-	Gen5 x16	-	-	-	-

Table 16. Riser Config 3: R1C+R2+R4C (continued)

Processor					CPU1	CPU3	CPU1	CPU2	CPU2	CPU4
Configu- ration	PCIe slot location	Width	Length	Height	R1C		R2		R4C	
	PCIe Slot-2	SW	HL	FH	Gen5 x16	-	-	-	-	-
	PCIe Slot-3	SW	HL	LP	-	-	Gen5 x16	-	-	-
	PCIe Slot-6	SW	HL	LP	-	-	-	Gen5 x16	-	-
	PCIe Slot-7	SW	HL	FH	-	-	-	-	Gen5 x16	-
	PCIe Slot-8	SW	HL	FH	-	-	-	-	-	Gen5 x16

Power, thermal, and acoustics

PowerEdge servers have an extensive collection of sensors that automatically track thermal activity, which helps regulate temperature thereby reducing server noise and power consumption. The table below lists the tools and technologies Dell offers to lower power consumption and increase energy efficiency.

Topics:

- [Power](#)
- [Thermal](#)
- [Acoustics](#)

Power

Table 17. Power tools and technologies

Feature	Description
Power Supply Units(PSU) portfolio	Dell's PSU portfolio includes intelligent features such as dynamically optimizing efficiency while maintaining availability and redundancy. Find additional information in the Power supply units section.
Tools for right sizing	Enterprise Infrastructure Planning Tool (EIPT) is a tool that can help you determine the most efficient configuration possible. With Dell's EIPT, you can calculate the power consumption of your hardware, power infrastructure, and storage at a given workload. Learn more at Enterprise Infrastructure Planning Tool .
Industry Compliance	Dell's servers are compliant with all relevant industry certifications and guide lines, including 80 PLUS, Climate Savers and ENERGY STAR.
Power monitoring accuracy	PSU power monitoring improvements include: <ul style="list-style-type: none"> • Dell's power monitoring accuracy is currently 1%, whereas the industry standard is 5%. • More accurate reporting of power • Better performance under a power cap
Power capping	Use Dell's systems management to set the power cap limit for your systems to limit the output of a PSU and reduce system power consumption. Dell is the first hardware vendor to leverage AMD's GUARDMI for circuit-breaker fast capping.
Systems Management	iDRAC Enterprise and Datacenter provides server-level management that monitors, reports and controls power consumption at the processor, memory and system level. Dell OpenManage Power Center delivers group power management at the rack, row, and data center level for servers, power distribution units, and uninterruptible power supplies.
Active power management	AMD's GUARDMI is an embedded technology that provides individual server-level power reporting and power limiting functionality. Dell offers a complete power management solution comprised of AMD's GUARDMI accessed through Dell iDRAC9 Datacenter and OpenManage Power Center that allows policy-based management of power and thermal at the individual server, rack, and data center level. Hot spare reduces power consumption of redundant power supplies. Thermal control off a speed optimizes the thermal settings for your environment to reduce fan consumption and lower system power consumption. Idle power enables Dell servers to run as efficiently when idle as when at full workload.
Fresh Air cooling	See ASHRAE A3/A4 Thermal Restriction.

Table 17. Power tools and technologies (continued)

Feature	Description
Rack infrastructure	Dell offers some of the industry's highest-efficiency power infrastructure solutions, including: <ul style="list-style-type: none"> • Power distribution units (PDUs) • Uninterruptible power supplies (UPSs) • Energy Smart containment rack enclosures Find additional information at: Data Center Power and Cooling Solutions .

Power Supply Units

Energy Smart power supplies have intelligent features, such as the ability to dynamically optimize efficiency while maintaining availability and redundancy. Also featured are enhanced power-consumption reduction technologies, such as high-efficiency power conversion and advanced thermal-management techniques, and embedded power-management features, including high-accuracy power monitoring. The table below shows the power supply unit options that are available for the R860.

Table 18. Power Supply Unit Options

Wattage	Frequency	Voltage/Current	Class	Heat dissipation
1100 W mixed mode	50/60 Hz	100–240 Vac/12—3.6 A	Titanium	4100 BTU/hr
	N/A	240 Vdc/5.2 A	N/A	4100 BTU/hr
1400 W mixed mode	50/60 Hz	100–240 Vac/12—8 A	Platinum	5250 BTU/hr
	N/A	240 Vdc/6.6 A	N/A	5250 BTU/hr
1800 W mixed mode	50/60 Hz	200–240 Vac/10 A	Titanium	6750 BTU/hr
	N/A	240 Vdc/8.2 A	N/A	6750 BTU/hr
2400 W mixed mode	50/60 Hz	100–240 Vac/ 16—13.5 A	Platinum	9000 BTU/hr
	N/A	240 Vdc/11.2 A	N/A	9000 BTU/hr
2800 W mixed mode	50/60 Hz	200–240 Vac/15.6 A	Titanium	10,500 BTU/hr
	N/A	240 Vdc/13.6 A	N/A	10,500 BTU/hr

NOTE: If a system with AC 2400 W PSUs operates at low line 100-120 Vac, and then the power rating per PSU is degraded to 1400 W.

NOTE: If a system with AC 1400 W or 1100 W PSUs operates at low line 100-120 Vac, and then the power rating per PSU is degraded to 1050 W.



Figure 23. PSU power cords

Table 19. PSU power cords

Form factor	Output	Power cord
Redundant 60 mm	1100 W AC	C13
	1400 W AC	C13
	1800 W AC	C15

Table 19. PSU power cords (continued)

Form factor	Output	Power cord
Redundant 86 mm	2400 W AC	C19
	2800 W AC	C21

NOTE: C19 power cord combined with C20 to C21 jumper power cord can be used to adapt 2800 W PSU.

NOTE: C13 power cord combined with C14 to C15 jumper power cord can be used to adapt 1800 W PSU.

Thermal

PowerEdge servers have an extensive collection of sensors that automatically track thermal activity, which helps regulate temperature thereby reducing server noise and power consumption.

Thermal design

Thermal management of the platform helps deliver high performance with the right amount of cooling to components, while maintaining the lowest fan speeds possible. This is done across a wide range of ambient temperatures from 10°C to 35°C (50°F to 95°F) and to extended ambient temperature ranges.

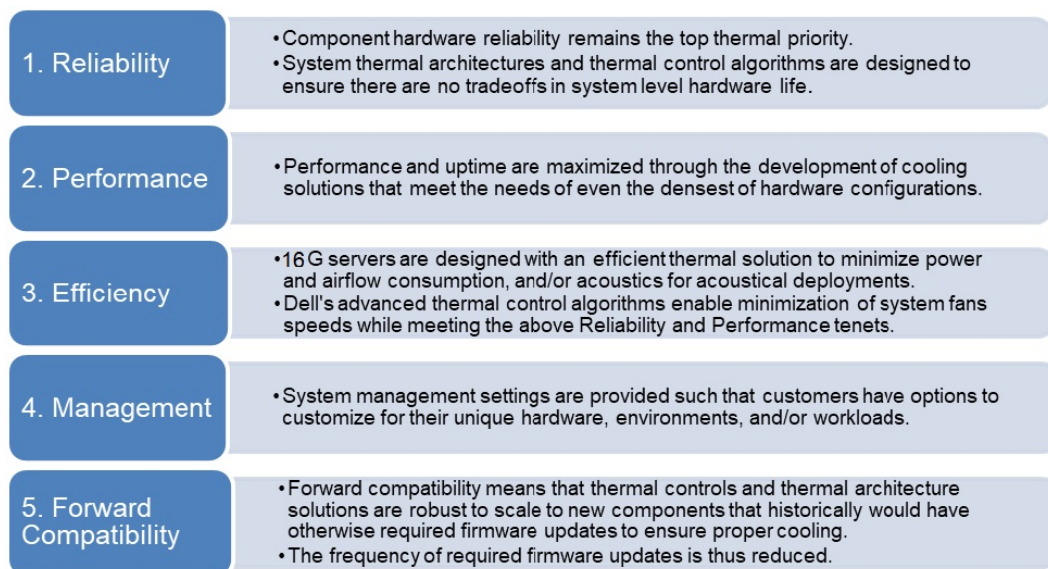

Figure 24. Thermal design characteristics

The thermal design of the PowerEdge R860 reflects the following:

- Optimized thermal design: The system layout is architected for optimum thermal design.
- System component placement and layout are designed to provide maximum airflow coverage to critical components with minimum expense of fan power.
- Comprehensive thermal management: The thermal control system regulates the fan speed based on several different responses from all system-component temperature sensors, as well as inventory for system configurations. Temperature monitoring includes components such as processors, DIMMs, chipset, the inlet air ambient, hard disk drives, and OCP.
- Open and closed loop thermal fan speed control: Open loop thermal control uses system configuration to determine fan speed based on inlet air ambient temperature. Closed loop thermal control method uses feedback temperatures to dynamically determine proper fan speeds.
- User-configurable settings: With the understanding and realization that every customer has unique set of circumstances or expectations from the system, in this generation of servers, we have introduced limited user-configurable settings residing in the iDRAC BIOS setup screen. For more information, see the Dell PowerEdge R860 Installation and Service Manual at [PowerEdge Manuals](#) and "Advanced Thermal Control: Optimizing across Environments and Power Goals" on Dell.com.

- Cooling redundancy: The R860 allows N+1 fan redundancy, allowing continuous operation with one fan failure in the system.
- Environmental Specifications: The optimized thermal management makes the R860 reliable under a wide range of operating environments.

Acoustics

Acoustical performance

Dell PowerEdge R860 is a rack-mount server appropriate for an office to that of data center environment. Although the R860 is designed for use in data centers, some users may prefer to use it in a quieter setting. However in most cases, the idle air mover speed of the system cannot be lowered without changing the configuration of the system, and in some cases, even a configuration change may not reduce idle air mover speeds.

Table 20. Acoustical Configurations of R860

Configuration	Quietest	HCI	Data Management	Machine Learning
CPU TDP	195 W	250 W	250 W	350 W
CPU Quantity	4	4	4	4
RDIMM Memory	16 GB DDR5	64 GB DDR5	64 GB DDR5	64 GB DDR5
Memory Quantity	4	24	48	64
Backplane Type	2.5-inch x 24 BP	2.5-inch x 24 BP	2.5-inch x 8 BP	2.5-inch x 24 BP
HDD Type	SATA 2.5-inch 600 GB	SATA 2.5-inch 600 GB	SATA 2.5-inch 1.2 TB	SATA 2.5-inch 1.8 TB
HDD Quantity	24	24	24	24
M.2 Drives	NVMe 480 GB	NVMe 480 GB	NVMe 480 GB	NVMe 480 GB
M.2 Quantity	1	1	1	1
PSU Type	2400 W	2800 W	2400 W	2800 W
PSU Quantity	2	2	2	2
OCP	X	OCP3 10 GB 2-port	OCP3 10 GB 2-port	OCP3 10 GB 2-port
PCI 1	X	X	X	X
PCI 2	X	X	X	X
PCI 3	X	X	X	X
PCI 4	X	X	X	X
PCI 5	X	X	X	X
PCI 6	X	X	X	X
PCI 7	X	X	X	X
PCI 8	X	X	X	X
PCI 9	X	X	X	X
PERC	Front HBA355i	Front HBA355i	Front HBA355i	Front HBA355i

Table 21. Acoustical experience of R860 configurations

Configuration		Quietest	HCI	Data Management	Machine Learning
Acoustical Performance: Idle/ Operating @ 25°C Ambient					
L _{wA,m} (B)	Idle ⁽⁴⁾	5.4	5.7	5.6	5.8
	Operating/Customer usage operating ⁽⁵⁾⁽⁶⁾	5.8	7.0	6.6	7.1
K _v (B)	Idle ⁽⁴⁾	0.4	0.4	0.4	0.4
	Operating/Customer usage operating ⁽⁵⁾⁽⁶⁾	0.4	0.4	0.4	0.4
L _{pA,m} (dB)	Idle ⁽⁴⁾	38	42	40	43
	Operating/Customer usage operating ⁽⁵⁾⁽⁶⁾	45	55	50	54
Prominent discrete tones ⁽³⁾		Prominence ratio < 15 dB			
Acoustical Performance: Idle @ 28°C Ambient					
L _{wA,m} ⁽¹⁾ (B)		5.7	6.2	6.3	6.2
K _v (B)		0.4	0.4	0.4	0.4
L _{pA,m} ⁽²⁾ (dB)		41	46	46	45
Acoustical Performance: Max. loading @ 35°C Ambient					Mx. Loading @ 30°C Ambient
L _{wA,m} ⁽¹⁾ (B)		7.6	8.7	8.6	8.7
K _v (B)		0.4	0.4	0.4	0.4
L _{pA,m} ⁽²⁾ (dB)		61	71	69	71

⁽¹⁾L_{wA,m}: The declared mean A-weighted sound power level (L_{wA}) is calculated per section 5.2 of ISO 9296 (2017) with data collected using the methods that are described in ISO 7779 (2010). Engineering data presented here may not be fully compliant with ISO 7779 declaration requirement.

⁽²⁾L_{pA,m}: The declared mean A-weighted emission sound pressure level is at the bystander position per section 5.3 of ISO 9296 (2017) and measured using methods that are described in ISO 7779 (2010). The system is placed in a 24U rack enclosure, 75 cm above a reflective floor. Engineering data presented here may not be fully compliant with ISO 7779 declaration requirement.

⁽³⁾Prominent tones: Criteria of Annex D of ECMA-74 and Prominence Ratio method of ECMA-418 are followed to determine if discrete tones are prominent and to report them, if so.

⁽⁴⁾Idle mode: The steady-state condition in which the server is energized but not operating any intended function.

⁽⁵⁾Operating mode: The maximum of the steady state acoustical output at 50% of CPU TDP or active storage drives for the respective sections of Annex C of ECMA-74.

⁽⁶⁾ Customer Usage Operating mode: The operating mode is represented by the maximum of the steady state acoustical output at 10 - 50% of CPU TDP, 40% of Memory, and 10% IOPs load as the components showed in the above configurations.

Rack, rails, and cable management

Topics:

- [Rails and cable management information](#)

Rails and cable management information

The rail offerings for the PowerEdge R860 consist of two general types: sliding and static. The cable management offerings consist of an optional cable management arm (CMA) and an optional strain relief bar (SRB).

See the *Dell Enterprise Systems Rail Sizing and Rack Compatibility Matrix* available at [Rack Compatibility Matrix](#) for information regarding:

- Specific details about rail types.
- Rail adjustability ranges for various rack mounting flange types
- Rail depth with and without cable management accessories
- Rack types that are supported for various rack mounting flange types

Key factors governing proper rail selection include the following:

- Spacing between the front and rear mounting flanges of the rack
- Type and location of any equipment that is mounted in the back of the rack such as power distribution units (PDUs)
- Overall depth of the rack

Sliding rails features summary

The sliding rails allow the system to be fully extended out of the rack for service. There is one type of sliding rail available: Stab-in/Drop-in sliding rails. The sliding rails are available with or without the optional cable management arm (CMA) or strain relief bar (SRB).

B24 Stab-in/Drop-in sliding rails for 4-post racks

- Supports drop-in or stab-in installation of the chassis to the rails.
- Support for tool-less installation in 19" EIA-310-E compliant square, un-threaded round hole racks including all generations of the Dell racks. Also supports tool-less installation in threaded round hole 4-post racks.
- Support for tool-less installation in Dell Titan or Titan-D racks
- Support full extension of the system out of the rack to allow serviceability of key internal components.
- Support for an optional cable management arm (CMA).
- Support for optional strain relief bar (SRB).

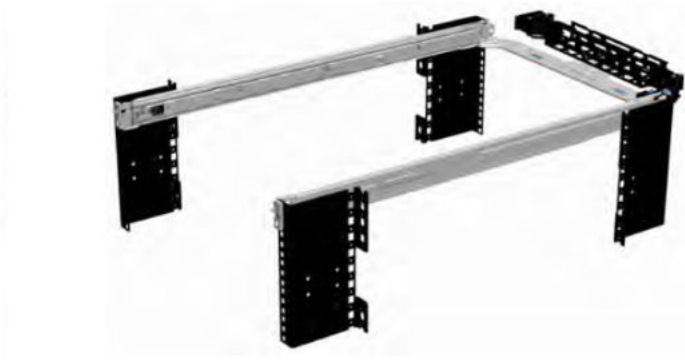

Figure 25. Sliding rails with optional CMA



Figure 26. Sliding rails with optional SRB

B19 static rails summary

The static rails offer a greater adjustability range and a smaller overall mounting footprint than the sliding rails because of their reduced complexity and lack of need for CMA support. The static rails support a wider variety of racks than the sliding rails. However, they do not support serviceability in the rack and are thus not compatible with the CMA. The static rails are also not compatible with SRB.

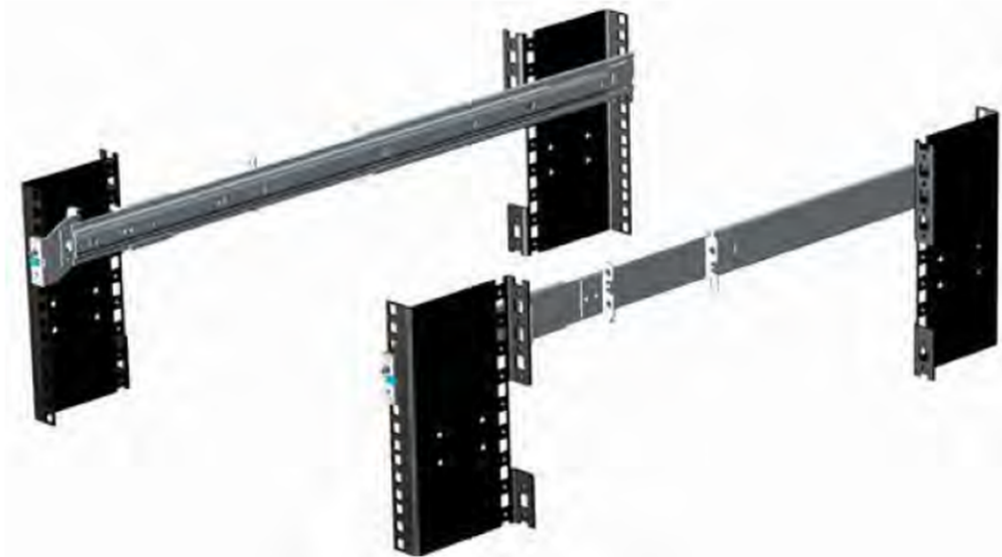

Figure 27. Static rails

Static rails features summary

Static rails for 4-post & 2-post racks:

- Supports stab-in installation of the chassis to the rails.
- Support tool-less installation in 19" EIA-310-E compliant square or un-threaded round hole 4-post racks including all generations of Dell racks.
- Support tooled installation in 19" EIA-310-E compliant threaded hole 4-post and 2-post racks.
- Support for tooled installation in Dell Titan or Titan-D rack.

i NOTE:

- Screws are not included with the static rail kit since racks are offered with various thread types. The screws are provided for mounting static rails in racks with threaded mounting flanges.
- Screw head diameter should be 10 mm or less.

2-Post racks installation

If installing to 2-Post (Telco) racks, the ReadyRails static rails (B19) must be used. Sliding rails support mounting in 4-post racks only.



Figure 28. Static rails in 2-post center mount configuration

Installation in the Dell Titan or Titan-D racks

For tool-less installation in Titan or Titan-D racks, the Stab-in/Drop-in Sliding rails (B24) must be used. This rail collapses down sufficiently to fit in the rack with mounting flanges that are spaced about 24 inches apart from front to back. The Stab-in/Drop-in Sliding rail allows bezels of the servers and storage systems to be aligned when installed in these racks. For tooled installation, Stab-in Static rails (B19) must be used for bezel alignment with Storage systems.

Cable management arm (CMA)

The optional cable management arm (CMA) organizes and secures the cords and cables exiting the back of the systems. It unfolds to allow the systems to extend out of the rack without having to detach the cables. Some key features of the CMA include:

- Large U-shaped baskets to support dense cable loads.
- Open vent pattern for optimal airflow.
- Ability to mount on either side by swinging the spring-loaded brackets from one side to the other.
- Utilizes hook-and-loop straps rather than plastic tie wraps to eliminate the risk of cable damage during cycling.
- Includes a low-profile fixed tray to both support and retain the CMA in its fully closed position.
- Both the CMA and the tray mount without the use of tools by simple and intuitive snap-in designs.

The CMA can be mounted to either side of the sliding rails without the use of tools or the need for conversion. For systems with one power supply unit (PSU), it is recommended to mount on the side opposite to that of the power supply to allow easier access to it and the rear drives (if applicable) for service or replacement.

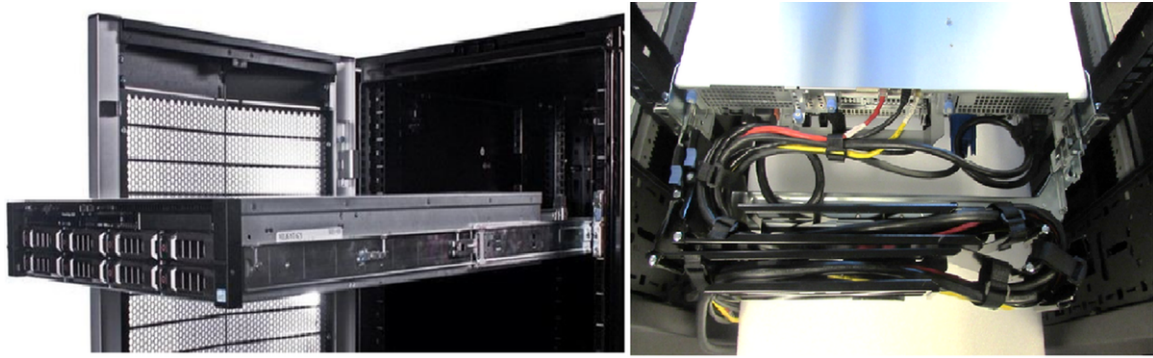

Figure 29. Sliding rails with CMA cabling

Strain Relief Bar (SRB)

The optional strain relief bar (SRB) for the PowerEdge R860 organizes and supports cable connections at the rear end of the server to avoid damage from bending.

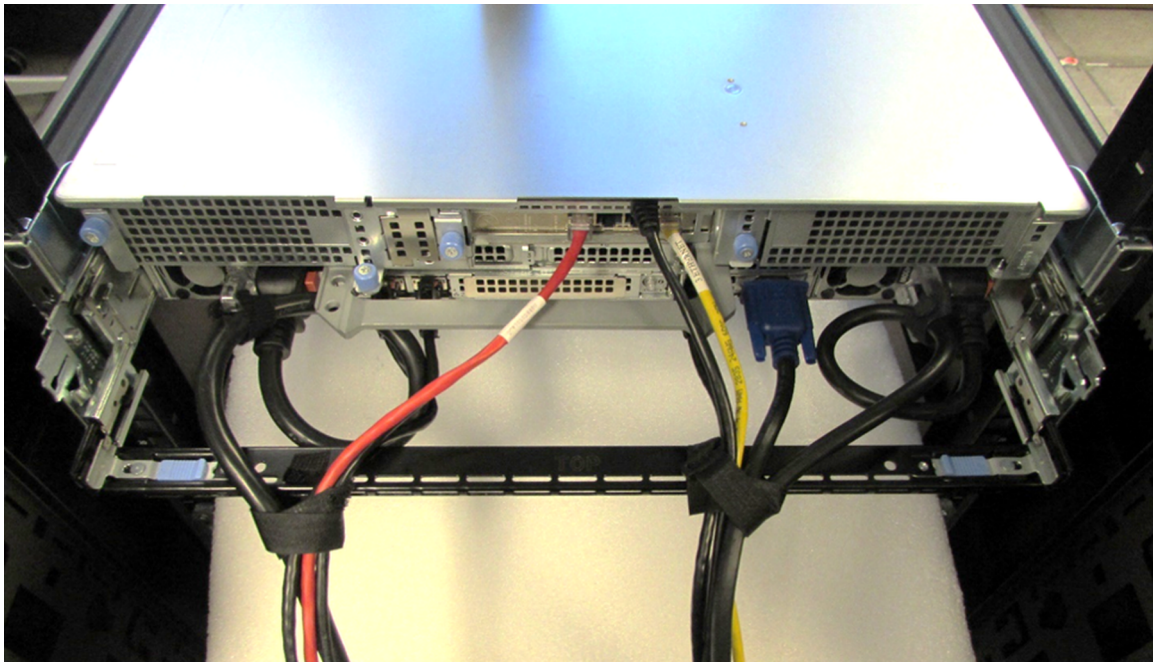

Figure 30. Cabled strain relief bar

- Tool-less attachment to the rails
- Two depth positions to accommodate various cable loads and rack depths
- Supports cable loads and controls stresses on server connectors
- Cables can be separated into discrete purpose-specific bundles

Rack Installation

Drop-in design means that the system is installed vertically into the rails by inserting the standoffs on the sides of the system into the J-slots in the inner rail members with the rails in the fully extended position. The recommended method of installation is to first insert the rear standoffs on the system into the rear J-slots on the rails to free up a hand and then rotate the system down into the remaining J-slots while using the free hand to hold the rail against the side of the system.

Installing system into the rack (option A: Drop-In)

1. Pull the inner rails out of the rack until they lock into place.

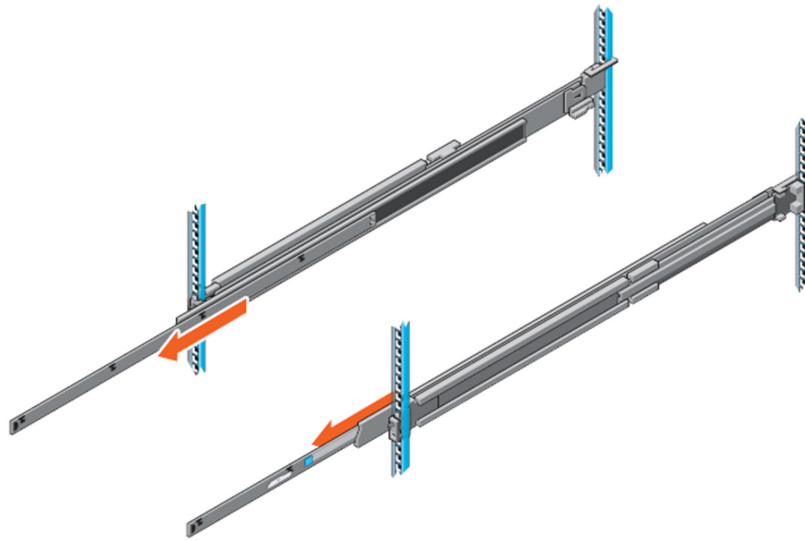

Figure 31. Pull out inner rail

2. Locate the rear rail standoff on each side of the system and lower them into the rear J-slots on the slide assemblies.
3. Rotate the system downward until all the rail standoffs are seated in the J-slots.

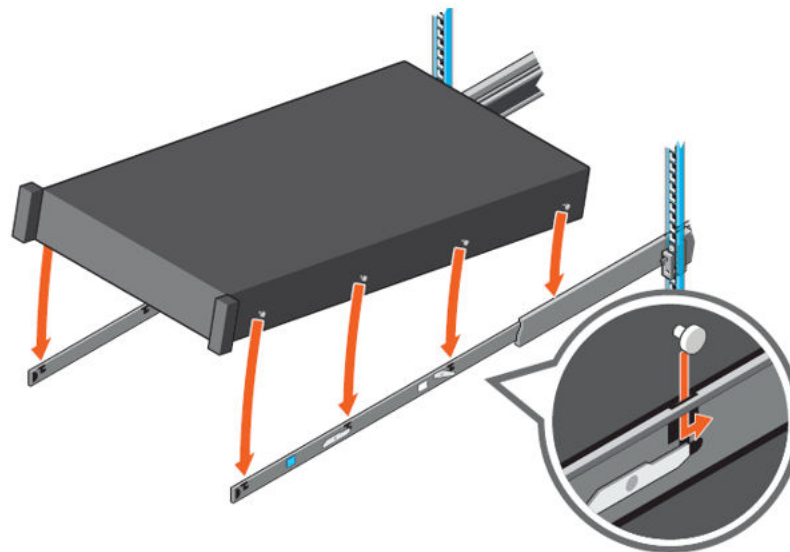

Figure 32. Rail standoffs seated in J-slots

4. Push the system inward until the lock levers click into place.
5. Pull the blue side release lock tabs forward or backward on both rails and slide the system into the rack until the system is in the rack.

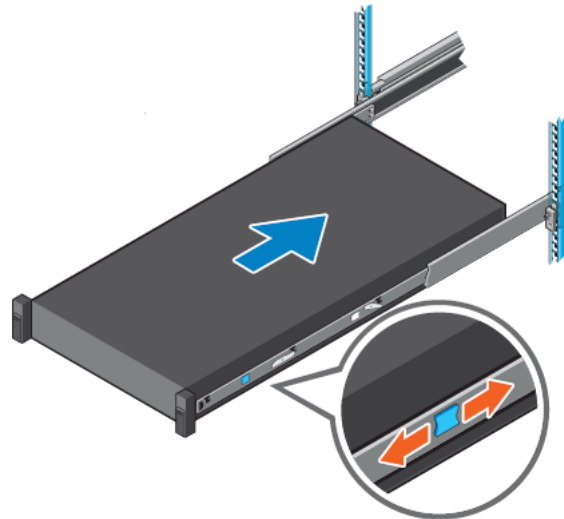

Figure 33. Slide system into the rack

Installing the system into the rack (option B: Stab-In)

1. Pull the intermediate rails out of the rack until they lock into place.
2. Release the inner rail lock by pulling forward on the white tabs and sliding the inner rail out of the intermediate rails.

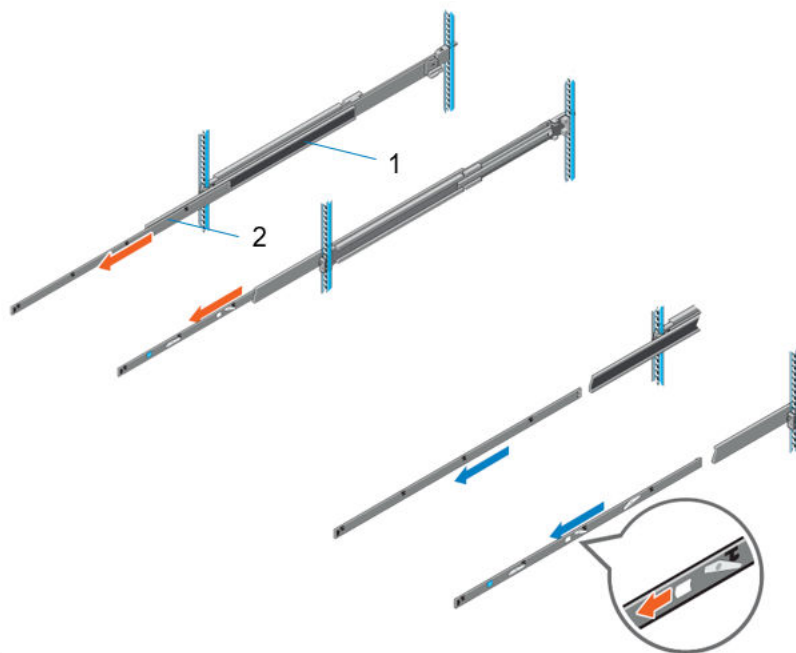

Figure 34. Pull out the intermediate rail

Table 22. Rail component label

Number	Component
1	Intermediate rail
2	Inner rail

3. Attach the inner rails to the sides of the system by aligning the J-slots on the rail with the standoffs on the system and sliding forward on the system until they lock into place.

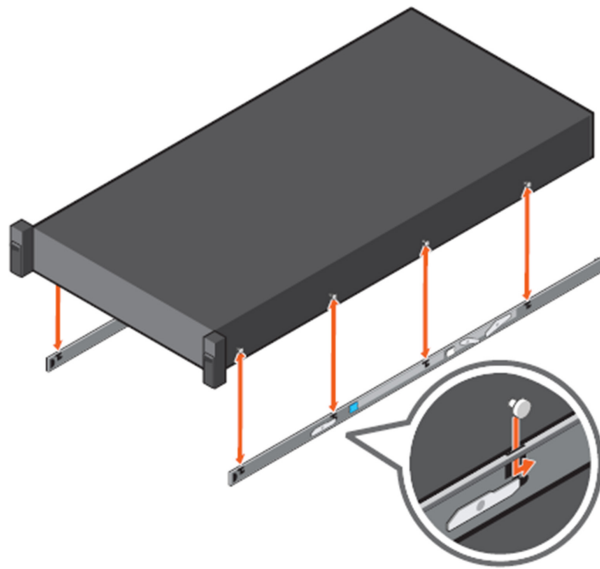

Figure 35. Attach the inner rails to the system

4. With the intermediate rails extended, install the system into the extended rails.

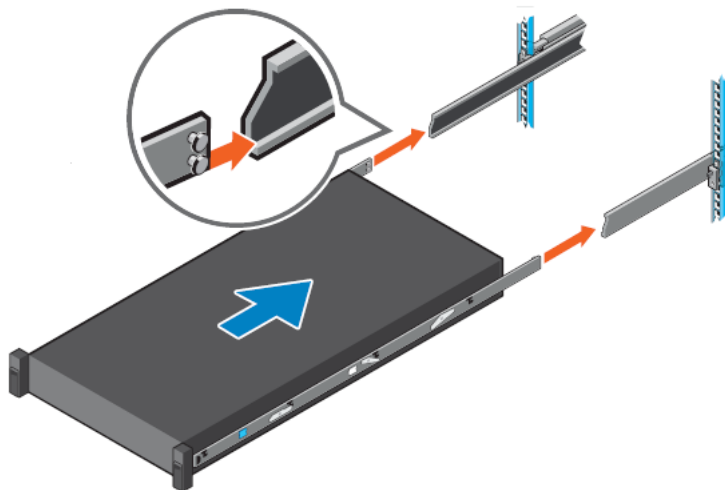

Figure 36. Install system into the extended rails

5. Pull blue slide release lock tabs forward or backward on both rails, and slide the system into the rack.

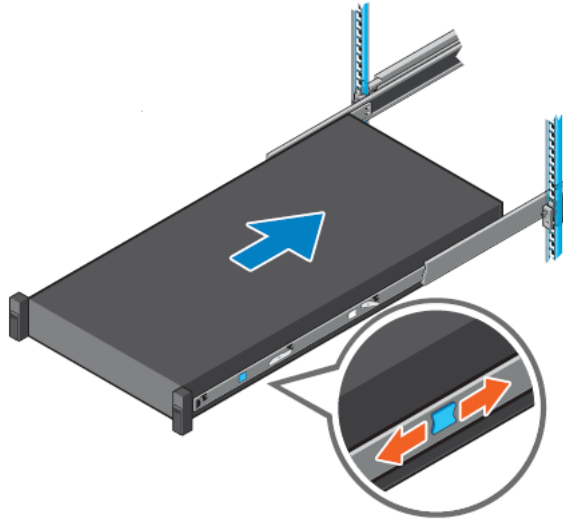

Figure 37. Slide system into the rack

Operating Systems and Virtualization

Topics:

- [Supported operating systems](#)

Supported operating systems

The PowerEdge R860 system supports the following operating systems:

- Canonical Ubuntu Server LTS
- Microsoft Windows Server with Hyper-V
- Red Hat Enterprise Linux
- SUSE Linux Enterprise Server
- VMware ESXi
- Citrix XenServer

For more information, go to [Operating System Manuals](#).

Dell OpenManage Systems Management

Dell delivers management solutions that help IT administrators effectively deploy, update, monitor, and manage IT assets. OpenManage solutions and tools enable you to quickly respond to problems by helping them to manage Dell servers efficiently; in physical, virtual, local, and remote environments; all without the need to install an agent in the operating system.

The OpenManage portfolio includes:

- Innovative embedded management tool - integrated Dell Remote Access Controller (iDRAC)
- Consoles - OpenManage Enterprise
- Extensible with plug-ins - OpenManage Power Manager
- Update tools - Repository Manager

Dell has developed comprehensive systems management solutions that are based on open standards and has integrated with management consoles from partners such as Microsoft and VMware, allowing advanced management of Dell servers. Dell management capabilities extend to offerings from the industry's top systems management vendors and frameworks such as Ansible, Splunk, and ServiceNow. OpenManage tools automate the full span of server life cycle management activities along with powerful RESTful APIs to script or integrate with your choice of frameworks.

For more information about the entire OpenManage portfolio, see:

- The latest [Dell Systems Management Overview Guide](#).

Topics:

- [Integrated Dell Remote Access Controller \(iDRAC\)](#)
- [Systems Management software support matrix](#)

Integrated Dell Remote Access Controller (iDRAC)

iDRAC9 delivers advanced, agent-free, local and remote server administration. Embedded in every PowerEdge server, iDRAC9 provides a secure means to automate a multitude of common management tasks. Because iDRAC is embedded within every PowerEdge server, there is no additional software to install; just plug in power and network cables, and iDRAC is ready to go. Even before installing an operating system (operating system) or hypervisor, IT administrators have a complete set of server management features at their fingertips.

With iDRAC9 in-place across the Dell PowerEdge portfolio, the same IT administration techniques and tools can be applied throughout. This consistent management platform allows easy scaling of PowerEdge servers as an organization's infrastructure grows. Customers can use the iDRAC RESTful API for the latest in scalable administration methods of PowerEdge servers. With this API, iDRAC enables support for the Redfish standard and enhances it with Dell extensions to optimize at-scale management of PowerEdge servers. By having iDRAC at the core, the entire OpenManage portfolio of Systems Management tools allows every customer to tailor an effective, affordable solution for any size environment.

Zero Touch Provisioning (ZTP) is embedded in iDRAC. ZTP - Zero Touch Provisioning is Intelligent Automation Dell's agent-free management puts IT administrators in control. Once a PowerEdge server is connected to power and networking, that system can be monitored and fully managed, whether you're standing in front of the server or remotely over a network. In fact, with no need for software agents, an IT administrator can: · Monitor · Manage · Update · Troubleshoot and remediate Dell servers With features like zero-touch deployment and provisioning, iDRAC Group Manager, and System Lockdown, iDRAC9 is purpose-built to make server administration quick and easy. For those customers whose existing management platform utilizes in-band management, Dell does provide iDRAC Service Module, a lightweight service that can interact with both iDRAC9 and the host operating system to support legacy management platforms.

When ordered with DHCP enabled from the factory, PowerEdge servers can be automatically configured when they are initially powered up and connected to your network. This process uses profile-based configurations that ensure each server is configured per your specifications. This feature requires an iDRAC Enterprise license.

iDRAC9 offers following license tiers:

Table 23. iDRAC9 license tiers

License	Description
iDRAC9 Basic	<ul style="list-style-type: none"> Available only on 100-500 series rack/tower Basic instrumentation with iDRAC web UI For cost conscious customers that see limited value in management
iDRAC9 Express	<ul style="list-style-type: none"> Default on 600+ series rack/tower, modular, and XR series Includes all features of Basic Expanded remote management and server life-cycle features
iDRAC9 Enterprise	<ul style="list-style-type: none"> Available as an upsell on all servers Includes all features of Basic and Express. Includes key features such as virtual console, AD/LDAP support, and more Remote presence features with advanced, Enterprise-class, management capabilities
iDRAC9 Datacenter	<ul style="list-style-type: none"> Available as an upsell on all servers Includes all features of Basic, Express, and Enterprise. Includes key features such as telemetry streaming, Thermal Manage, automated certificate management, and more Extended remote insight into server details, focused on high end server options, granular power, and thermal management

For a full list of iDRAC features by license tier, see [Integrated Dell Remote Access Controller 9 User's Guide](#) at [Dell.com](#).

For more details on iDRAC9 including white papers and videos, see:

- [Support for Integrated Dell Remote Access Controller 9 \(iDRAC9\)](#) on the [Knowledge Base](#) page at [Dell.com](#)

Systems Management software support matrix

Table 24. Systems Management software support matrix

Categories	Features	PE mainstream
Embedded Management and In-band Services	iDRAC9 (Express, Enterprise, and Datacenter licenses)	Supported
	OpenManage Mobile	Supported
	OM Server Administrator (OMSA)	Supported
	iDRAC Service Module (iSM)	Supported
	Driver Pack	Supported
Change Management	Update Tools (Repository Manager, DSU, Catalogs)	Supported
	Server Update Utility	Supported
	Lifecycle Controller Driver Pack	Supported
	Bootable ISO	Supported
Console and Plug-ins	OpenManage Enterprise	Supported
	Power Manager Plug-in	Supported
	Update Manager Plug-in	Supported
	SupportAssist Plug-in	Supported
	CloudIQ	Supported
Integrations and connections	OM Integration with VMware Vcenter/vROps	Supported
	OM Integration with Microsoft System Center (OMIMSC)	Supported
	Integrations with Microsoft System Center and Windows Admin Center (WAC)	Supported

Table 24. Systems Management software support matrix (continued)

Categories	Features	PE mainstream
	ServiceNow	Supported
	Ansible	Supported
	Third-party Connectors (Nagios, Tivoli, Microfocus)	Supported
Security	Secure Enterprise Key Management	Supported
	Secure Component Verification	Supported
Standard operating system	Red Hat Enterprise Linux, SUSE, Windows Server 2021 Ubuntu, CentOS	Supported (Tier-1)

Appendix D: Service and support

Topics:

- [Default support levels](#)
- [Other services and support information](#)

Default support levels

This system offers 3 years Dell ProSupport Next Business Day (NBD), including 24x7 phone support and NBD parts and labor support.

Default deployment levels

This system is defaulted to the ProDeploy Dell Server R860 which includes onsite hardware installation and software configuration. C-series sleds require a deploy service on each sled purchased. Installation of the enclosure is included at no additional charges. Optionally, the customer may choose any of the factory or field deployment offers listed below.

Other services and support information

Dell Technologies Services include a wide, customizable range of service options to simplify the assessment, design, implementation, management and maintenance of IT environments and to help transition from platform to platform.

Depending on the current business requirements and correct level of service for customers, we provide factory, onsite, remote, modular, and specialized services that fit the customer requirements and budget. We will help with a little or a lot, based on the customer's choice, and provide access to our global resources.

ProDeploy Infrastructure Suite

ProDeploy Infrastructure Suite provides various deployment offerings that satisfy a customer's unique needs. It is made up of 5 offers: ProDeploy Configuration Services, ProDeploy Rack Integration Services, Basic Deployment, ProDeploy, and ProDeploy Plus.

ProDeploy Infrastructure Suite

Versatile choices for accelerated deployments

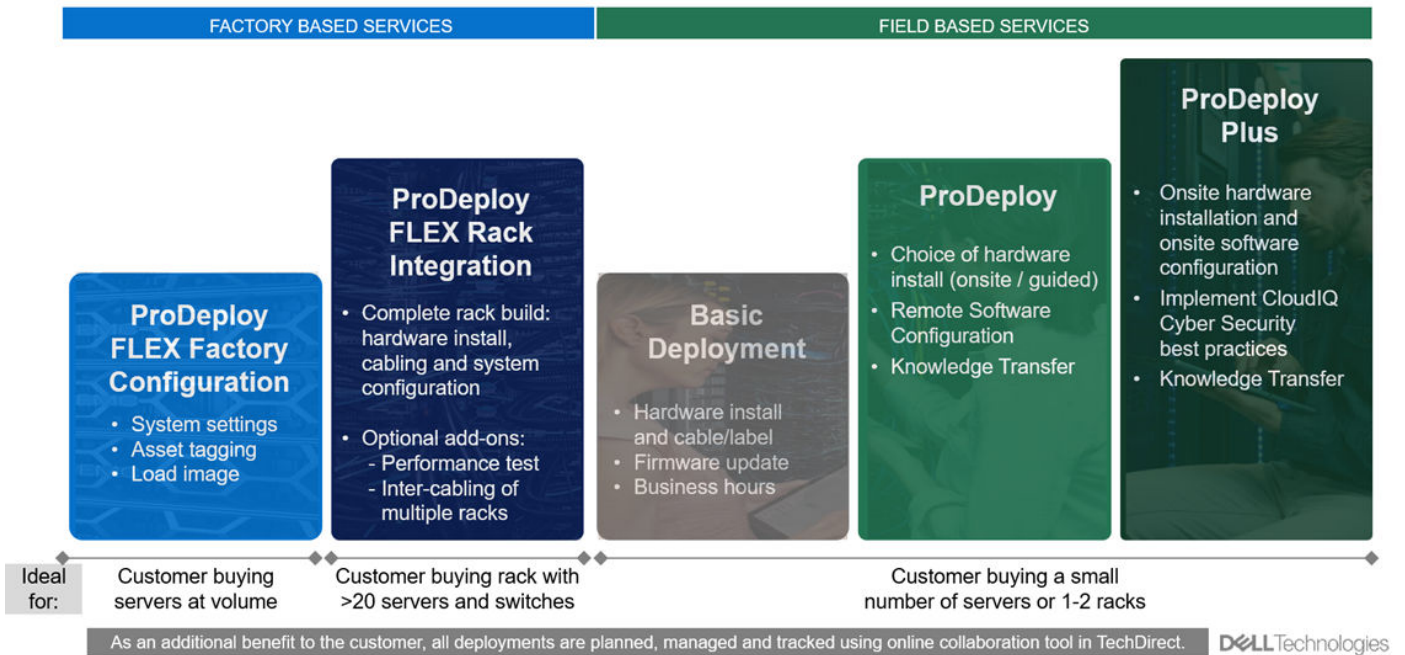

Figure 38. ProDeploy Infrastructure Suite

Factory-based Services

The new Factory Services consist of two tiers of deployment that happen prior to shipping to the Customer's site.

ProDeploy FLEX Factory Configuration

Ideal for Customers buying servers in volume and seeking pre-configuration prior to shipping such as: custom image, system settings, and asset tagging so it arrives ready to use out of the box. Furthermore, servers are packaged and bundled to meet specific shipping and distribution requirements for each customer location to facilitate the rollout process. Once the server is onsite, Dell can install and configure the server to the environment using any of the field-based deployment services outlined in the next section.

ProDeploy FLEX Rack Integration

Ideal for customers seeking to build out fully integrated racks prior to shipping. These rack builds include hardware install, cabling, and full system configuration. You can also add-on a factory stress test and optional on-site final rack configuration to complete the rack installation.

- STANDARD SKUs for Rack Integration is available in USA only and requires:
 - 20 or more devices (R and C series servers, VxRail, and all Dell or non-Dell switches).
 - Shipping to contiguous USA.
- USE CUSTOM QUOTE for Rack Integration scenarios that require:
 - Shipment to any country or region outside USA or shipping outside contiguous USA
 - Shipping to multiple locations
 - Racks containing fewer than 20 servers
 - Any rack that includes Storage.

ProDeploy Flex | Modular deployment (built in factory, onsite or remote)

Pre -deployment	Single point of contact for project management	●
	Expanded end-to-end project management	Selectable
	Site readiness review and implementation planning	●
Deployment	Deployment service hours	24/7
	Hardware installation options ¹	Onsite, factory ^{2,5} or remote ³
	System software installation and configuration options ¹	Onsite, factory ^{2,5} or remote ³
	Multivendor networking deployment ⁴	Onsite, factory ^{2,5} or remote ³
	Onsite Deployment in remote locations	Selectable
	Onsite Deployment in challenging environments	Selectable
	Onsite Deployment with special site-based protocols or requirements	Selectable
	Install connectivity software based on Secure Connect Gateway technology	●
	Dell NativeEdge Orchestrator deployment	Selectable
	Configure 3 rd party software applications and workloads ⁴	Selectable
Post -deployment	Deployment verification, documentation, and knowledge transfer	●
	Configuration data transfer to Dell support	●
Online collaboration	Online collaborative environment - Planning, managing and tracking delivery process	●

¹ Hardware and Software delivery methods can be independently chosen; selecting Rack integration for software requires hardware Rack integration to also be selected.

² Factory Rack Integration for server and VxRail; includes associated Dell network switches; final onsite rack installation available.

³ Remote hardware option includes project specific instructions, documentation and live expert guidance for hardware installation.

⁴ Select 3rd party multivendor networking and software applications.

⁵ Pair with Field Onsite Hardware service for final installation.

Figure 39. ProDeploy Flex modular services

Field-based services

- **ProDeploy Plus:**

Elevate Infrastructure deployments with our most complete service from planning through onsite hardware installation and software configuration including the implementation of cybersecurity best practices. ProDeploy Plus provides the skill and scale that is needed to successfully perform demanding deployments in today's complex IT environments. The deployment starts with a site readiness review and implementation plan. Certified deployment experts perform the software configuration to include setup of leading operating systems and hypervisors. Dell will also configure PowerEdge software tools to include iDRAC and OpenManage system utilities and support AIOps platforms: MyService360, TechDirect, and CloudIQ. Unique to ProDeploy Plus, the cybersecurity implementation helps customers understand potential security risks and make recommendations for reducing product attack surfaces. The system is tested, validated prior to completion. The customer will also receive full project documentation and knowledge transfer to complete the process.

- **ProDeploy:**

ProDeploy provides remote software configuration and choice of hardware installation (onsite or guided). ProDeploy is great for customers who are price sensitive or willing to participate in some portion of the deployment to include providing remote access to their network. The ProDeploy remote software implementation includes everything that is mentioned in ProDeploy Plus except it does not include the added value, cybersecurity implementation and best practices.

ProDeploy Infrastructure Suite | Field services

		Basic Deployment	ProDeploy	ProDeploy Plus
Pre-deployment	Single point of contact for project management	-	●	In region
	Site readiness review and implementation planning	-	●	●
Deployment	Deployment service hours	Business hours	24/7	24/7
	Hardware installation options	Onsite	Onsite or guided ¹	Onsite
	System software installation and configuration options	-	Remote	Onsite
	Install connectivity software based on Secure Connect Gateway technology ²	-	●	●
	Implement CyberSecurity best practices and policies in APEX AIOps Infrastructure Observability	-	-	●
Post-deployment	Deployment verification, documentation and knowledge transfer	-	●	●
	Configuration data transfer to Dell technical support	-	●	●
Online collaboration	Online collaborative platform in TechDirect for planning, managing and tracking delivery	-	●	●

¹ Choose from onsite hardware installation or a guided option including project specific instructions, documentation and live expert guidance
² Post deployment use for intelligent, automated support & insights

Figure 40. ProDeploy Infrastructure Suite - Field services

Dell custom deployment Services

Dell custom rack integration and other Dell configuration services help customers save time by providing systems that are racked, cabled, tested, and ready to be integrated into the data center. Dell support preconfigure RAID, BIOS and iDRAC settings, install system images, and even install third-party hardware and software.

For more information, see [Server Configuration Services](#).

Dell Residency Services

Residency Services help customers transition to new capabilities quickly with the assistance of onsite or remote Dell experts whose priorities and time they control.

Residency experts can provide post implementation management and knowledge transfer that is related to a new technology acquisition or day-to-day operational management of the IT infrastructure.

Dell Data Migration Services

Protect business and data of the customer with our single point of contact to manage data migration projects.

A customer project manager works with our experienced team of experts to create a plan using industry-leading tools and proven processes that are based on global best practices to migrate existing files and data, so business systems are up and running quickly and smoothly.

Dell Enterprise Support Services

Dell ProSupport Enterprise Suite

With the ProSupport Enterprise Suite, we help keep IT systems running smoothly, so customers can focus on running their business. We help maintain peak performance and availability of the most essential workloads. ProSupport Enterprise Suite is a suite of support services that enable customers to build the solution that is right for their organization. They choose support models that are based on how they use technology and where they want to allocate resources. From the desktop to the data

center, address everyday IT challenges, such as unplanned downtime, mission-critical needs, data and asset protection, support planning, resource allocation, software application management and more. Optimize customer IT resources by choosing the right support model.

Table 25. ProSupport Enterprise Suite

Service	Support model	Description
ProSupport Enterprise Suite	ProSupport Plus for Enterprise	Proactive, predictive, and reactive support for systems that look after your business-critical applications and workloads
	ProSupport for Enterprise	Comprehensive 24 x 7 predictive and reactive support for hardware and software
	Basic hardware support	Reactive hardware support during normal business hours

Dell ProSupport Plus for Enterprise

When customers purchase PowerEdge server, we recommend ProSupport Plus, our proactive and preventative support service for business-critical systems. ProSupport Plus provides all the benefits of ProSupport, plus the following:

- An assigned Services Account Manager who knows their business and environment
- Immediate advanced troubleshooting from an engineer
- Personalized, preventive recommendations that are based on analysis of support trends and best practices from across the Dell Technologies infrastructure solutions customer base to reduce support issues and improve performance
- Predictive analysis for issue prevention and optimization that is enabled by secure connect gateway technology
- Proactive monitoring, issue detection, notification, and automated case creation for accelerated issue resolution enabled by secure connect gateway
- On-demand reporting and analytics-based recommendations that are enabled by secure connect gateway and TechDirect

Dell ProSupport for Enterprise

ProSupport service offers highly trained experts around the clock and around the globe to address IT needs. We help minimize disruptions and maximize availability of PowerEdge server workloads with:

- 24x7 support through phone, chat and online
- Predictive, automated tools and innovative technology
- A central point of accountability for all hardware and software issues
- Collaborative third-party support
- Hypervisor, operating system and application support
- Consistent experience regardless of where customers are located or what language they speak

 **NOTE:** Subject to service offer country or region availability.

- Optional onsite parts and labor response options including next business day or four-hour mission critical

ProSupport Enterprise Suite Feature Comparison

	Basic	ProSupport	ProSupport Plus
Remote technical support	9x5	24x7	24x7
Covered products	Hardware	Hardware Software	Hardware Software
Onsite hardware support	Next business day	Next business day or 4hr mission critical	Next business day or 4 hr mission critical
3 rd party collaborative assistance		●	●
Self-service case initiation and management		●	●
Access to software updates		●	●
Proactive storage health monitoring, predictive analytics and anomaly detection with CloudIQ and the CloudIQ mobile app		●	●
Priority access to specialized support experts			●
Predictive detection of hardware failures			●
3 rd party software support			●
An assigned Service Account Manager			●
Proactive, personalized assessments and recommendations			●
Proactive systems maintenance			●

Availability and terms of Dell Technologies Services vary by region and by product. For more information, please view our [service descriptions](#).

Internal Use - Confidential 23 of 117 © Copyright 2022 Dell Inc. DELL Technologies

Figure 41. ProSupport Enterprise Suite

Dell ProSupport One for Data Center

ProSupport One for Data Center offers flexible site-wide support for large and distributed data centers with more than 1,000 assets. This offering is built on standard ProSupport components that leverage our global scale but are tailored to a customer's needs. While not for everyone, this service option offers a truly unique solution for Dell Technologies largest customers with the most complex environments.

- Team of assigned Services Account Managers with remote, on-site options
- Assigned ProSupport One technical and field engineers who are trained on the customer's environment and configurations
- On-demand reporting and analytics-based recommendations that are enabled by secure connect gateway and TechDirect
- Flexible on-site support and parts options that fit their operational model
- A tailored support plan and training for their operations staff

Dell ProSupport Add-on for HPC

The ProSupport Add-on for HPC provides solution-aware support including:

- Access to senior HPC experts
- Advanced HPC cluster assistance: performance, interoperability, and configuration
- Enhanced HPC solution level end-to-end support
- Remote presupport engagement with HPC Specialists during ProDeploy implementation

Learn more at Dell.com/HPC-Services.

ProSupport Add-on for HPC is an add-on to PS or PSP

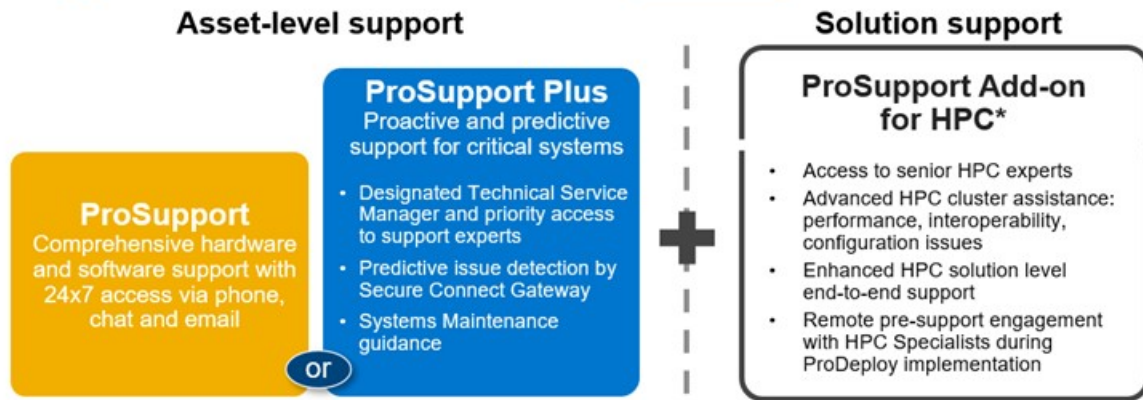

Eligibility

- All server, storage, and networking nodes in cluster must have PS or PSP **AND** PS Add-on for HPC attached
- All HW expansions to clusters must attach PS or PSP **AND** PS Add-on for HPC
- To retrofit an entire existing cluster with PS Add-on for HPC:
 1. HPC Specialists must review and validate the existing cluster
 2. PS or PSP **AND** the PS Add-on for HPC (APOS) must be attached to all server, storage and networking nodes

*Available in standard SKUs in NA and EMEA and as custom quote in APJC & LATAM

DELLTechnologies

Figure 42. ProSupport Add-on for HPC is an add-on to PS or PSP

Support Technologies

Powering the support experience with predictive, data-driven technologies.

NOTE: SupportAssist Enterprise capabilities are now part of the secure connect gateway technology.

Enterprise connectivity

The best time to solve a problem is before it happens. The automated proactive and predictive support features enabled by the secure connect gateway technology helps reduce steps and time to resolution, often detecting issues before they become a crisis. The gateway technology is available in virtual and application editions. It is also implemented as a direct connect version for select Dell hardware and a Services plugin within OpenManage Enterprise for PowerEdge servers. The legacy SupportAssist Enterprise solution has been retired and is now replaced by the secure connect gateway solutions.

Benefits include:

- Value: Our connectivity solutions are available to all customers at no additional charge
- Improve productivity: Replace manual, high-effort routines with automated support
- Accelerate time to resolution: Receive issue alerts, automatic case creation, and proactive contact from Dell experts
- Gain insight and control: Optimize enterprise devices with insights in portals reporting like TechDirect, and get predictive issue detection before the problem starts

NOTE: Connect devices can access these features. Features vary depending on the service level agreement for the connected device. ProSupport Plus customers experience the full set of automated support capabilities.

Table 26. Features enabled by connectivity

	Basic hardware warranty	ProSupport	ProSupport Plus
Automated issue detection and system state information collection	Supported	Supported	Supported
Proactive, automated case creation and notification	Not supported	Supported	Supported

Table 26. Features enabled by connectivity (continued)

	Basic hardware warranty	ProSupport	ProSupport Plus
Predictive issue detection for failure prevention	Not supported	Not supported	Supported

Get started at DellTechnologies.com/secureconnectgateway.

Dell TechDirect

TechDirect helps boost IT team productivity when supporting Dell systems.

Boost your productivity with online service for Dell products from TechDirect. From deployment to technical support, TechDirect lets you do more with less effort and faster resolution. You can:

- Open and manage support requests or in-warranty systems
- Execute online self-service for parts dispatch
- Collaborate on ProDeploy infrastructure deployment projects online
- Manage proactive and predictive alerts from secure connect gateway technology that help maximize uptime
- Integrate services functionality into your help desk with TechDirect APIs
- Join over 10,000 companies that choose TechDirect

Register at TechDirect.Dell.com.

Dell Technologies Consulting Services

Our expert consultants help customers transform faster, and quickly achieve business outcomes for the high value workloads Dell PowerEdge systems can handle. From strategy to full-scale implementation, Dell Technologies Consulting can help determine how to perform IT, workforce, or application transformation. We use prescriptive approaches and proven methodologies that are combined with portfolio and partner ecosystem of Dell Technologies to help achieve real business outcomes. From multi cloud, applications, DevOps, and infrastructure transformations, to business resiliency, data center modernization, analytics, workforce collaboration, and user experiences-we are here to help.

Dell Managed Services

Some customers prefer Dell to manage the complexity and risk of daily IT operations, Dell Managed Services utilizes proactive, AI enabled delivery operations and modern automation to help customers realize desired business outcomes from their infrastructure investments. With these technologies, our experts run, update and fine-tune customer environments aligned with service levels, while providing environment-wide and down-to-the-device visibility. There are two types of managed service offers. First the outsourcing model or CAPEX model where Dell manages the customer owned assets using our people and tools. The second is the as-a-Service model or OPEX model called APEX. In this service, Dell owns all technology and all the management of it. Many customers will have a blend of the two management types depending on the goals of the organization.

Managed	Outsourcing or CAPEX model	APEX	as-a-Service or OPEX model
<p>We manage your technology using our people and tools.¹</p> <ul style="list-style-type: none"> • Managed detection and response* • Technology Infrastructure • End-user (PC/desktop) • Service desk operations • Cloud Managed (Pub/Private) • Office365 or Microsoft Endpoint 		<p>We own all technology so you can off-load all IT decisions.</p> <ul style="list-style-type: none"> • APEX Cloud Services • APEX Flex on Demand elastic capacity • APEX Data Center Utility pay-per-use model 	

1 – Some minimum device counts may apply. Order via: ClientManagedServices.sales@dell.com

* Managed detection and response covers the security monitoring of laptops, servers, & virtual servers. Min. 50 devices combined. No Networking or Storage-only systems [SAN/NAS]. Available in 32 countries. [Details here](#)

Figure 43. Dell Managed Services

Managed Detection and Response (MDR)

Dell Technologies Managed Detection and Response (MDR) is powered by Secureworks Taegis XDR software platform. MDR is a managed service that secures the customer's IT environment against malicious actors and provides remediation if and when a threat is identified. When a customer purchases MDR, they will receive the following features from our team:

- Dell badge resources
- Agent rollout assistance to help deploy the Secureworks Endpoint Agent
- 24x7 threat detection & investigation
- Up to 40hrs per quarter of response and active remediation activities
- If the customer experiences a breach, we will provide up to 40hrs per year of Cyber incident response initiation
- Quarterly reviews with the customer to review the data

Dell Technologies Education Services

Build the IT skills required to influence the transformational outcomes of the business. Enable talent and empower teams with the right skills to lead and perform transformational strategy that drives competitive advantage. Leverage the training and certification required for real transformation.

Dell Technologies Education Services offers PowerEdge server training and certifications that are designed to help customers achieve more from their hardware investment. The curriculum delivers the information and the practical, firsthand skills that their team must confidently install, configure, manage, and troubleshoot Dell servers.

To learn more or register for a class today, see Education.Dell.com.

Appendix A: Additional specifications

Topics:

- Chassis dimensions
- Chassis weight
- NIC port specifications
- Video specifications
- USB Ports
- PSU rating
- Environmental specifications

Chassis dimensions

The R860 has the following dimensions:

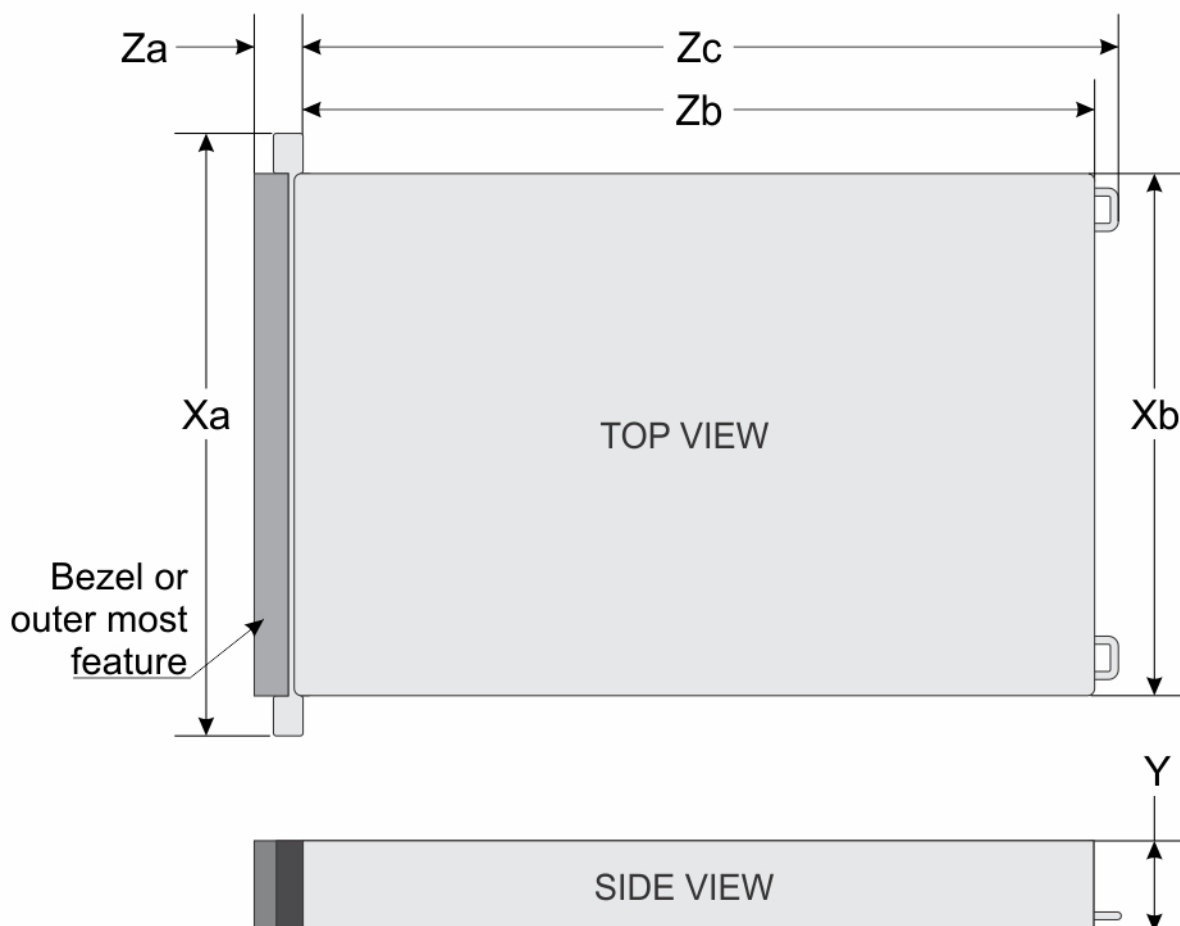

Figure 44. Chassis dimensions

Table 27. Chassis dimensions

Model number	Xa	Xb	Y	Za with bezel	Za without bezel	Zb	Zc	Mx system Wgt.	Chassis
R860	482.0 mm (18.97 inches)	444.0 mm (17.48 inches)	86.8 mm (3.41 inches)	36.0 mm (1.41 inches)	22.0 mm (0.86 inches)	817.23 mm (32.17 inches) Ear to rear wall	848.3 mm (33.39 inches) Ear to PSU handle	42.97 kg (94.73 lbs)	2U

NOTE: Zb is the nominal rear wall external surface where the system board I/O connectors reside.

Chassis weight

Table 28. Chassis weight

System configuration	Maximum weight (with all drives/SSDs)
A server with fully populated drives	42.97 kg (94.73 lbs)
A server without drives and PSU installed	13.09 kg (28.85 lbs)

NIC port specifications

The PowerEdge R860 system supports up to two 10/100/1000 Mbps Network Interface Controller (NIC) ports embedded on the LAN on Motherboard (LOM) and integrated on the optional Open Compute Project (OCP) cards.

Table 29. NIC port specification for the system

Feature	Specifications
LOM card (optional)	1 GbE x 2
OCP card (OCP 3.0) (optional)	1 GbE x 4, 10 GbE x 2, 10 GbE x 4, 25 GbE x 2, 25 GbE x 4, 100 GbE x 2

NOTE: The system allows either LOM card or an OCP card or both to be installed in the system.

Video specifications

The PowerEdge R860 system supports integrated Matrox G200 graphics controller with 16 MB of video frame buffer.

Table 30. Supported video resolution options

Resolution	Refresh rate (Hz)	Color depth (bits)
1024 x 768	60	8, 16, 32
1280 x 800	60	8, 16, 32
1280 x 1024	60	8, 16, 32
1360 x 768	60	8, 16, 32
1440 x 900	60	8, 16, 32
1600 x 900	60	8, 16, 32
1600 x 1200	60	8, 16, 32

Table 30. Supported video resolution options (continued)

Resolution	Refresh rate (Hz)	Color depth (bits)
1680 x 1050	60	8, 16, 32
1920 x 1080	60	8, 16, 32
1920 x 1200	60	8, 16, 32

USB Ports



Figure 45. Front USB Port



Figure 46. Rear USB Port

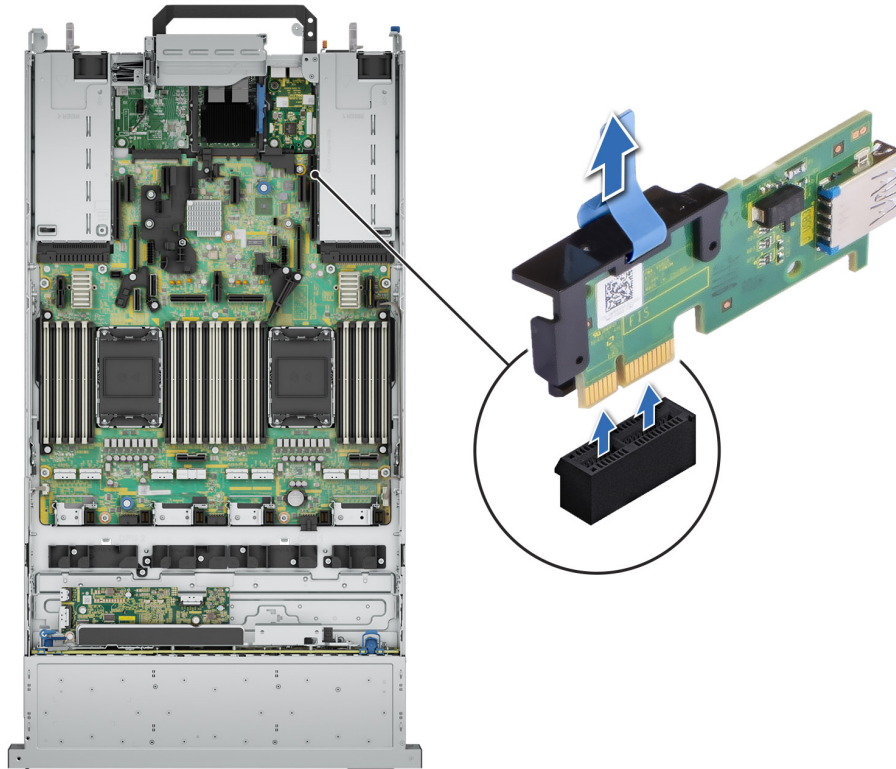

Figure 47. Internal USB Port

Table 31. System USB Specifications

Front		Rear		Internal	
USB port type	No. of ports	USB port type	No. of ports	USB port type	No. of ports
USB x.2.0 – compliant port	1	USB x.2.0 – compliant port	1	USB x.3.0 – compliant port	1
		USB x.3.0 – compliant port	1		

PSU rating

Below table lists the power capacity the PSUs in high/low line operation mode.

Table 32. PSUs highline and lowline ratings

Features	1100 W Titanium	1400 W Platinum	1800 W Titanium	2400 W Platinum	2800 W Titanium
Peak Power (Highline/-72 VDC)	1870 W	2380 W	3060 W	4080 W	4760 W
Highline/-72 VDC	1100 W	1400 W	1800 W	2400 W	2800 W
Peak Power (Lowline/-40 VDC)	1785 W	1785 W	N/A	2380 W	N/A
Lowline/-40 VDC	1050 W	1050 W	N/A	1400 W	N/A

Table 32. PSUs highline and lowline ratings (continued)

Features	1100 W Titanium	1400 W Platinum	1800 W Titanium	2400 W Platinum	2800 W Titanium
Highline 240 VDC	1100 W	1400 W	1800 W	2400 W	2800 W

The PowerEdge R860 supports up to two AC power supplies with 1+1 redundancy, autosensing, and auto switching capability.

If two PSUs are present during POST, a comparison is made between the wattage capacities of the PSUs. In case the PSU wattages do not match, the larger of the two PSUs is enabled. Also, there is a PSU mismatch warning that is displayed in BIOS, iDRAC, or on the system LCD.

If a second PSU is added at run-time, in order for that particular PSU to be enabled, the wattage capacity of the first PSU must equal the second PSU. Otherwise, the PSU is flagged as unmatched in iDRAC and the second PSU is not enabled.

Dell PSUs have achieved Platinum efficiency levels as shown in the table below.

Table 33. PSU efficiency level

Efficiency Targets by Load						
Form factor	Output	Class	10%	20%	50%	100%
Redundant 60 mm	1100 W AC	Titanium	90.00%	94.00%	96.00%	91.50%
	1400 W AC	Platinum	89.00%	93.00%	94.00%	91.50%
	1800 W AC	Titanium	90.00%	94.00%	96.00%	94.00%
Redundant 86 mm	2400 W AC	Platinum	89.00%	93.00%	94.00%	91.50%
	2800 W AC	Titanium	90.00%	94.00%	96.00%	94%

Environmental specifications

NOTE: For additional information about environmental certifications, refer to the *Product Environmental Datasheet* located with the *Documentation* on [Dell Support](#) page.

Table 34. Continuous Operation Specifications for ASHRAE A2

Temperature	Specifications
Allowable continuous operations	
Temperature range for altitudes <= 900 m (<= 2953 ft)	10–35°C (50–95°F) with no direct sunlight on the equipment
Humidity percent range (non-condensing at all times)	8% RH with -12°C (10.4°F) minimum dew point to 80% RH with 21°C (69.8°F) maximum dew point
Operational altitude de-rating	Maximum temperature is reduced by 1°C/300 m (1.8°F/984 Ft) above 900 m (2953 Ft)

Table 35. Continuous Operation Specifications for ASHRAE A3

Temperature	Specifications
Allowable continuous operations	
Temperature range for altitudes <= 900 m (<= 2953 ft)	5–40°C (41–104°F) with no direct sunlight on the equipment
Humidity percent range (non-condensing at all times)	8% RH with -12°C (10.4°F) minimum dew point to 85% RH with 24°C (75.2°F) maximum dew point

Table 35. Continuous Operation Specifications for ASHRAE A3 (continued)

Temperature	Specifications
Operational altitude de-rating	Maximum temperature is reduced by 1°C/175 m (1.8°F/574 Ft) above 900 m (2953 Ft)

Table 36. Continuous Operation Specifications for ASHRAE A4

Temperature	Specifications
Allowable continuous operations	
Temperature range for altitudes <= 900 m (<= 2953 ft)	5–45°C (41–113°F) with no direct sunlight on the equipment
Humidity percent range (non-condensing at all times)	8% RH with -12°C (10.4°F) minimum dew point to 90% RH with 24°C (75.2°F) maximum dew point
Operational altitude de-rating	Maximum temperature is reduced by 1°C/125 m (1.8°F/410 Ft) above 900 m (2953 Ft)

Table 37. Common Environmental Specifications for ASHRAE A2, A3 and A4

Temperature	Specifications
Allowable continuous operations	
Maximum temperature gradient (applies to both operation and non-operation)	20°C in an hour* (36°F in an hour) and 5°C in 15 minutes (9°F in 15 minutes), 5°C in an hour* (9°F in an hour) for tape hardware <i>i</i> NOTE: *Per ASHRAE thermal guidelines for tape hardware, these are not instantaneous rates of temperature change.
Non-operational temperature limits	-40 to 65°C (-40 to 149°F)
Non-operational humidity limits	5% to 95% RH with 27°C (80.6°F) maximum dew point
Maximum non-operational altitude	12,000 meters (39,370 feet)
Maximum operational altitude	3,050 meters (10,006 feet)

Table 38. Maximum vibration specifications

Maximum vibration	Specifications
Operating	0.21 G _{rms} at 5 Hz to 500 Hz for 10 minutes (all operation orientations)
Storage	1.88 G _{rms} at 10 Hz to 500 Hz for 15 minutes (all six sides tested)

Table 39. Maximum shock pulse specifications

Maximum shock pulse	Specifications
Operating	Six consecutively executed shock pulses in the positive and negative x, y, and z axis of 6 G for up to 11 ms
Storage	Six consecutively executed shock pulses in the positive and negative x, y, and z axis (one pulse on each side of the system) of 71 G for up to 2 ms

Particulate and gaseous contamination specifications

The following table defines the limitations that help avoid any equipment damage or failure from particulates and gaseous contamination. If the levels of particulates or gaseous pollution exceed the specified limitations and result in equipment damage or failure, you may need to rectify the environmental conditions. Remediation of environmental conditions is the responsibility of the customer.

Table 40. Particulate contamination specifications

Particulate contamination	Specifications
Air filtration	Data center air filtration as defined by ISO Class 8 per ISO 14644-1 with a 95% upper confidence limit <i>i</i> NOTE: This condition applies to data center environments only. Air filtration requirements do not apply to IT equipment designed to be used outside a data center, in environments such as an office or factory floor. <i>i</i> NOTE: Air entering the data center must have MERV11 or MERV13 filtration.
Conductive dust	Air must be free of conductive dust, zinc whiskers, or other conductive particles <i>i</i> NOTE: This condition applies to data center and non-data center environments.
Corrosive dust	<ul style="list-style-type: none"> Air must be free of corrosive dust Residual dust present in the air must have a deliquescent point less than 60% relative humidity <i>i</i> NOTE: This condition applies to data center and non-data center environments.
Walk-Up Edge Data Center or Cabinet (sealed, closed loop environment)	Filtration is not required for cabinets that are anticipated to be opened 6 times or less per year. Class 8 per ISO 1466-1 filtration as defined above is required otherwise <i>i</i> NOTE: In environments commonly above ISA-71 Class G1 or that may have known challenges, special filters may be required.

Table 41. Gaseous contamination specifications

Gaseous contamination	Specifications
Copper coupon corrosion rate	<300 Å/month per Class G1 as defined by ANSI/ISA71.04-2013
Silver coupon corrosion rate	<200 Å/month as defined by ANSI/ISA71.04-2013

Thermal restriction matrix

Table 42. Processor and heat sink matrix

Heat sink	Processor TDP
STD HSK	≤ 185 W
L-type HPR HSK	195 W–250 W
L-type VHPR HSK	≥ 270 W

Table 43. Label reference

Label	Description
HPR	High performance
VHPR	Very High Performance
HSK	Heat sink
LP	Low Profile
FH	Full Height

NOTE: The ambient temperature of the configuration is determined by the critical component in that configuration. For example, if the processor's supported ambient temperature is 35°C (95°F), the DIMM is 35°C (95°F), and the GPU is 30°C (86°F), the combined configuration can only support 30°C (86°F).

Table 44. Thermal restriction matrix for air cooled configurations

Configuration			24 x 2.5-inch NVMe	16 x 2.5-inch SAS + 8 x 2.5-inch NVMe	24 x 2.5-inch SAS			16 x 2.5-inch NVMe	16 x 2.5-inch SAS	8 x 2.5-inch SAS	8 x EDSFF E3.S	
Rear storage			No Rear Drives	No Rear Drives	No Rear Drives	2 x 2.5-inch SAS/NVMe	Rear 4 x EDSFF E3.S	No Rear Drives	No Rear Drives	No Rear Drives	No Rear Drives	
CPU SKUs	TDP	T-Case max center (°C)	Ambient temperature									
6416H	165 W	82	35°C (95°F)	35°C (95°F)	45°C (113°F)	35°C (95°F)	35°C (95°F)	35°C (95°F)	35°C (95°F)	45°C (113°F)	45°C (113°F)	35°C (95°F)
6418H	185 W	81	35°C (95°F)	35°C (95°F)	40°C (104°F)	35°C (95°F)	35°C (95°F)	35°C (95°F)	35°C (95°F)	40°C (104°F)	40°C (104°F)	35°C (95°F)
6434H	195 W	64	35°C (95°F)	35°C (95°F)	40°C (104°F)	35°C (95°F)	35°C (95°F)	35°C (95°F)	35°C (95°F)	40°C (104°F)	40°C (104°F)	35°C (95°F)
6448H	250 W	83	35°C (95°F)	35°C (95°F)	35°C (95°F)	35°C (95°F)	35°C (95°F)	35°C (95°F)	35°C (95°F)	35°C (95°F)	35°C (95°F)	35°C (95°F)
8450H ¹	250 W	76	35°C (95°F)	35°C (95°F)	35°C (95°F)	35°C (95°F)	35°C (95°F)	35°C (95°F)	35°C (95°F)	35°C (95°F)	35°C (95°F)	35°C (95°F)
8444H ¹	270 W	72	35°C (95°F)	35°C (95°F)	35°C (95°F)	35°C (95°F)	35°C (95°F)	35°C (95°F)	35°C (95°F)	35°C (95°F)	35°C (95°F)	35°C (95°F)
8454H ¹	270 W	71	35°C (95°F)	35°C (95°F)	35°C (95°F)	35°C (95°F)	35°C (95°F)	35°C (95°F)	35°C (95°F)	35°C (95°F)	35°C (95°F)	35°C (95°F)
8460H ¹	330 W	76	30°C (86°F)	30°C (86°F)	30°C (86°F)	30°C (86°F)	30°C (86°F)	30°C (86°F)	35°C (95°F)	35°C (95°F)	35°C (95°F)	35°C (95°F)
8468H ¹	330 W	77	30°C (86°F)	30°C (86°F)	30°C (86°F)	30°C (86°F)	30°C (86°F)	30°C (86°F)	35°C (95°F)	35°C (95°F)	35°C (95°F)	35°C (95°F)
8490H ¹	350 W	79	30°C (86°F)	30°C (86°F)	30°C (86°F)	30°C (86°F)	30°C (86°F)	30°C (86°F)	35°C (95°F)	35°C (95°F)	35°C (95°F)	35°C (95°F)
Memory			Ambient temperature									
256 GB RDIMM			35°C (95°F)	35°C (95°F)	35°C (95°F)	35°C (95°F)	35°C (95°F)	35°C (95°F)	35°C (95°F)	35°C (95°F)	35°C (95°F)	35°C (95°F)
128 GB RDIMM			35°C (95°F)	35°C (95°F)	35°C (95°F)	35°C (95°F)	35°C (95°F)	35°C (95°F)	35°C (95°F)	35°C (95°F)	35°C (95°F)	35°C (95°F)

Table 44. Thermal restriction matrix for air cooled configurations (continued)

Configuration	24 x 2.5-inch NVMe	16 x 2.5-inch SAS + 8 x 2.5-inch NVMe	24 x 2.5-inch SAS			16 x 2.5-inch NVMe	16 x 2.5-inch SAS	8 x 2.5-inch SAS	8 x EDSFF E3.S
			No Rear Drives	2 x 2.5-inch SAS/ NVMe	Rear 4 x EDSFF E3.S				
Rear storage	No Rear Drives	No Rear Drives	No Rear Drives	2 x 2.5-inch SAS/ NVMe	Rear 4 x EDSFF E3.S	No Rear Drives	No Rear Drives	No Rear Drives	No Rear Drives
96 GB RDIMM ¹	35°C (95°F)	35°C (95°F)	35°C (95°F)	35°C (95°F)	35°C (95°F)	35°C (95°F)	35°C (95°F)	35°C (95°F)	35°C (95°F)
64 GB RDIMM	N/A*								
32 GB RDIMM	N/A*								
16 GB RDIMM	N/A*								

NOTE: DIMM blanks must be installed in empty DIMM slots.

NOTE: *Memory has the same thermal restrictions of the processor used.

NOTE: ¹ Only the processors that are listed above can support 96 GB RDIMM.

Table 45. Thermal restriction matrix for Direct Liquid Cooled configurations

Configuration			24 x 2.5-inch NVMe	16 x 2.5-inch SAS + 8 x 2.5-inch NVMe	24 x 2.5-inch SAS			16 x 2.5-inch NVMe	16 x 2.5-inch SAS	8 x 2.5-inch SAS	8 x EDSFF E3.S
CPU SKUs	TDP	T-Case max center (°C)			No Rear Drives	2 x 2.5-inch SAS/ NVMe	Rear 4 x EDSFF E3.S				
6416H	165 W	82	35°C (95°F)	35°C (95°F)	45°C (113°F)	35°C (95°F)	35°C (95°F)	35°C (95°F)	45°C (113°F)	45°C (113°F)	35°C (95°F)
6418H	185 W	81	35°C (95°F)	35°C (95°F)	45°C (113°F)	35°C (95°F)	35°C (95°F)	35°C (95°F)	45°C (113°F)	45°C (113°F)	35°C (95°F)
6434H	195 W	64	35°C (95°F)	35°C (95°F)	45°C (113°F)	35°C (95°F)	35°C (95°F)	35°C (95°F)	45°C (113°F)	45°C (113°F)	35°C (95°F)
6448H	250 W	83	35°C (95°F)	35°C (95°F)	45°C (113°F)	35°C (95°F)	35°C (95°F)	35°C (95°F)	45°C (113°F)	45°C (113°F)	35°C (95°F)
8450H ¹	250 W	76	35°C (95°F)	35°C (95°F)	45°C (113°F)	35°C (95°F)	35°C (95°F)	35°C (95°F)	45°C (113°F)	45°C (113°F)	35°C (95°F)
8444H ¹	270 W	72	35°C (95°F)	35°C (95°F)	45°C (113°F)	35°C (95°F)	35°C (95°F)	35°C (95°F)	45°C (113°F)	45°C (113°F)	35°C (95°F)

Table 45. Thermal restriction matrix for Direct Liquid Cooled configurations (continued)

Configuration			24 x 2.5-inch NVMe	16 x 2.5-inch SAS + 8 x 2.5-inch NVMe	24 x 2.5-inch SAS			16 x 2.5-inch NVMe	16 x 2.5-inch SAS	8 x 2.5-inch SAS	8 x EDSFF E3.S
Rear storage			No Rear Drives	No Rear Drives	No Rear Drives	2 x 2.5-inch SAS/NVMe	Rear 4 x EDSFF E3.S	No Rear Drives	No Rear Drives	No Rear Drives	No Rear Drives
8454H ¹	270 W	71	35°C (95°F)	35°C (95°F)	45°C (113°F)	35°C (95°F)	35°C (95°F)	35°C (95°F)	45°C (113°F)	45°C (113°F)	35°C (95°F)
8460H ¹	330 W	76	35°C (95°F)	35°C (95°F)	45°C (113°F)	35°C (95°F)	35°C (95°F)	35°C (95°F)	45°C (113°F)	45°C (113°F)	35°C (95°F)
8468H ¹	330 W	77	35°C (95°F)	35°C (95°F)	45°C (113°F)	35°C (95°F)	35°C (95°F)	35°C (95°F)	45°C (113°F)	45°C (113°F)	35°C (95°F)
8490H ¹	350 W	79	35°C (95°F)	35°C (95°F)	45°C (113°F)	35°C (95°F)	35°C (95°F)	35°C (95°F)	45°C (113°F)	45°C (113°F)	35°C (95°F)
Memory			Ambient temperature								
256 GB RDIMM			35°C (95°F)	35°C (95°F)	35°C (95°F)	35°C (95°F)	35°C (95°F)	35°C (95°F)	35°C (95°F)	35°C (95°F)	35°C (95°F)
128 GB RDIMM			35°C (95°F)	35°C (95°F)	35°C (95°F)	35°C (95°F)	35°C (95°F)	35°C (95°F)	35°C (95°F)	35°C (95°F)	35°C (95°F)
96 GB RDIMM ¹			35°C (95°F)	35°C (95°F)	35°C (95°F)	35°C (95°F)	35°C (95°F)	35°C (95°F)	35°C (95°F)	35°C (95°F)	35°C (95°F)
64 GB RDIMM			N/A*								
32 GB RDIMM			N/A*								
16 GB RDIMM			N/A*								

NOTE: DIMM blanks must be installed in empty DIMM slots.

NOTE: *Memory has the same thermal restrictions of the processor used.

NOTE: ¹ Only the processors that are listed above can support 96 GB RDIMM.

Thermal air restrictions

Table 46. Air cooling thermal restriction for 24 x 2.5-inch NVMe/16 x 2.5-inch + 8 x NVMe/16 x NVMe Storage Configurations

ASHRAE	A2/35°C (95°F)	A3/40°C (104°F)	A4/45°C (113°F)
Processor	CPUs ≥ 330 W are not supported. Maximum 30°C for CPU ≥ 330 W	CPUs ≤ 195 W are supported.	Only 165 W is supported
PSU	Two PSUs are required in redundant mode. If there is a PSU failure, system performance may be reduced.		
PCIe card	Non-Dell qualified peripheral cards and peripheral cards greater than 25 W are not supported.		

Table 46. Air cooling thermal restriction for 24 x 2.5-inch NVMe/16 x 2.5-inch + 8 x NVMe/16 x NVMe Storage Configurations (continued)

ASHRAE	A2/35°C (95°F)	A3/40°C (104°F)	A4/45°C (113°F)
GPU/FPGA	Not supported		
DIMM	256 GB RDIMMs only support 1DPC Maximum 35°C for 128 GB RDIMM or greater capacity RDIMMs	128 GB, or greater capacity DIMMs are not supported.	
NVMe storage	2.5-inch NVMe storage is supported.	2.5-inch NVMe storage is not supported.	
OCP	OCP cooling tier >5 is supported	OCP cooling tier >5 is not supported 85°C active optics cable is required	
BOSS	BOSS-N1 is supported.	BOSS-N1 is not supported.	

Table 47. Air cooling configurations thermal restriction for 8 x 2.5-inch/16 x 2.5-inch Storage Configuration

ASHRAE	A2/35°C (95°F)	A3/40°C (104°F)	A4/45°C (113°F)
Processor	CPUs ≥ 330 W are not supported. Maximum 30°C for CPU ≥ 330 W	CPUs ≤ 195 W are supported.	Only 165 W is supported
PSU	Two PSUs are required in redundant mode. If there is a PSU failure, system performance may be reduced.		
PCIe card	Non-Dell qualified peripheral cards and peripheral cards greater than 25 W are not supported.		
GPU/FPGA	Not supported		
DIMM	256 GB RDIMMs only support 1DPC Maximum 35°C for 128 GB RDIMM or greater capacity RDIMMs	128 GB, or greater capacity DIMMs are not supported.	
NVMe storage	2.5-inch NVMe storage is not supported.		
OCP	OCP cooling tier >5 is supported	OCP cooling tier >5 is not supported 85°C active optics cable is required	
BOSS	BOSS-N1 is supported.	BOSS-N1 is not supported.	

Appendix B. Standards compliance

The system conforms to the following industry standards.

Table 48. Industry standard documents

Standard	URL for information and specifications
ACPI Advance Configuration and Power Interface Specification, v6.4	ACPI
Ethernet IEEE Std 802.3-2022	IEEE Standards
MSFT WHQL Microsoft Windows Hardware Quality Labs	Windows Hardware Compatibility Program
IPMI Intelligent Platform Management Interface, v2.0	IPMI
DDR5 Memory DDR5 SDRAM Specification	JEDEC Standards
PCI Express PCI Express Base Specification, v5.0	PCIe Specifications
PMBus Power System Management Protocol Specification, v1.2	Power System Management Protocol Specification
SAS Serial Attached SCSI, 3 (SAS-3) (T10/INCITS 519)	SCSI Storage Interfaces
SATA Serial ATA Rev. 3.3	SATA IO
SMBIOS System Management BIOS Reference Specification, v3.3.0	DMTF SMBIOS
TPM Trusted Platform Module Specification, v1.2 and v2.0	TPM Specifications
UEFI Unified Extensible Firmware Interface Specification, v2.7	UEFI Specifications
PI Platform Initialization Specification, v1.7	
USB Universal Serial Bus v2.0 and SuperSpeed v3.0 (USB 3.1 Gen1)	USB Implementers Forum, Inc. USB
NVMe Express Base Specification. Revision 2.0c	NVMe
NVMe Command Set Specifications	
1. NVMe Express NVMe Command Set Specification. Revision 1.1c	
2. NVMe Express Zoned Namespaces Command Set. Revision 1.0c	
3. NVMe Express® Key Value Command Set. Revision 1.0c	
NVMe Transport Specifications	
1. NVMe Express over PCIe Transport. Revision 1.0c	
2. NVMe Express RDMA Transport Revision. 1.0b	
3. NVMe Express TCP Transport. Revision 1.0c	
NVMe NVMe Express Management Interface. Revision 1.2c	
NVMe NVMe Boot Specification. Revision 1.0	

Appendix C Additional resources

Table 49. Additional resources

Resource	Description of contents	Location
Installation and Service Manual	<p>This manual, available in PDF format, provides the following information:</p> <ul style="list-style-type: none"> • Chassis features • System Setup program • System indicator codes • System BIOS • Remove and replace procedures • Diagnostics • Jumpers and connectors 	Support Manuals
Getting Started Guide	<p>This guide ships with the system, and is also available in PDF format. This guide provides the following information:</p> <ul style="list-style-type: none"> • Initial setup steps 	Support Manuals
Rack Installation Guide	<p>This document ships with the rack kits, and provides instructions for installing a server in a rack.</p>	Support Manuals
System Information Label	<p>The system information label documents the system board layout and system jumper settings. Text is minimized due to space limitations and translation considerations. The label size is standardized across platforms.</p>	Inside the system chassis cover
QR code for system resources	<p>This code on the chassis can be scanned by a phone application to access additional information and resources for the server, including videos, reference materials, service tag information, and Dell contact information.</p>	Inside the system chassis cover
Enterprise Infrastructure Planning Tool (EIPT)	<p>The Dell online EIPT enables easier and more meaningful estimates to help you determine the most efficient configuration possible. Use EIPT to calculate the power consumption of your hardware, power infrastructure, and storage.</p>	Calc