

Dell PowerEdge XR8000r, XR8610t and XR8620t

Technical Guide

Notes, cautions, and warnings

 **NOTE:** A NOTE indicates important information that helps you make better use of your product.

 **CAUTION:** A CAUTION indicates either potential damage to hardware or loss of data and tells you how to avoid the problem.

 **WARNING:** A WARNING indicates a potential for property damage, personal injury, or death.

Chapter 1: System overview	5
Key workloads.....	5
New technologies.....	6
Chapter 2: System features	7
Chapter 3: Heater Manager subsystem	10
Chapter 4: Chassis views and features	11
Chassis views.....	11
Front view of the system.....	11
Rear view of the system.....	13
Inside view of the system.....	14
Chapter 5: Processor	17
Processor features	17
Supported processors.....	18
Chapter 6: Memory subsystem	19
Supported memory.....	19
Chapter 7: Storage	20
Supported Drives.....	20
Chapter 8: Networking	21
Overview.....	21
Integrated LOM.....	21
Chapter 9: PCIe subsystem	22
PCIe subsystem overview.....	22
PCIe risers.....	22
PCIe slot power.....	25
Slot priority matrix.....	27
Expansion card installation guidelines.....	28
Expansion card installation guidelines.....	30
Chapter 10: Power, thermal, and acoustics	33
Power.....	33
Power Supply Units.....	34
Cable Routing Procedure.....	34
Thermal.....	37
XR8000 Thermal Restrictions.....	37
Multi Vector Cooling.....	37

Environmental specifications.....	37
PowerEdge XR8000 acoustics.....	52
Chapter 11: Rails and mounting options.....	54
Chapter 12: Operating Systems and Virtualization.....	56
Supported operating systems.....	56
Supported Virtualization.....	56
Chapter 13: Dell Systems Management.....	57
Integrated Dell Remote Access Controller (iDRAC).....	57
Systems Management software support matrix.....	58
Chapter 14: Appendix D: Service and support.....	60
Default support levels.....	60
Default deployment levels.....	60
Other services and support information.....	60
Dell deployment services.....	60
Dell custom deployment Services.....	64
Dell Residency Services.....	64
Dell Data Migration Services.....	64
Dell Enterprise Support Services.....	65
Enterprise connectivity.....	67
Dell TechDirect.....	68
Dell Technologies Consulting Services.....	68
Chapter 15: Appendix A. Additional specifications.....	70
Chassis dimensions	70
System weight.....	71
Video specifications.....	71
PSU specifications.....	72
System board jumpers and connectors	73
Chapter 16: Appendix B. Standards compliance.....	77
Chapter 17: Appendix C Additional resources.....	78
Chapter 18: Appendix D: Service and support.....	79
Default support levels.....	79
ProDeploy Infrastructure Suite.....	79
Supplemental Deployment Services.....	82
Unique Deployment Scenarios.....	83
DAY 2 - Automation Services with Ansible.....	84
ProSupport Infrastructure Suite.....	84
Specialty Support Services.....	86
Consulting Services.....	87
Resources.....	88

System overview

The PowerEdge XR8000 is Dell's latest server offering that comes with chassis XR8000r. The chassis can be populated with XR8610t and XR8620t sleds. The server sleds are designed to run complex workloads using highly scalable memory, I/O, and network options.

XR8000r

The Dell PowerEdge XR8000r system is a 2U multi-node rackmount chassis that supports:

- Up to four 1U, half-width compute sleds or up to two 2U, half-width compute sled or mix of up to two 1U and one 2U half-width compute sleds.
- Compute sleds - XR8610t and XR8620t
- Up to two redundant AC or DC power supply units
- Front bezel with bezel filter.

XR8610t

The Dell PowerEdge XR8610t system is a half-width 1U compute sled that supports:

- One 5th Generation Intel Xeon Scalable processor up to 16 cores or one 4th Generation Intel Xeon Scalable processor up to 32 cores
- Eight DDR5 DIMM slots
- BOSS-N1 with 2 x 2280 NVMe SSDs, or single M.2 riser with 1 x 2280 M.2 SSD, or dual M.2 riser with 2 x M.2 2280 or 22110 SSDs.

XR8620t

The PowerEdge XR8620t system is a half-width 2U compute sled that supports:

- One 5th Generation Intel Xeon Scalable processor up to 16 cores or one 4th Generation Intel Xeon Scalable processor up to 32 cores
- Eight DDR5 DIMM slots
- BOSS-N1 with 2 x 2280 NVMe SSDs, or single M.2 riser with 1 x 2280 M.2 SSD.
 - 2 x M.2 2280 or 22110 on ROR-N1 (RAISER) with RAID 0/1 (Upper U of XR8620t sled)
 - 2 x M.2 2280 or 22110 on Dual M.2 NVMe direct riser module (non-RAID) (Upper U of XR8620t sled)

Topics:

- [Key workloads](#)
- [New technologies](#)

Key workloads

The Dell PowerEdge XR8610t and XR8620t sleds are designed and optimized for telecom and edge use cases like:

- Centralized RAN
- Distributed RAN
- Network Edge
- Manufacturing
- Retail

New technologies

Table 1. New technologies featured on XR8000r

Technology	Detailed description
Chassis Orientation	<ul style="list-style-type: none"> • 2U sheet metal chassis. • Support for two 2U nodes, four 1U nodes, or a mix of two 1U and one 2U node. • Support for two 60MM Reverse Airflow (RAF) PSUs. AC and DC options are available. • No connection or service items in the rear of the chassis. • Passive ears with no electronics. • Options for different mid chassis mount ear locations to allow proper placement in different racks.
Power Supplies	<ul style="list-style-type: none"> • XR8000 supports all Dell 60mm Reverse Airflow modules. • Support RAF 800W -48V DC, RAF 1100W -48V DC, RAF 1400W AC, RAF 1400W -48V DC and RAF 1800W AC PSUs.

Table 2. New technologies featured on XR8610t and XR8620t

Technology	Detailed description
Intel Xeon Scalable processor (SPR-SP)	Core count: Up to 32 cores processor
	Maximum number of PCIe lanes per CPU: Integrated 80 PCIe 5.0 lanes @ 32GT/s PCIe Gen5
	Maximum TDP: 205W
Intel Xeon Edge-Enhanced processor (SPR-EE)	Core count: Up to 32 cores processor
	Maximum number of PCIe lanes per CPU: Integrated 80 PCIe 4.0 lanes @ 32GT/s PCIe Gen4 80 lanes reduced to 64 lanes with EE MCC CPU and 48 lanes with EE LCC CPU.
	Maximum TDP: 205W
Intel Xeon Edge-Enhanced processor (SPR-EE LCC mainline)	Core count: Up to 12 core processor (24 threads)
	Maximum number of PCIe lanes per CPU: Integrated 80 PCIe 5.0 lanes @ 32GT/s PCIe Gen 5
	Maximum TDP 150W
Intel Xeon Scalable Processor Emerald Rapids (EMR-SP)	Core count: Up to 16 core processor (32 threads)
	Maximum number of PCIe lanes per CPU: Integrated 80 PCIe 5.0 lanes @ 32GT/s PCIe Gen 5
	Maximum TDP 150W
5600 MT/s DDR5 Memory	<ul style="list-style-type: none"> • Up to 8 DIMMs in total. • Supports DDR5 ECC RDIMM (Max: 64GB per DIMM) <p>NOTE: 5600 MT/s DDR5 Memory is required with Emerald Rapids CPUs</p>
iDRAC9 w/ Lifecycle Controller	The embedded systems management solution for Dell servers features hardware and firmware inventory and alerting, in-depth memory alerting, faster performance, a dedicated gigabit port and many more features.

System features

Table 3. Features of PowerEdge XR8000r

Feature	PowerEdge XR8000r
Power supply	1800 W Mixed Mode/ 200 - 240 V AC / 240 V DC
	1400 W Mixed Mode / 100 - 240 V AC / 240 V DC
	1400 W DC / -48 -(-60) V
	1100 W DC / -48 -(-60) V
	800 W DC / -48 -(-60) V
Form factor	2U rackable chassis
Dimensions and weight	
Height	87.05 mm (3.42 inches)
Width	<ul style="list-style-type: none"> 482 mm (18.97 inches) with mount ear 448 mm (17.63 inches) without mount ear
Depth	<ul style="list-style-type: none"> 423 mm (16.65 inches) cable management to rear wall 343 mm (13.50 inches) mounting surface to rear wall
Weight	5.82 kg (12.80 pound) without sleds
	22.76 kg (50.17 pound) with sleds

Table 4. Features of PowerEdge XR8610t

Feature	PowerEdge XR8610t
Processor	One 4th Generation Intel Xeon Scalable processor with up to 32 cores
Chipset	Intel® C741 Series Chipset
Accelerators	NA
Memory	
DIMM speed	Up to 4800 MT/s
Memory type	RDIMM
Memory module slots	8 x DDR5 DIMM slots
Storage	BOSS-N1 with 2 x 2280 NVMe SSDs, or single M.2 riser with 1 x 2280 M.2 SSD, or dual M.2 riser with 2 x M.2 2280 or 22110 SSDs.
Storage controllers	
Internal boot	2 x M.2 2280 BOSS-N1 with RAID 0/1
Software RAID	N/A
System management	LC 3.x, OpenManage, OMPC3, Digital License Key, iDRAC Direct (dedicated micro-USB port), Easy Restore, iDRAC9 RJ45 (dedicated port)
Ports	

Table 4. Features of PowerEdge XR8610t (continued)

Feature	PowerEdge XR8610t
Network port	2 x 25 GbE SFP 28 on board LOM (Optional)
Front port	1 x USB 3.0
	1 x iDRAC Direct (Micro-AB USB) port
	1 x Micro-USB Serial port
	1 x Mini-DisplayPort
	1 x RJ-45 iDRAC9 remote management (dedicated port only)
	1 x RJ45 Alert\Dry contact input connector
Internal port	N/A
Form factor	1U single-width sled
Slots	
PCIe	1 x16 PCIe (Gen5) slot
Dimensions and weight	
Height	41.25 mm (1.62 inches)
Width	184.8 mm (7.28 inches)
Depth	433.5 mm (17.07 inches)
Maximum Weight	3.90 kg (8.59 pounds)

Table 5. Features of PowerEdge XR8620t

Feature	PowerEdge XR8620t
Processor	One 4th Generation Intel Xeon Scalable processor with up to 32 cores
Chipset	Intel® C741 Series Chipset
Heater Management subsystem	
Accelerators	NA
Memory	
DIMM speed	Up to 4800 MT/s
Memory type	RDIMM
Memory module slots	8 x DDR5 DIMM slots
Storage	<ul style="list-style-type: none"> BOSS-N1 with 2 x 2280 NVMe SSDs, or single M.2 riser with 1 x 2280 M.2 SSD (Lower U of the sled) 2 x M.2 2280 or 22110 on ROR-N1 (RAISER) with RAID 0/1 (Upper U of XR8620t sled) 2 x M.2 2280 or 22110 on Dual M.2 NVMe direct riser module (non-RAID) (Upper U of XR8620t sled)
Storage controllers	
Internal boot	<ul style="list-style-type: none"> 2 x M.2 2280 BOSS-N1 with RAID 0/1
Software RAID	N/A
System management	LC 3.x, OpenManage, OMPC3, Digital License Key, iDRAC Direct (dedicated micro-USB port), Easy Restore, iDRAC9 RJ45 (dedicated port)

Table 5. Features of PowerEdge XR8620t (continued)

Feature	PowerEdge XR8620t
Ports	
Network port	2 x 25 GbE SFP 28 on board LOM (Optional)
Front port	1 x USB 3.0
	1 x iDRAC Direct (Micro-AB USB) port
	1 x Micro-USB Serial port
	1 x Mini-DisplayPort
	1 x RJ-45 iDRAC9 remote management (dedicated port only)
	1 x RJ45 Alert\Dry contact input connector
Internal port	N/A
Form factor	2U single-width sled
Slots	
PCIe	Up to 3 x16 PCIe (Gen5) slots
Dimensions and weight	
Height	83.28 mm (3.28 inches)
Width	184.8 mm (7.28 inches)
Depth	433.5 mm (17.07 inches)
Weight	5.25 kg (11.57 pound)

Heater Manager subsystem

Heater Manager subsystem Summary

XR8000 needs to support an operating temperature range of -20 to 65°C with a non-operational range of -40 to 65°C. The following major components do not support an industrial range and may need to be heated before they can be powered on:

- Intel Xeon-SP SPR CPU – minimum temperature is 0°C
- Intel Emmitsburg PCH south bridge – minimum temperature is 0°C
- iDRAC temperature range of 0°C to 70°C
- CPLD temperature range of 0°C to 85°C
- DIMM memory – minimum temperature is 0°C
- M.2 drives – temperature range is 85°C with selected range of 0°C to 85°C
- Adapter cards – temperature ranges vary depending on the manufacturer.

i NOTE: Only XR8620t supports Heater Manager subsystem configuration.

i NOTE: Jumper cables should be installed in XR8620t heater solution configuration only. Jumper cables are to be installed only when there is no heater module installed in the system, and since the heater slots on 2U PDB continue to provide power in the absence of heater module, or jumper cables, it can cause a short circuit.

i NOTE: The jumper cables from heater slots 8,9 and 10 have to be transferred to the new PDB if the current PDB is being replaced and if the heater is not installed on the new PDB. The jumper cables are to be installed in heater 8, heater 9 and heater 10 slots on 2U PDB.

i NOTE: After pressing the power button, it takes approximately 4 minutes for the heater to warm the system from -20°C to 5°C before the power is applied to initiate system startup.

i NOTE: Heater Manger is tested to -20°C.

i NOTE: Heater Manager will monitor and maintain each heater zone's temperature while system is on.

i NOTE: All heater modules for XR8620t should be at point of sale.

i NOTE: No APOS Cust kit for heater modules is available. The XR8620t heater module (ET) involves complex hardware connections, including thermal/heater pad/sensors, etc. Due to this complexity, it is not easy for customers to modify the configuration after shipment or change any M.2s connected to ROR-N1.

Chassis views and features

Topics:

- Chassis views

Chassis views

Front view of the system

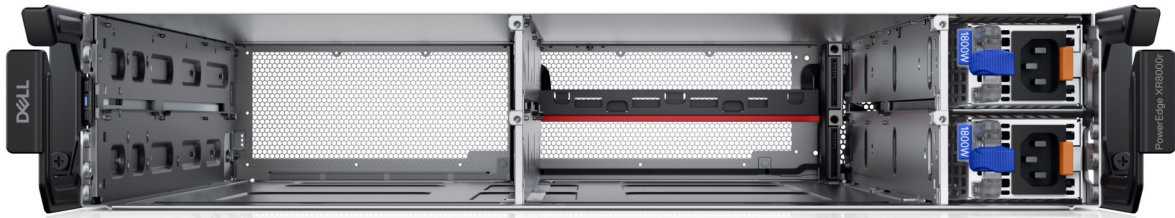

Figure 1. Front view of the chassis XR8000r - unpopulated



Figure 2. Front view of the chassis XR8000r - populated



Figure 3. Front view of the system XR8610t



Figure 4. Front view of the system XR8620t

Rear view of the system

Rear view of XR8000r

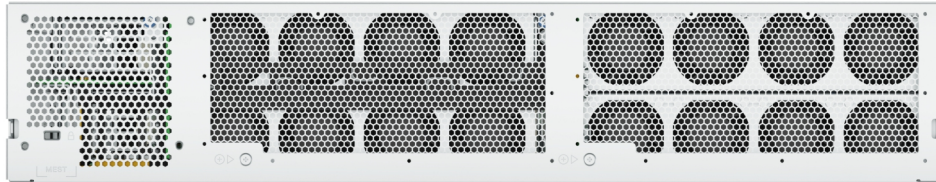

Figure 5. Rear view of the system

Rear view of XR8610t

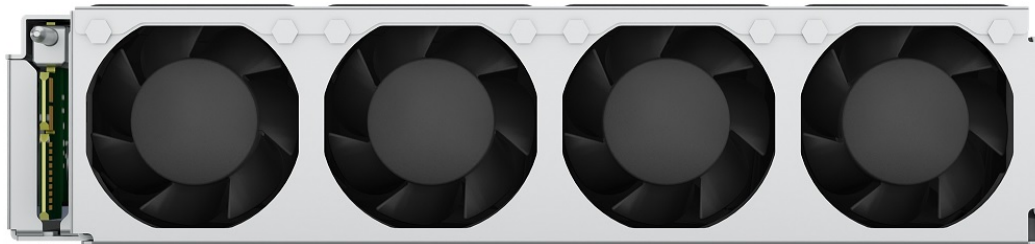

Figure 6. Rear view of the system

Rear view of XR8620t

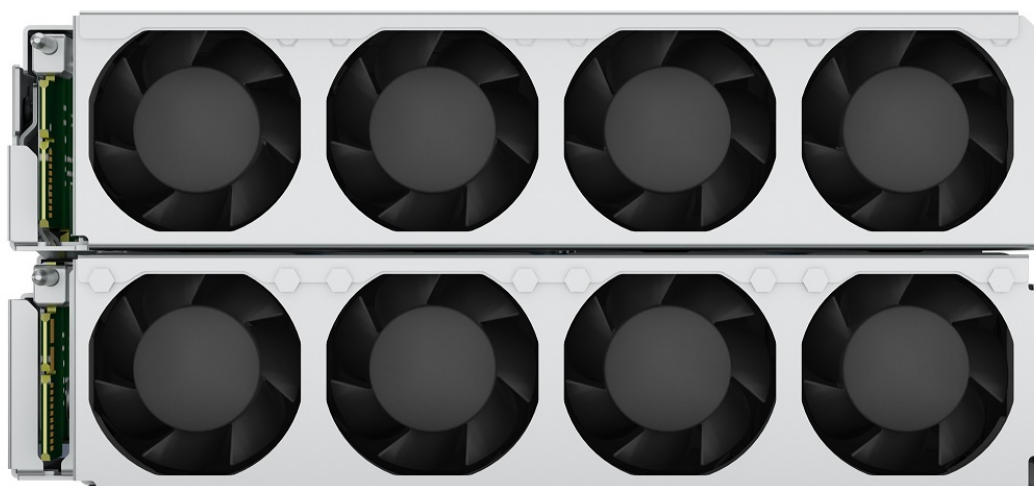

Figure 7. Rear view of the system

Inside view of the system

Inside view of 2U Sled with top cover and Riser 1

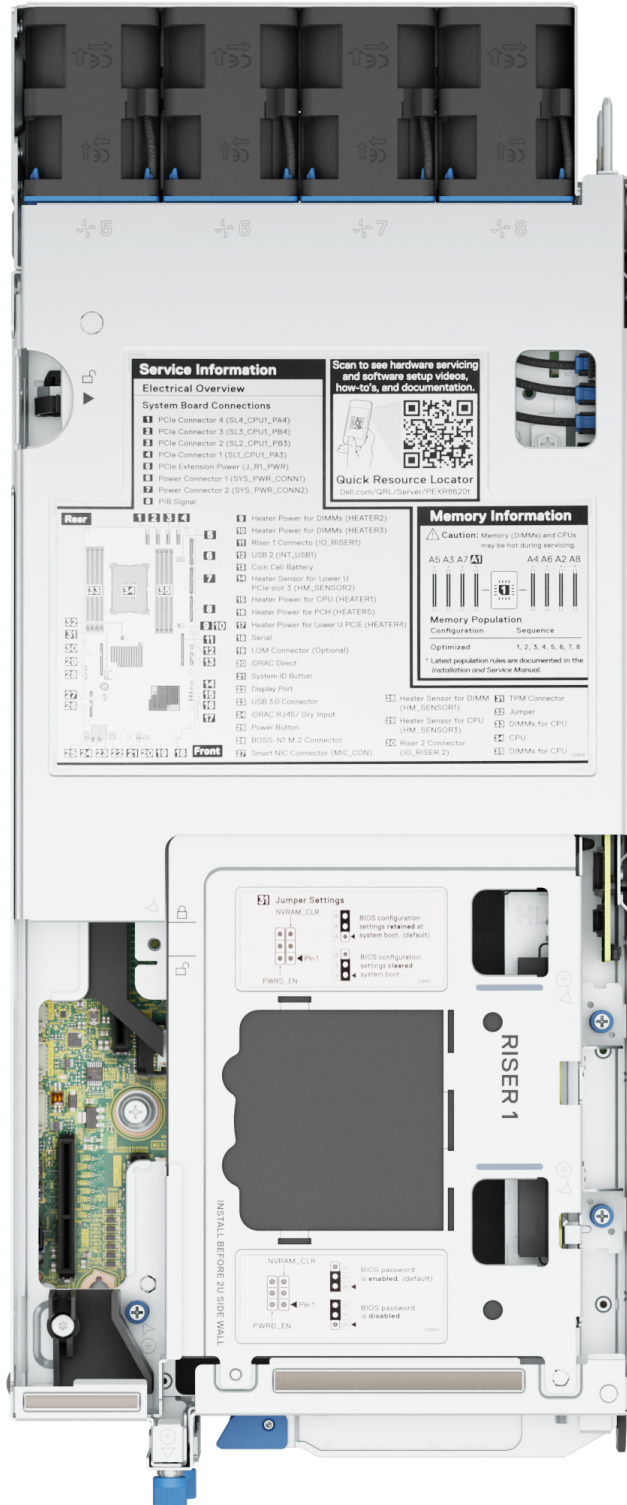

Figure 8. Inside view of 2U sled with top cover and Riser 1

Inside view with Riser 1

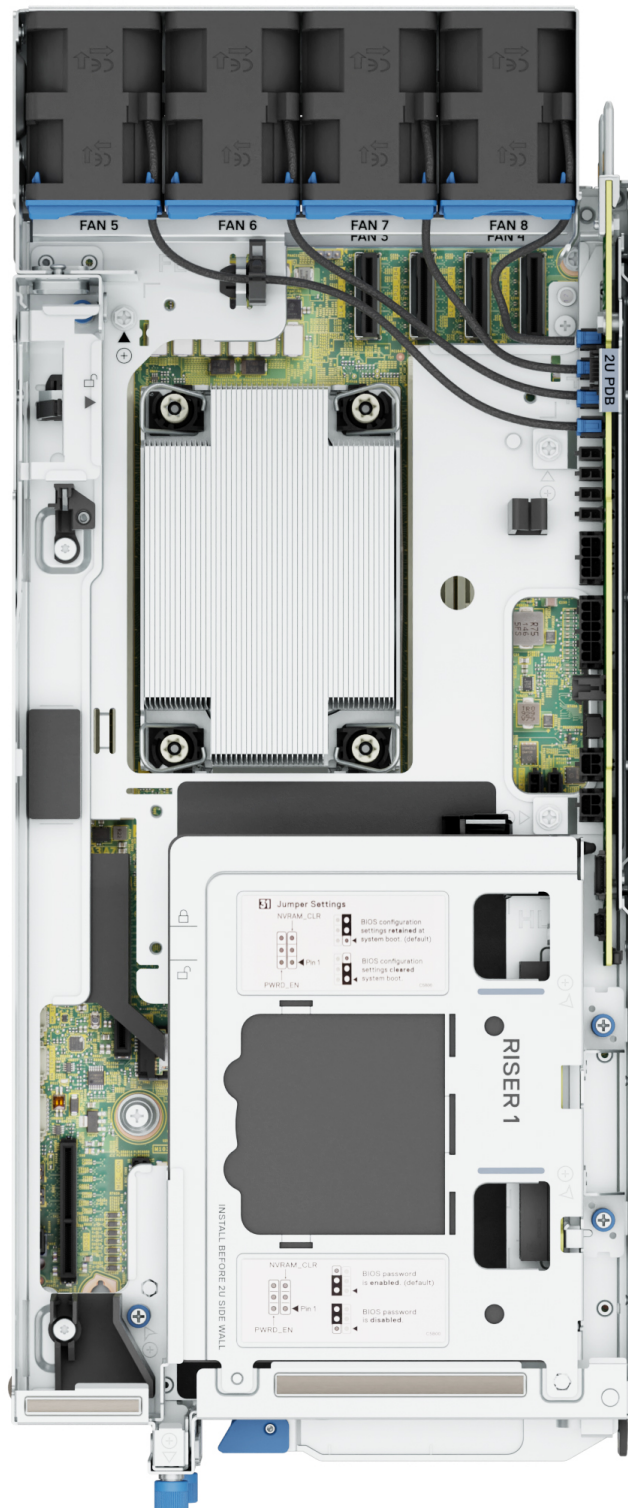

Figure 9. Inside view with Riser 1

Inside view of sled

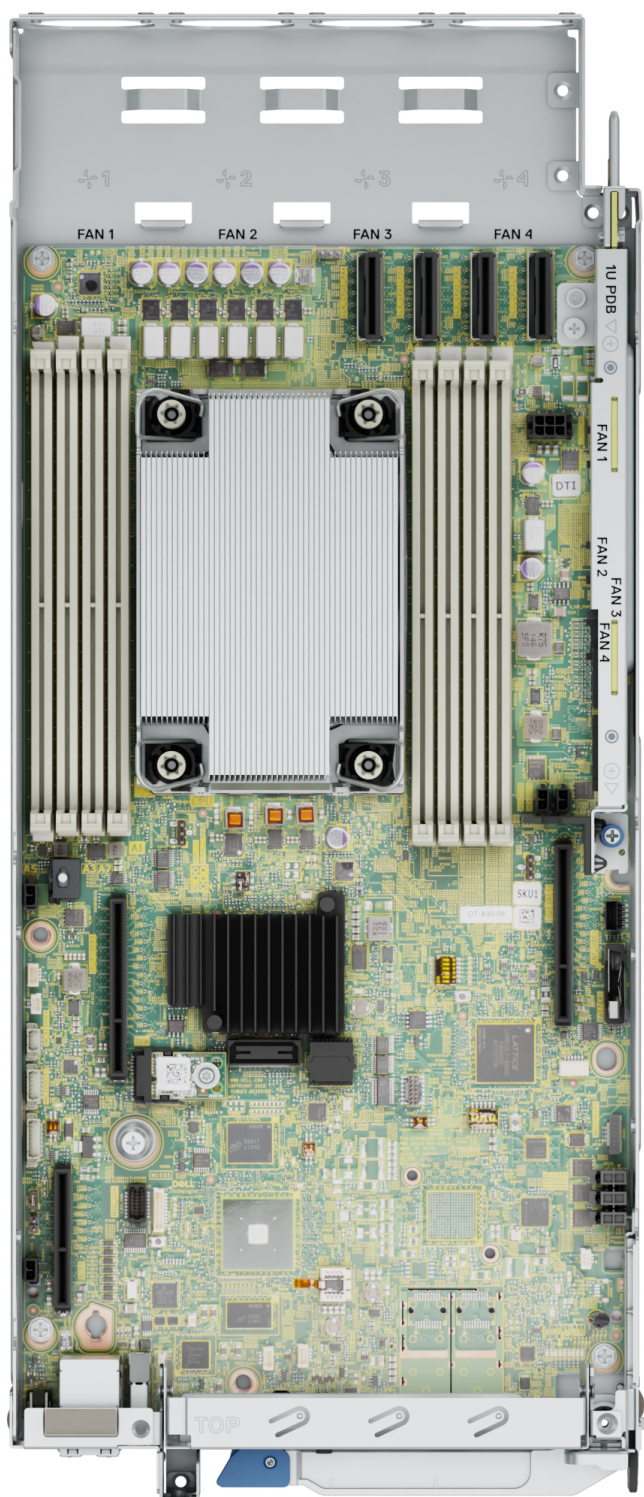

Figure 10. Inside view of sled

Processor



Topics:

- [Processor features](#)

Processor features

Technology:

- Support Intel 5th and 4th Generation Xeon Processor
- Up to 32 cores
- 10nm process technology

Memory:

- Up to 8 channels with 1 DPC, 8 DIMMs in total
- Supports RDIMM DDR5 with ECC up to 5600 MT/s

PCIe interfaces:

- Integrated PCI Express Gen 5 for improved bandwidth and connectivity
- Up to 80 lanes per CPU

Package:

- Intel socket E

The Sapphire Rapids Server core is the next generation core architecture with many improvements such as the improved Instructions per Cycle (IPC) among others. Included in the Sapphire Rapids family of processors are Integrated Memory Controllers (IMC) and an Integrated I/O (IIO) on a single silicon die. The Sapphire Rapids Server core features are as follows:

- Virtual address space of 57 bits and a physical address space of 52 bits.
- First Level Cache (FLC) is 64 KB total. It is comprised of a 32 KB ICU (Instruction Cache) and 32 KB DCU (Data Cache).
- 1.25 MB Mid-Level Cache (MLC) per core (non-inclusive with the 1.5 MB Last Level Cache).
- Intel Hyper-Threading Technology (Intel® HT Technology) when enabled allows each core to support two threads.
- Intel® Turbo Boost Technology allows the processor cores to run faster than its rated operating frequency if it is operating below power, temperature, and current limits. The result is increased performance in multi-threaded and single threaded workloads.
- Intel® Advanced Vector Extensions 512 (Intel® AVX-512) with a single AVX512 fused multiply-add (FMA) execution units. SKUs which support Advanced RAS enable a 2nd FMA execution unit.
- Intel® Virtualization Technology (Intel® VT) for Intel® 64 and IA-32 Intel® Architecture (Intel® VT-x) provides hardware acceleration for virtualization of IA platforms. Virtual Machine Monitor (VMM) can use Intel VT-x features to provide more reliable and secured virtualized platforms.
- Intel® Virtualization Technology (Intel® VT) for Directed I/O (Intel® VT-d) helps the VMM better utilize hardware to improve performance and availability of I/O devices in virtualized environment by direct assignment of devices.
- Intel® Trusted Execution Technology Architecture (Intel® TXT) defines platform level enhancements with a Trusted Platform Module (TPM) that provides the building blocks for creating trusted platforms.

Supported processors

Table 6. Supported processors

Proc	Clock Speed (GHz)	Cache (M)	UPI (GT/s)	Cores	Threads	Turbo	Memory Speed (MT/s)	Memory Capacity	CPS Enabled	TDP
6438N	2.0	60	16	32	64	Turbo	4800	4TB	N	205W
6433N	2.0	60	16	32	64	Turbo	4400	4TB	N	205W
6423N	2.0	53	16	28	56	Turbo	4400	4TB	N	195W
6421N	1.8	60	16	32	64	Turbo	4400	4TB	N	185W
6403N	1.9	45	16	24	48	Turbo	4400	4TB	N	185W
5423N	2.1	38	16	20	40	Turbo	4000	4TB	N	145W
5411N	1.9	45	16	24	48	Turbo	4400	4TB	N	165W
4514Y	2.0	30	16	16	32	Turbo	4400	4TB	N	150W
4510	2.4	30	16	12	24	Turbo	4400	4TB	N	150W
4509Y	2.6	23	16	8	16	Turbo	4400	4TB	N	125W

NOTE: It is recommended to use a maximum of two add-in cards with SPR EE-LCC CPU. Three add-in cards are supported, but this may result in an overall system performance degradation. .

Memory subsystem

Topics:

- Supported memory

Supported memory

The PowerEdge XR8610t and XR8620t supports up to 8 DIMMs, with up to 512GB of standard memory and speeds of up to 5600MT/s. In addition, the PowerEdge XR8000 supports Registered DIMMs (RDIMMs) which use a buffer to reduce memory loading and provide greater density, allowing for the maximum platform memory capacity. Unbuffered DIMMs (UDIMMs) and 3DS DIMMs are not supported.

Table 7. Memory technology

Feature	PowerEdge XR8000 (DDR5)
DIMM type	RDIMM
Transfer speed	5600 MT/s
Voltage	1.1 V (DDR5)

The following table lists the supported DIMMs for the XR8000. For the latest information about supported memory and memory configurations, reference the latest SDL.

Table 8. Supported DIMMs

DIMM PN	Rated DIMM Speed (MT/s)	DIMM Type	DIMM Capacity (GB)	Ranks per DIMM	Data Width	DIMM Volts (V)
1V1N1	4800	RDIMM	16	1	x8	1.1
W08W9	4800	RDIMM	32	2	x8	1.1
J52K5	4800	RDIMM	64	2	x4	1.1
5DR48	5600	RDIMM	16	1	x8	1.1
P8XPW	5600	RDIMM	32	2	x8	1.1
58F8N	5600	RDIMM	64	2	x4	1.1

 **NOTE:** The processor may reduce the performance of the rated DIMM speed.

Storage

Topics:

- [Supported Drives](#)

Supported Drives

The table shown below lists the internal drives supported by the XR8000. Refer to Agile for the latest SDL.

Table 9. Supported Drives

Dell PN	Description
08M01	480GB, 2280, RI (1DWPD)
H3T8R	480GB, 2280, RI (1DWPD)
31XDY	800GB, 2280, (3DWPD) - MU
GHRW8	800GB, 2280, (3DWPD) - MU
21GXV	960GB, 2280, RI (1DWPD)
PRV6C	960GB, 2280, RI (1DWPD)
HN8H6	960GB, 2280 FIPS
6WX1V	960GB, 2280 FIPS
G18YX	1.92TB, 22110, RI (1DWPD)
MY5M4	1.92TB, 22110, RI (1DWPD)
J927V	1.92TB, 22110, (1WPD)
5JR5H	3.84TB, 22110, RI
5FP33	3.84TB, 22110, RI
2RN2N	3.84TB, 22110, (1WPD)

Networking

Topics:

- [Overview](#)
- [Integrated LOM](#)

Overview

PowerEdge offers a wide variety of options to get information moving to and from our servers. Industry best technologies are chosen, and systems management features are added by our partners to firmware to tie in with iDRAC and Lifecycle Controller. These adapters are rigorously validated for worry-free, fully supported use in our servers.

Integrated LOM

The PowerEdge XR8610t and XR8620t sleds include an optional integrated 2x 25GbE SFP28 LOM. It is connected through a x8 PCIe Gen 3.0 link off of P1[7:0] from CPU. Broadcom 57414 features are:

- Two port 25Gb with SFP28 LOM (Optional) and no external timing support.
- Fully compliant with the SFF-8402 standard
- x8 PCI Express 3.0 compliant
- SR-IOV with up to 1k virtual functions (VFs)
- Function-Level Reset (FLR) support
- TruFlow™ flow processing engine
- VXLAN, NVGRE, Geneve, IP-in-IP, MPLS encap/decap
- vSwitch Acceleration
- Tunnel-aware stateless offloads
- DCB support – PFC, ETS, QCN, DCBx
- RDMA over Converged Ethernet (RoCE)
- Network Controller Sideband Interface (NC-SI)
- SMBus 2.0
- MCTP over SMBus
- Jumbo frames up to 9600-Byte
- Advanced congestion avoidance
- Multiqueue, NetQueue, and VMQueue
- IPv4 and IPv6 offloads
- TCP, UDP, and IP checksum offloads
- Generic receive offload (GRO)
- Large receive offload (LRO)
- TCP segmentation offload (TSO)
- Receive-side scaling (RSS)
- Transmit-side scaling (TSS)
- VLAN insertion/removal
- Message signal Interrupt (MSI-X)
- Network boot – PXE, UEFI
- iSCSI boot
- Wake-on-LAN (WOL).

PCIe subsystem

Topics:

- PCIe subsystem overview
- PCIe risers
- PCIe slot power
- Slot priority matrix

PCIe subsystem overview

The PowerEdge XR8000 supports 3 full height half-length x16 PCIe slots. All PCIe ports are PCIe Gen5 capable with 16 lanes per socket and 75W card's edge delivered power per slot. There are two extra power connectors for slot 1 and slot 2 that deliver an additional 75W to each slot for up to 150W per slot. A large variety of PCIe cards are supported on the XR8000.

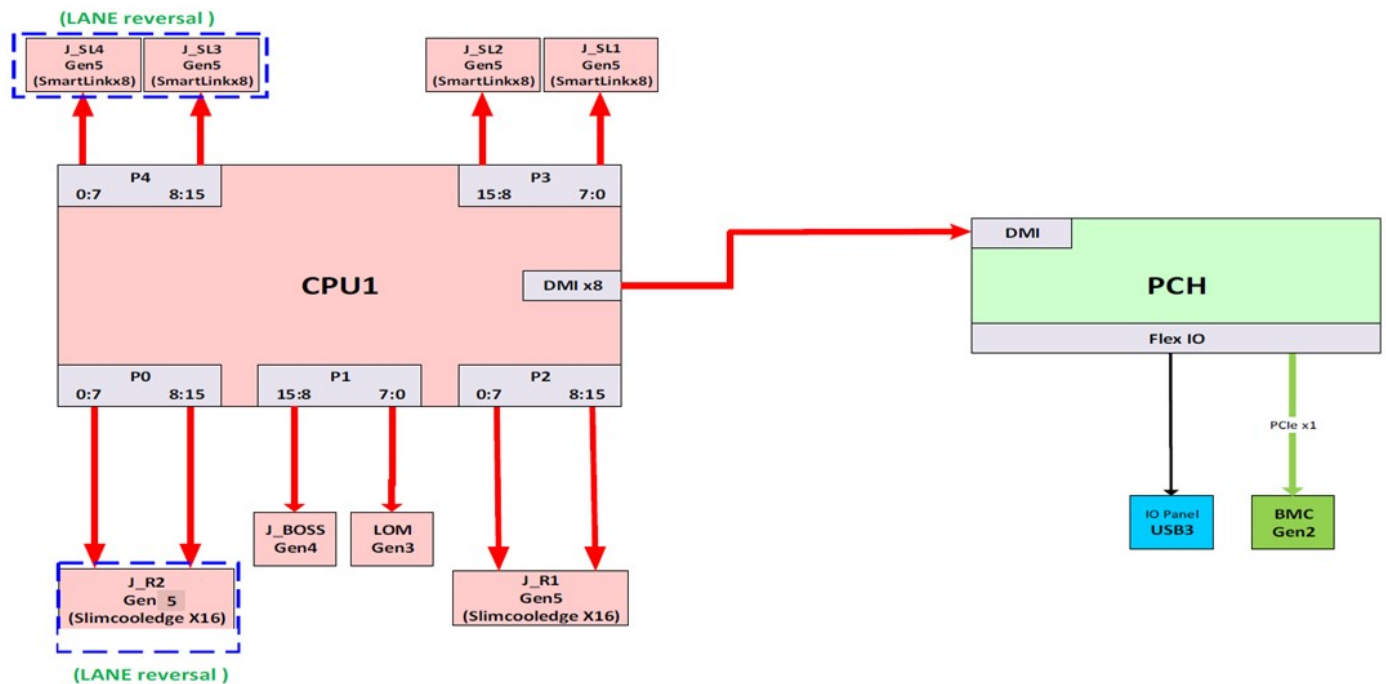

Figure 11. PCIe connection diagram

PCIe risers

The PowerEdge XR8000 does not have a “no riser” option and only supports one riser config option: Riser 1 on 1U/2U sled, Floating Riser on 2U sled. Shown below are details on the three risers supported on the PowerEdge XR8000.

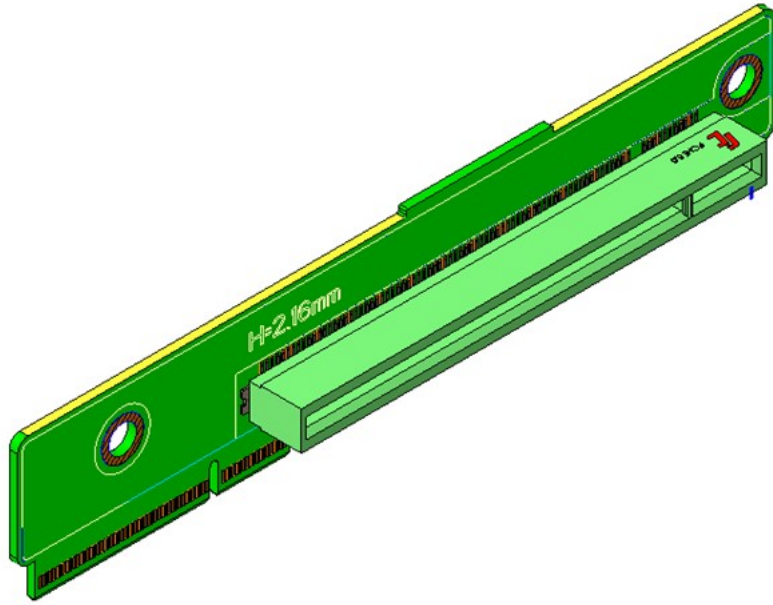

Figure 12. Riser 1

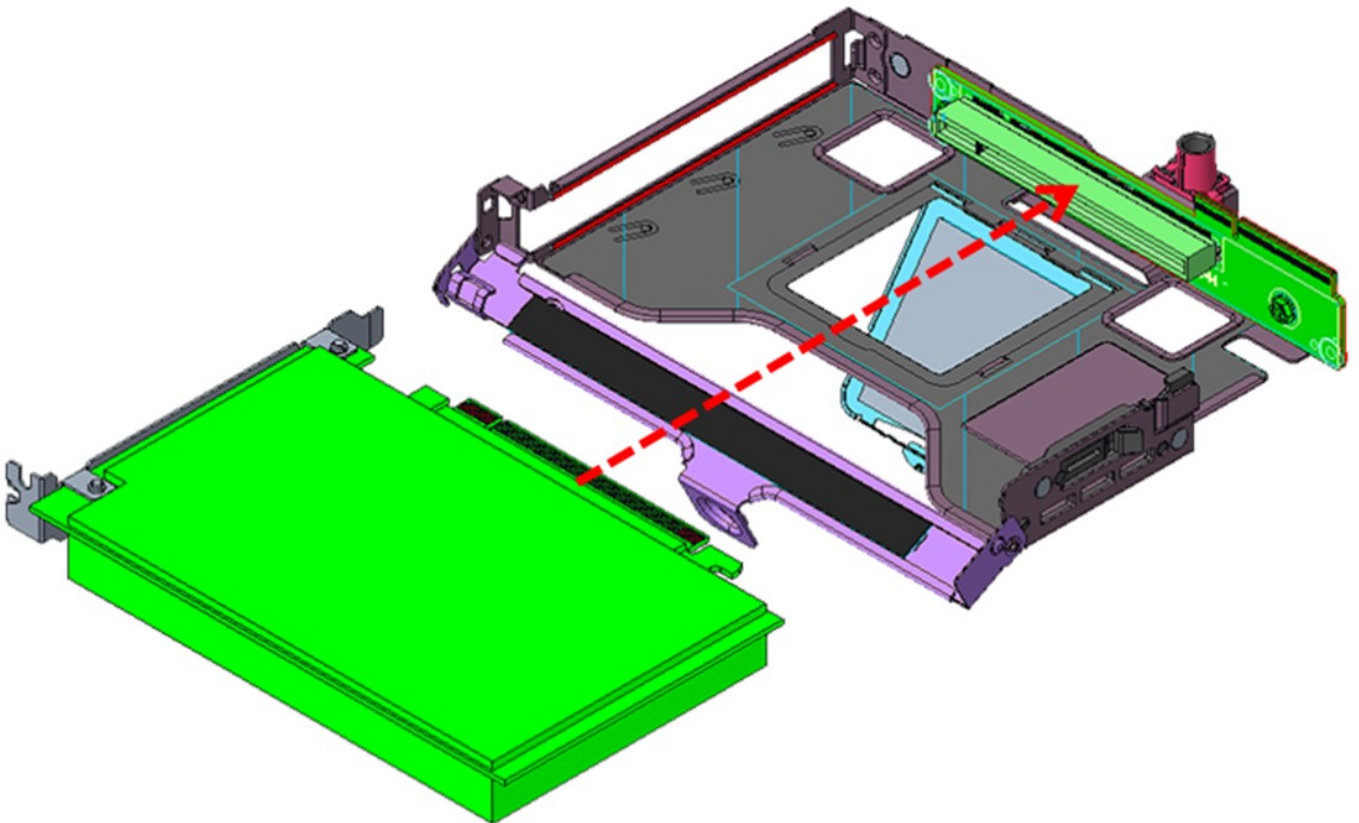

Figure 13. Riser 1 with mechanical enclosure

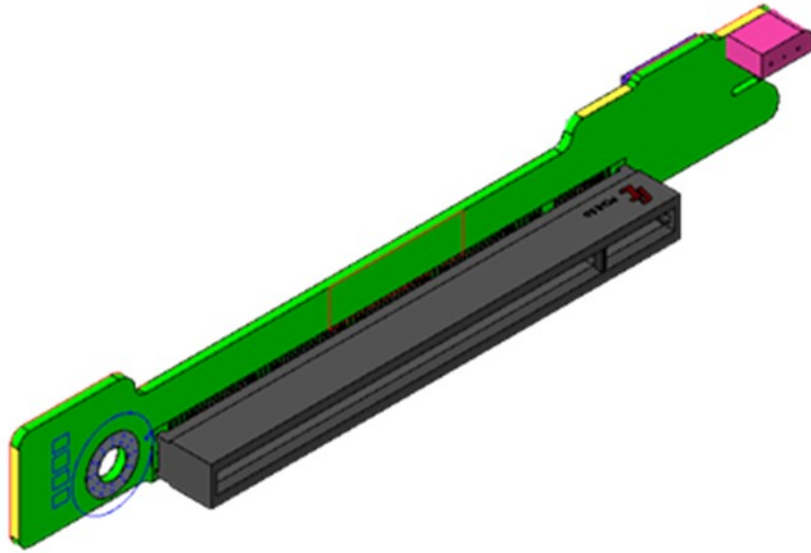

Figure 14. Floating Riser

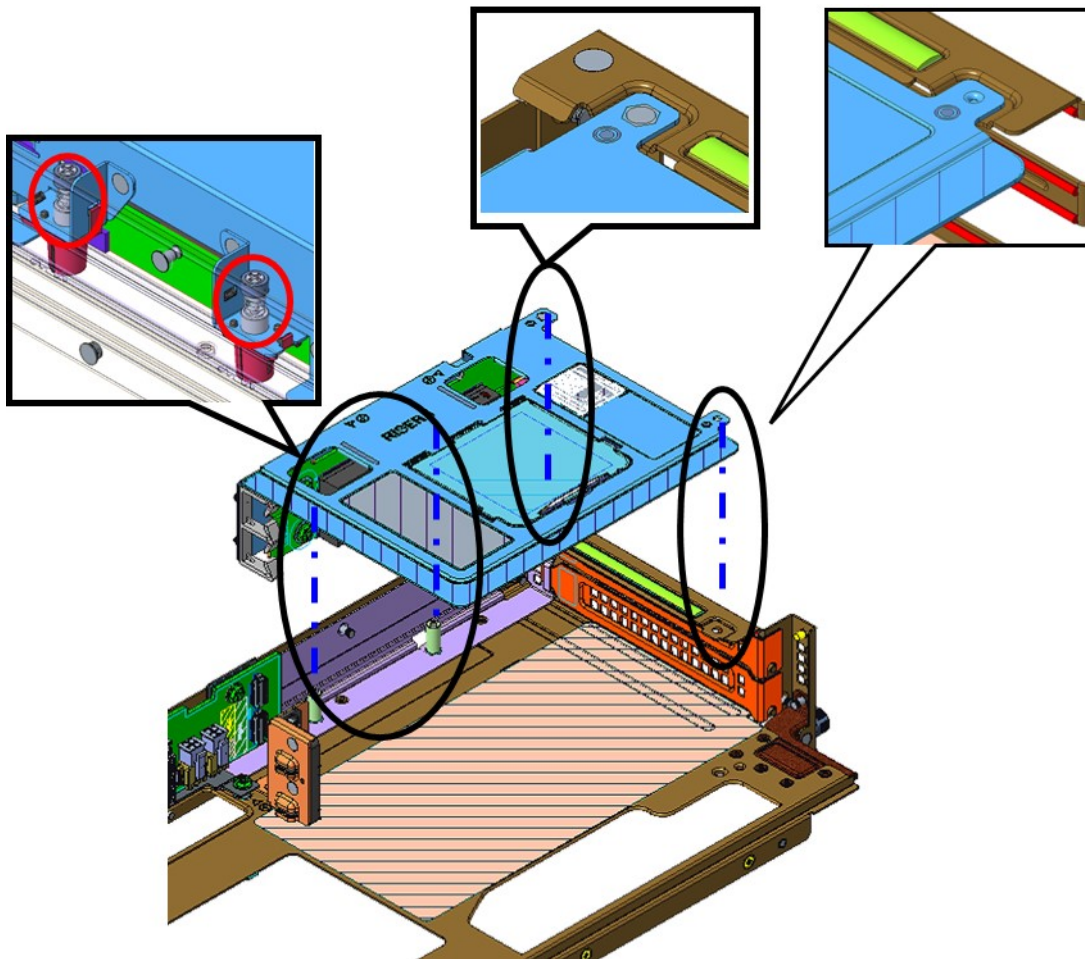

Figure 15. Floating Riser with mechanical enclosure (2U)

PCIe slot power

Table 10. PCIe slot power

PCIe Riser Slot	Max Lane Width	Card Height / Length	PCIe Slot Power Max	AUX Cable	S5 Power
Slot 1, Slot 2	x16	FHHL	75W	75W (2U PDB GPU - SIG_GPU_PWR)	No
				320W (2U PDB POUT - SIG_PWR_1)	
Slot 3	x16	FHHL	75W	75W (J6041)	Yes

SIG_GPU_PWR is a reserve power connector for GPU AUX12V. It is max power can support up to 75W. SIG_PWR_1 is a 12 pin power connector with 12V and 3.3V AUX power which can support up to 320W. Both connectors support cable present pin function.

Lower U PCIe Slot3 Nokia Aux Power Cable (KCFV2)

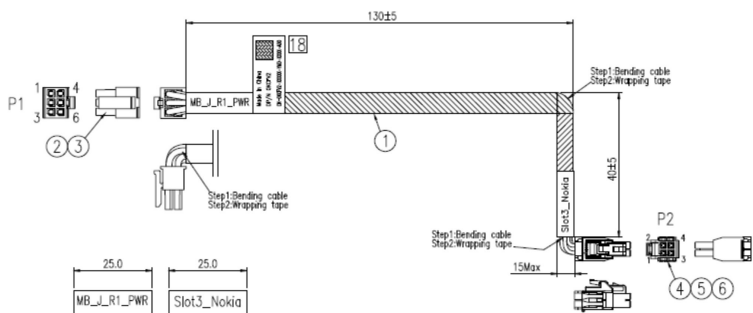

P1		P2		AWG	COLOR	CURRENT
+12V	1	3	+12V	20	YELLOW	3A
+12V	2	4	+12V	20	YELLOW	3A
+12V	3					
GND	4	1	GND	20	BLACK	
PRES	5	2	PRES	20	GRAY	
GND	6					

P1(Planar)

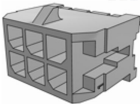

Planar Power connector
6 pin Molex 43045-0627

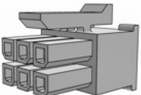

Cable connector for MB
6 pin Amphenol HH30006005

P2(L1 Card)

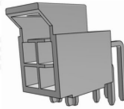

Nokia L1 Aux Power connector
4 pin Molex 105314-1304

L1 Connector Pin definition
GND : pin1/2
12V : Pin3/4



Cable connector for PCIe
4 pin Molex 105308-1204

Figure 16. Lower U PCIe Slot3 Nokia Aux Power Cable (KCFV2)

Lower U PCIE Slot3 Cable Present Pin

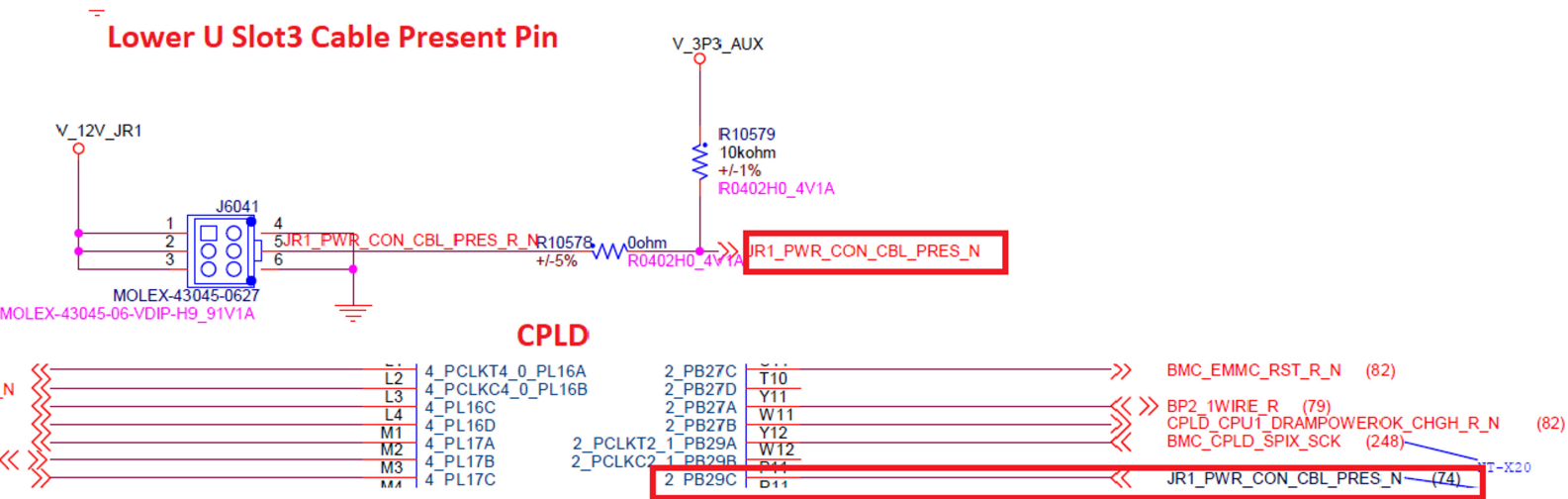

Figure 17. Lower U PCIE Slot3 Cable Present Pin

Upper U PCIE Slot1&2 Nokia Aux Y Power Cable (W0RX0)

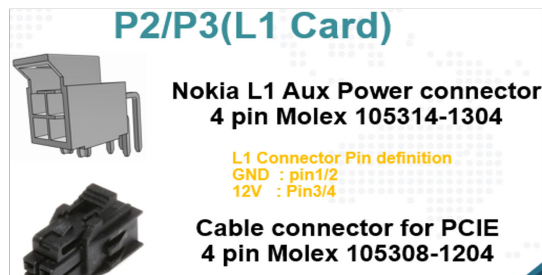
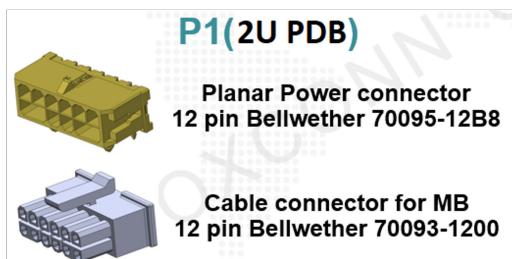
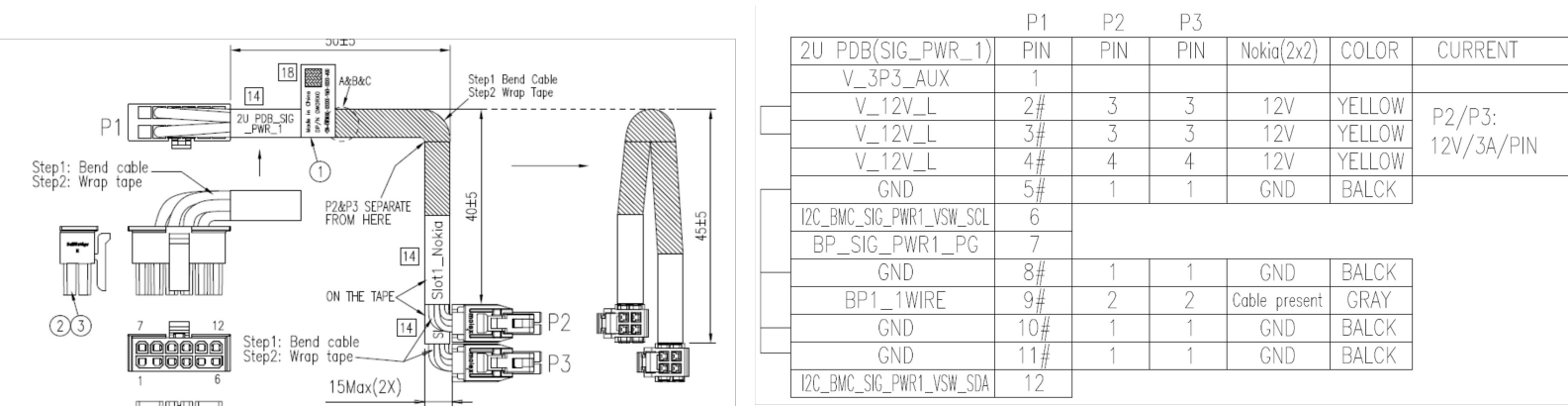

Figure 18. Upper U PCIE Slot1&2 Nokia Aux Y Power Cable (W0RX0)

Upper U PCIE Slot1 & 2 Y Cable Present Pin



2U PDB

Silkscreen: SIG_PWR_1

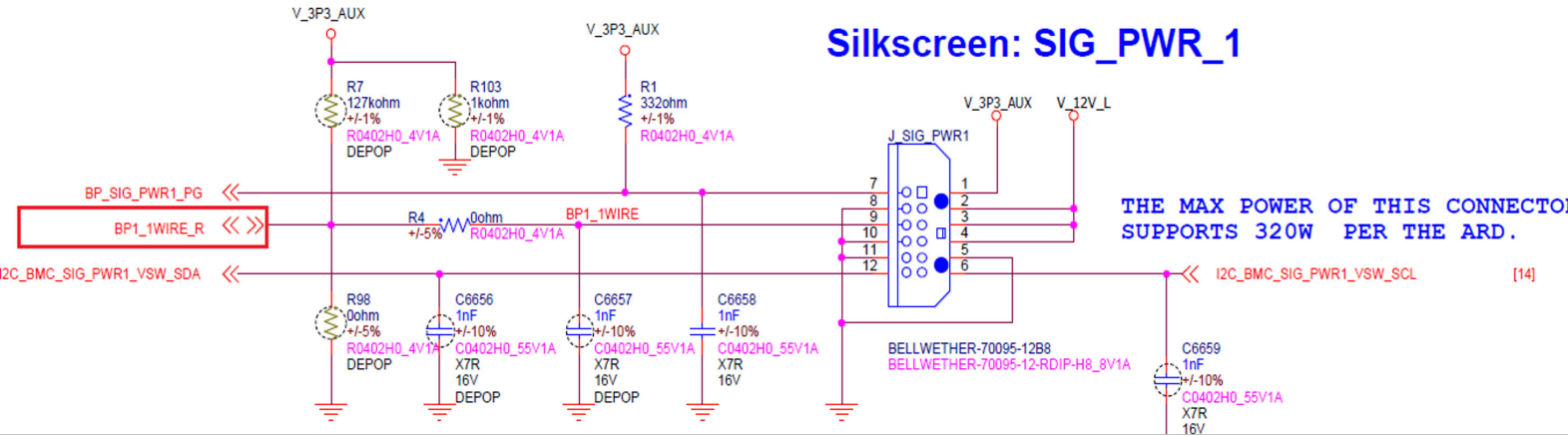

CPLD

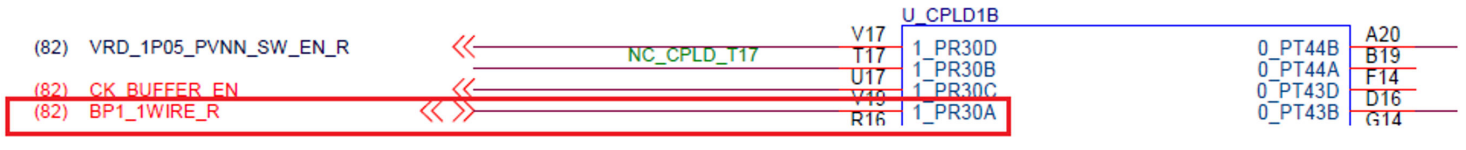

Figure 19. Upper U PCIE Slot1 & 2 Y Cable Present Pin

Present Ping Register / SPIX Map: Offset 100, Bit [1:0])

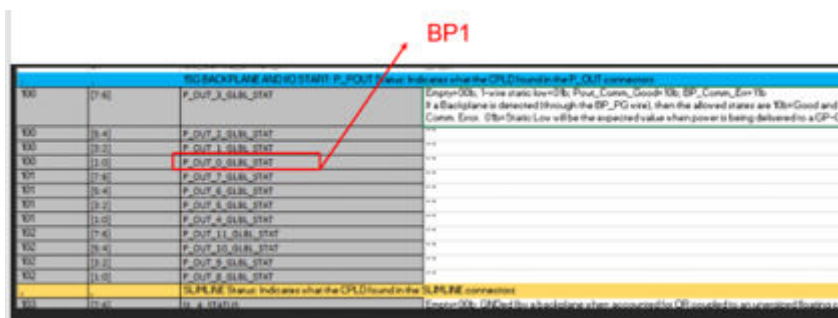

Figure 20. Present Ping Register / SPIX Map: Offset 100, Bit [1:0])

Slot priority matrix

For add-in cards that can be mapped to the XR8000 and guidelines for installing expansion cards, see the XR8000 slot priority matrix file on Sales Portal.

Link: Sales Portal

Expansion card installation guidelines

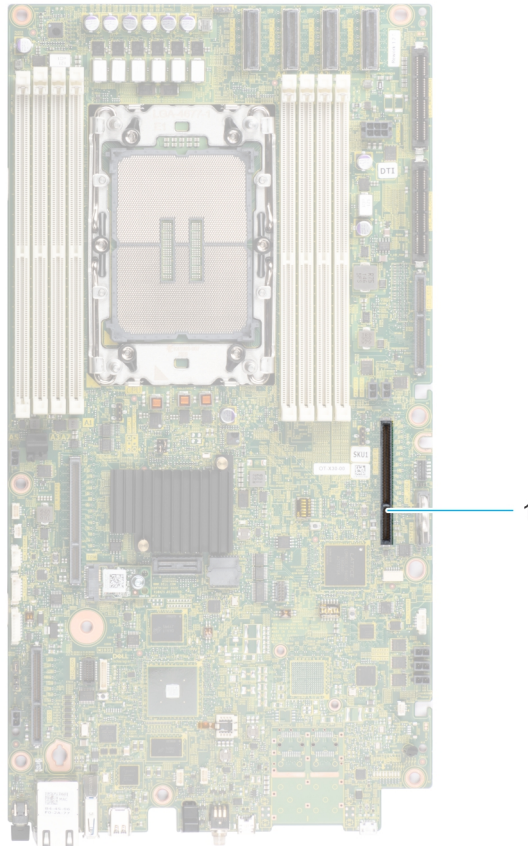

Figure 21. Expansion card slot connector

1. Riser connector (Riser 2)

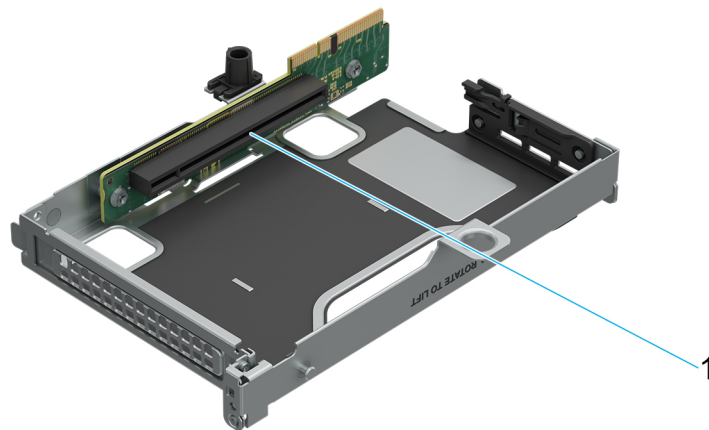



Figure 22. Riser 2A slot

1. Slot 1

Table 11. Riser Configurations

Config	Riser Configuration	CPUs	PERC type supported	Rear storage	x16 CPU1	X16 CPU2
0	No riser	1	No	No	0	0
1	R2A	1	No	No	1	0

 **NOTE:** The expansion-card slots are not hot-swappable.

The following table provides guidelines for installing expansion cards to ensure proper cooling and mechanical fit. The expansion cards with the highest priority should be installed first using the slot priority indicated. All the other expansion cards should be installed in the card priority and slot priority order.

Table 12. Configuration 0: No Riser

Card type	Slot priority	Maximum number of cards
BOSS-N1	Integrated slot	1
Dual M.2 riser	Integrated slot	1
Single M.2 riser	Integrated slot	1

Table 13. Configuration 1: R2A

Card type	Slot priority	Maximum number of cards
INTEL (NIC: 25 GB, FH, adapter)	1	1
INTEL (NIC: 100 GB, FH, adapter)	1	1
INTEL(NIC: ACC100, FH, adapter)	1	1
Mellanox (NIC: 100 GB, FH)	1	1
Dell (Interface, PCIE: 3.0)	1	1
Nokia (NIC: 100 GB, FH)	1	1
Qualcomm (NIC: 100 GB, FH)	1	1
BOSS-N1	Integrated slot	1
Dual M.2 riser	Integrated slot	1
Single M.2 riser	Integrated slot	1

Expansion card installation guidelines

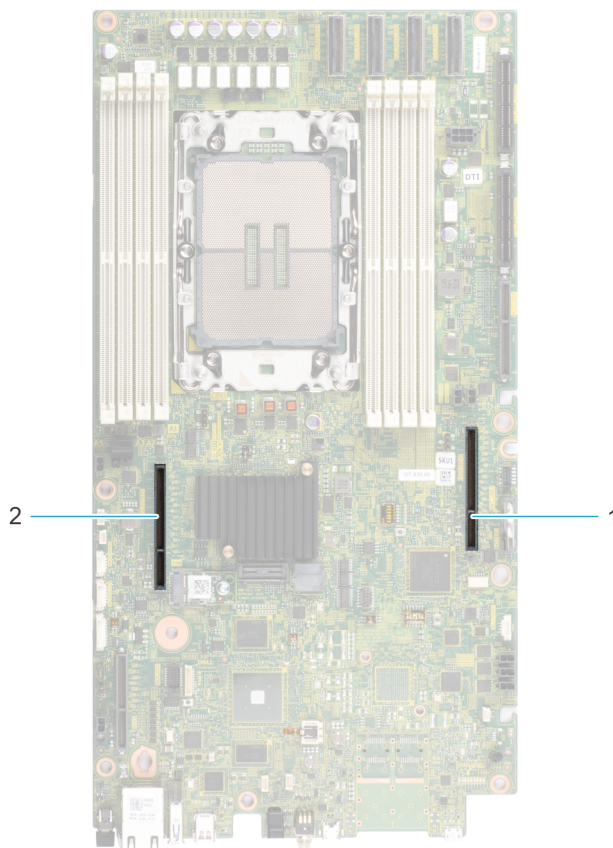

Figure 23. Expansion card slot connector

1. Riser 1U connector(Riser 2)
2. Single M.2 riser connector (IO_RISER2)

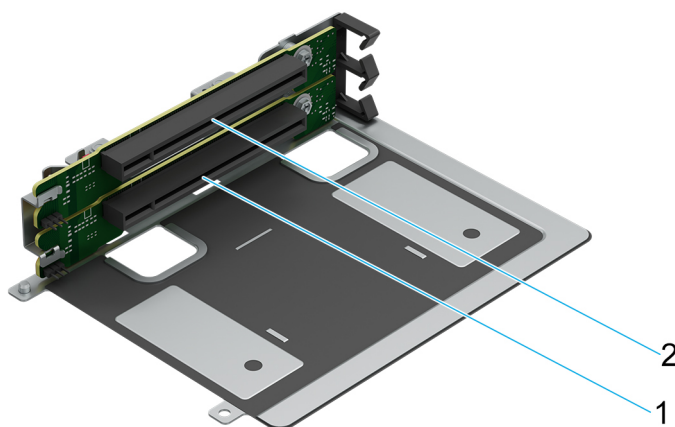

Figure 24. Riser 1A slots

1. Slot 1
2. Slot 2

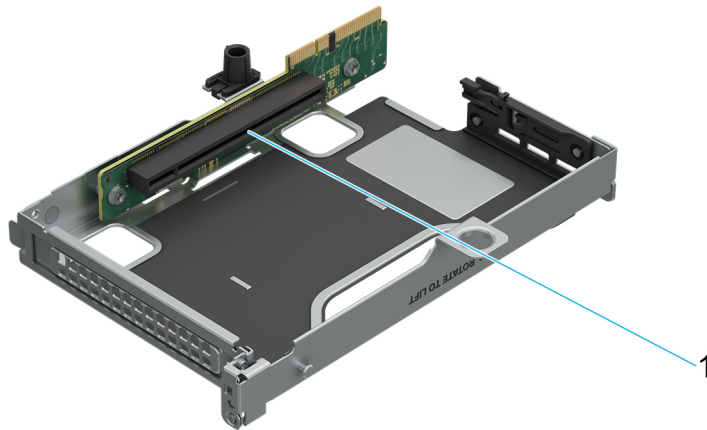

Figure 25. Riser 2A slot

1. Slot 3

Table 14. Riser Configurations

Config #	RSR Configuration	# of CPUs	PERC type supported	Rear Storage Possible	x16 CPU1	X16 CPU2
0	No riser	1	No	No	0	0
1	R1A+R2A	1	No	No	3	0

NOTE: The expansion-card slots are not hot-swappable.

The following table provides guidelines for installing expansion cards to ensure proper cooling and mechanical fit. The expansion cards with the highest priority should be installed first using the slot priority indicated. All the other expansion cards should be installed in the card priority and slot priority order.

Table 15. Configuration 0: No Riser

Card type	Slot priority	Maximum number of cards
Single M.2 Riser	Integrated slot	1
M.2 NVMe Riser HW Non-RAID	Integrated slot	1
ROR-N1	Integrated slot	1
M.2 NVMe Riser HW Non-RAID HM	Integrated slot	1
ROR-N1 HM	Integrated slot	1

Table 16. Configuration 1: R1A_HL+R2A

Card type	Slot priority	Maximum number of cards
INTEL (NIC: 25GB, FH, adapter)	3, 2, 1	3
INTEL (NIC: 100GB, FH, adapter)	3, 2, 1	3
INTEL (NIC: 100GB, FH, adapter)	3,1	2
DELL (PCIe: INTFC, 3.0, FH)	1, 2	2
NOKIA (NIC:100GB, FH)	1, 2	2
QUALCOMM (NIC: 100GB, FH)	1, 2, 3	3
INTEL(NIC: MacLaren, FH, adapter)	3, 2, 1	1

Table 16. Configuration 1: R1A_HL+R2A (continued)

Card type	Slot priority	Maximum number of cards
Mellanox (NIC: 100GB, FH, adapter)	3, 2, 1	3
NVIDIA (GPU: L4, 24GB, FH)	3, 2, 1	1
M.2 NVMe Riser HW Non-RAID	Integrated slot	1
BOSS-N1	Integrated slot	1
ROR-N1	Integrated slot	1
Single M.2 Riser	Integrated slot	1

Table 17. Configuration 5_Config1 wHM

Card type	Slot priority	Maximum number of cards
INTEL (NIC: 25GB, FH, adapter)	3, 2, 1	3
INTEL (NIC: 100GB, FH, adapter)	3, 2, 1	3
INTEL(NIC: MacLaren, FH, adapter)	3, 2, 1	1
M.2 NVMe Riser HW Non-RAID HM	Integrated slot	1
FOXCONN ROR-N1 HM	Integrated slot	1

Power, thermal, and acoustics

PowerEdge servers have an extensive collection of sensors that automatically track thermal activity, which helps regulate temperature thereby reducing server noise and power consumption. The table below lists the tools and technologies Dell offers to lower power consumption and increase energy efficiency.

Topics:

- [Power](#)
- [Thermal](#)
- [PowerEdge XR8000 acoustics](#)

Power

Table 18. Power tools and technologies

Feature	Description
Power Supply Units(PSU) portfolio	Dell's PSU portfolio includes intelligent features such as dynamically optimizing efficiency while maintaining availability and redundancy. Find additional information in the Power supply units section.
Tools for right sizing	Enterprise Infrastructure Planning Tool (EIPT) is a tool that can help you determine the most efficient configuration possible. With Dell's EIPT, you can calculate the power consumption of your hardware, power infrastructure, and storage at a given workload. Learn more at Dell EIPT .
Industry Compliance	Dell's servers are compliant with all relevant industry certifications and guide lines, including 80 PLUS, Climate Savers and ENERGY STAR.
Power monitoring accuracy	PSU power monitoring improvements include: <ul style="list-style-type: none"> • Dell's power monitoring accuracy is currently 1%, whereas the industry standard is 5%. • More accurate reporting of power • Better performance under a power cap
Power capping	Use Dell's systems management to set the power cap limit for your systems to limit the output of a PSU and reduce system power consumption. Dell is the first hardware vendor to leverage Intel Node Manager for circuit-breaker fast capping.
Systems Management	iDRAC Enterprise and Datacenter provides server-level management that monitors, reports and controls power consumption at the processor, memory and system level. Dell OpenManage Power Center delivers group power management at the rack, row, and data center level for servers, power distribution units, and uninterruptible power supplies.
Active power management	Intel Node Manager is an embedded technology that provides individual server-level power reporting and power limiting functionality. Dell offers a complete power management solution comprised of Intel Node Manager accessed through Dell iDRAC9 Datacenter and OpenManage Power Center that allows policy-based management of power and thermal at the individual server, rack, and data center level. Hot spare reduces power consumption of redundant power supplies. Thermal control off a speed optimizes the thermal settings for your environment to reduce fan consumption and lower system power consumption. Idle power enables Dell servers to run as efficiently when idle as when at full workload.
Fresh Air cooling	See ASHRAE A3/A4 Thermal Restriction.

Table 18. Power tools and technologies (continued)

Feature	Description
Rack infrastructure	<p>Dell offers some of the industry's highest-efficiency power infrastructure solutions, including:</p> <ul style="list-style-type: none"> • Power distribution units (PDUs) • Uninterruptible power supplies (UPSs) • Energy Smart containment rack enclosures <p>Find additional information at: Power and Cooling.</p>

Power Supply Units

Energy Smart power supplies have intelligent features, such as the ability to dynamically optimize efficiency while maintaining availability and redundancy. Also featured are enhanced power-consumption reduction technologies, such as high-efficiency power conversion and advanced thermal-management techniques, and embedded power-management features, including high-accuracy power monitoring. The table below shows the power supply unit options that are available for the XR8000.

Table 19. Power Supply Unit Options

Wattage	Frequency	Voltage/Current	Class	Heat dissipation
800W -48VDC	N/A	-48--60Vdc/20A	N/A	3208 BTU/hr
1100W -48VDC	N/A	-48--60Vdc/27A	N/A	4265 BTU/hr
1400W -48VDC	N/A	-48--60Vdc/33.5A	N/A	5310 BTU/hr
1400 W mixed mode	50/60 Hz	100–240 Vac/12—8 A	Platinum	5250 BTU/hr
	N/A	240 Vdc/6.6 A	N/A	5250 BTU/hr
1800 W mixed mode	50/60 Hz	200–240 Vac/10 A	Titanium	6750 BTU/hr
	N/A	240 Vdc/8.2 A	N/A	6750 BTU/hr

 **NOTE:** All PSU come in Reverse Airflow offerings (Reverse Airflow PSUs).

 **NOTE:** If a system with AC 1400 W MM PSUs operates at low line 100-120 Vac, and then the power rating per PSU is degraded to 1050 W.

Cable Routing Procedure

Introduction

This section covers recommended cable routing procedures for the Dell PowerEdge XR8000 installed in standard 19" rack enclosures and in cell site cabinets. XR8000 with its unique chassis design is being positioned for both CRAN and DRAN deployments along with some specific Telco Core use cases. This extends the deployment capability of XR8000 far more than the mainstream Rack Servers. One important point to note that XR8000 for Telco deployment utilizes the Front I/O based sled and there is no provision of using cable management arm (CMA) as in Mainstream Rack based servers.

The importance of the cable routing procedure in XR8000 is important as cable management plays a very important role in the serviceability and ease of maintenance of any telco grade Hardware. Where downtime means loss of revenue and in accessibility to emergency services a proper routing guideline goes a long way to secure customer satisfaction and experience.

XR8000 General Recommendation during installation:

- Guidance for keeping space at the front of the Chassis:** XR8000 needs a minimum of 30.4mm between the front of the system and the front edge of the cabinet door.
- Guidance for keeping space at the rear end of the chassis:** Rear exhaust plenum should be a minimum of 50mm for ambient temperatures up to 55C. For ambient temperatures from 55C to 65C a plenum of 55mm should be provided

- 3. Airflow:** XR8000 has an airflow from front of the chassis to the rear. In a closed cabinet it is recommended to have a conditioned air to flow inside the cabinet.
- 4. Air Filtration:** The XR8k does not come with air filtration bezel. It is recommended to have air filtration performed at the cabinet level. It is also important to note that the XR8000 is not a sealed chassis. The implication is that small animals can take nest in the unit's various cavities.

Useful References:

- XR8000 Rack Rail Install Guide: [Rail Installation Guide B31 Rails](#)
- XR8000 Installation and Service Manual: [Dell PowerEdge XR8000r Installation and Service Manual](#)
- XR8000 Regulatory and Environmental Datasheet: [Product Compliance Datasheet](#)
- Cabling Instructions for -48V DC Supply: [Cabling-instructions-for--48-to--60-DC-power-supply](#)
- Troubleshooting guide for power supplies: [Dell PowerEdge: Power Supply Units \(PSU\) Tutorial | Dell US](#)

Recommendation of Space Required for Installing an XR8000 for proper airflow

Section 1: Cabling a PowerEdge XR8000 installed in a two-post cabinet

This section details how to cable the PowerEdge XR8000 installed in a two-post cabinet.

About this task

First note that there are a couple of options for rack install:

- Flush mount (where the face of the chassis is flush with the post)
- Center mount (where the posts are at the center point of the unit)

Steps

1. Install the B31 rack rails per the install guide here: [Rail Installation Guide B31 Rails](#) .
2. Install the chassis onto the rails.
3. Insert sleds into the chassis.
4. Connect power to the power supplies and make sure that the power cables are strain relieved during installation. If DC power, follow instructions here: [Cabling-instructions-for--48-to--60-DC-power-supply](#)
5. Power supplies come with a strain relief Velcro tie. Use this tie to support the power cable. The power cable should be routed to the nearest rack post or cabinet feature.
6. Rear exhaust plenum should be a minimum of 50mm for ambient temperatures up to 55C. For ambient temperatures from 55C to 65C a plenum of 55mm should be provided.
7. Using hook and loop straps bundle the signal cables coming from the sleds. If the cable management ear (CME) is utilized, cables should be routed to the nearest CME and then onto the nearest pole for retention. If the CME is not used, then please route the cables to the nearest tie point.
8. Care should be taken during routing so that no signal cables connected to the network cards need to be removed during any repair and restore activities of the PSU.
9. While the cables used will define the bend radius, the system needs a minimum of 30.4mm between the front of the system and the front edge of the cabinet door.

Section 2: Cabling a PowerEdge XR8000 installed on static rails on a four-post cabinet

This section details how to cable the PowerEdge XR8000 installed on static rails on a four-post cabinet:

Steps

1. The B31 rails support a depth of between 300 mm to 500 mm. Any four-post rack over this limit will not work with the B31 rails.
2. Install the B31 rack rails per the install guide here: [Rail Installation Guide B31 Rails](#) .
3. Install the chassis onto the rails.
4. Insert sleds into the chassis.

5. Connect power to the power supplies and make sure that the power cables are strain relieved during installation. If DC power, follow instructions here: [Cabling-instructions-for--48-to--60-DC-power-supply](#)
6. Power supplies come with a strain relief Velcro tie. Use this tie to support the power cable. The power cable should be routed to the nearest rack post or cabinet feature.
7. Rear exhaust plenum should be a minimum of 50mm for ambient temperatures up to 55C. For ambient temperatures from 55C to 65C a plenum of 55mm should be provided.
8. Using hook and loop straps bundle the signal cables coming from the sleds. If the cable management ear (CME) is utilized, cables should be routed to the nearest CME and then onto the nearest pole for retention. If the CME is not used, then please route the cables to the nearest tie point.
9. Proper care should be taken so that signal cables are not tightly fixed and have sufficient loops to move them around the ears.
10. Care should be taken during routing so that no signal cables connected to the network cards need to be removed during any repair and restore activities of the PSU.
11. While the cables used will define the bend radius, the system needs a minimum of 30.4mm between the front of the system and the front edge of the cabinet door.

Section 3: Cabling a PowerEdge XR8000 installed on static rails on a Cell Site Telecom Cabinet

Installing and cabling a XR8000 in a cell site cabinet will be a completely different process in contrast to installing and cabling in a 19" cabinet at Data Center. There can be two scenarios in which XR8000 will be deployed in a Telco environment.

Steps

1. Installing a XR8000 in a new cabinet. --- Empty Cabinet and XR8000 is the first hw going to be installed
2. Installing a XR8000 in an already existing cabinet with existing Telco hardware. - Old cabinet carrying Live HW and an XR8000 is going to be installed in it.

Section 3.A: Cabling Procedure in XR8000 in a new cabinet

Steps

1. Insert the Chassis into the cabinet.
2. Connect power to the power supplies and make sure that the power cables are strain relieved during installation. If DC power, follow instructions here: [Cabling-instructions-for--48-to--60-DC-power-supply](#)
3. Power supplies come with a strain relief Velcro tie. Use this tie to support the power cable. The power cable should be routed to the nearest rack post or cabinet feature.
4. Rear exhaust plenum should be a minimum of 50mm for ambient temperatures up to 55C. For ambient temperatures from 55C to 65C a plenum of 55mm should be provided.
5. Using hook and loop straps bundle the signal cables coming from the sleds. If the cable management ear (CME) is utilized, cables should be routed to the nearest CME and then onto the nearest pole for retention. If the CME is not used, then please route the cables to the nearest tie point.
6. Proper care should be taken so that signal cables are not tightly fixed and have sufficient loops to move them around the ears.
7. Care should be taken during routing so that no signal cables connected to the network cards need to be removed during any repair and restore activities of the PSU.
8. While the cables used will define the bend radius, the system needs a minimum of 30.4mm between the front of the system and the front edge of the cabinet door.
9. It is important to ensure the cabinet provides sufficient air filtering for XR8000 unit.

Section 3.B: Cabling Procedure in XR8000 in a existing cabinet

Steps

1. Insert the Chassis into the cabinet. Ensure none of the existing equipment is bothered.
2. Connect power to the power supplies and make sure that the power cables are strain relieved during installation. If DC power, follow instructions here: [Cabling-instructions-for--48-to--60-DC-power-supply](#)

3. Power supplies come with a strain relief Velcro tie. Use this tie to support the power cable. The power cable should be routed to the nearest rack post or cabinet feature.
4. Rear exhaust plenum should be a minimum of 50mm for ambient temperatures up to 55C. For ambient temperatures from 55C to 65C a plenum of 55mm should be provided.
5. Using hook and loop straps bundle the signal cables coming from the sleds. If the cable management ear (CME) is utilized, cables should be routed to the nearest CME and then onto the nearest pole for retention. If the CME is not used, then please route the cables to the nearest tie point.
6. Proper care should be taken so that signal cables are not tightly fixed and have sufficient loops to move them around the ears.
7. Care should be taken during routing so that no signal cables connected to the network cards need to be removed during any repair and restore activities of the PSU.
8. While the cables used will define the bend radius, the system needs a minimum of 30.4mm between the front of the system and the front edge of the cabinet door.
9. It is important to ensure the cabinet provides sufficient air filtering for XR8000 unit.

Thermal

Thermal management of the platform helps delivers high performance for the right amount of cooling to components at the lowest fan speeds across a wide range of ambient temperatures from -5°C to 55°C (23°F to 131°F) and to extended ambient temperature range from -20°C to 65°C (see [Environmental Specifications](#)). It might be reflected in lower overall power consumption (fans, platform, cooling/heating, data center power consumption, etc.) and greater acoustical versatility. PowerEdge servers have an extensive collection of sensors that automatically track thermal activity, which helps regulate temperature thereby reducing server noise and power consumption.

XR8000 Thermal Restrictions

The XR8610t and XR8620t support all standard configurations for continuous operation from +5°C to 35°C to meet ASHRAE standard A2 and from -5°C to 55°C to meet NEBS 3. In addition, the 2U node XR8620t will also support an extended operating temperature from -20°C to 65°C to meet GR3108. All configurations that are supported at the thermal limits of 55°C and 65°C are subject to restrictions.

Multi Vector Cooling

An iDRAC feature in XR8000 detects Dell PCIe cards and automatically delivers the correct airflow to the slot to cool that card. When non-Dell PCIe cards are detected, the customer is given the option to enter the airflow (LFM – Linear Feet per Minute) requirement specified by the card manufacturer. iDRAC and the fan algorithm ‘learn’ this information and the card is automatically cooled with the proper airflow.

This feature saves power by not having to run the fans to cool the worst-case card in the system. Noise is also reduced.

Environmental specifications

The PowerEdge XR8000r operates in these environmental categories: ASHRAE A2, NEBS3, GR3108C1+, GR3108C1-L, and NEBS3-H.

 **NOTE:** For additional information about environmental certifications, see the Product Environmental Datasheet located with the Documentation > Regulatory Information on [Dell Support](#).

Table 20. Continuous operation specifications for ASHRAE A2

Feature	Allowable continuous operations
Temperature range for altitudes <= 900 m (<= 2953 ft)	10–35°C (50–95°F) with no direct sunlight on the equipment
Humidity percent range (non-condensing at all times)	8% RH with -12°C minimum dew point to 80% RH with 21°C (69.8°F) maximum dew point

Table 20. Continuous operation specifications for ASHRAE A2 (continued)

Feature	Allowable continuous operations
Operational altitude de-rating	Maximum temperature is reduced by 1°C/300 m (1.8°F/984 Ft) above 900 m (2953 Ft)

Table 21. Continuous operation specifications for NEBS3

Feature	Allowable continuous operations
Temperature range for altitudes <= 900 m (<= 2953 ft)	-5° to 55°C (23 °F–131°F) with no direct sunlight on the equipment
Humidity percent range (non-condensing at all times)	8% RH with -12°C minimum dew point to 90% RH with 24°C (75.2°F) maximum dew point
Operational altitude de-rating	Maximum temperature is reduced by 1°C/80 m (1.8°F/263 Ft) above 900 m (2953 Ft)

Table 22. Continuous operation specifications for GR3108C1+

Feature	Allowable continuous operations
Temperature range for altitudes <= 900 m (<= 2953 ft)	-20° to 65°C (-4°F to 149°F) with no direct sunlight on the equipment. Cold boot support at - 20°C
Humidity percent range (non-condensing at all times)	8% RH with -12°C minimum dew point to 90% RH with 24°C (75.2°F) maximum dew point
Operational altitude de-rating	Maximum temperature is reduced by 1°C/58 m (1.8°F/190 Ft) above 900 m (2953 Ft)

Table 23. Continuous operation specifications for GR3108C1-L

Feature	Allowable continuous operations
Temperature range for altitudes <= 900 m (<= 2953 ft)	-20° to 55°C (-4°F to 131°F) with no direct sunlight on the equipment. Cold boot support at - 20°C
Humidity percent range (non-condensing at all times)	8% RH with -12°C minimum dew point to 90% RH with 24°C (75.2°F) maximum dew point
Operational altitude de-rating	Maximum temperature is reduced by 1°C/80 m (1.8°F/263 Ft) above 900 m (2953 Ft)

Table 24. Continuous operation specifications for NEBS3-H

Feature	Allowable continuous operations
Temperature range for altitudes <= 900 m (<= 2953 ft)	-5° to 65°C (23 °F–149°F) with no direct sunlight on the equipment
Humidity percent range (non-condensing at all times)	8% RH with -12°C minimum dew point to 90% RH with 24°C (75.2°F) maximum dew point
Operational altitude de-rating	Maximum temperature is reduced by 1°C/58 m (1.8°F/190 Ft) above 900 m (2953 Ft)

Table 25. Common environmental specifications for ASHRAE A2, NEBS3, GR3108C1+, GR3108C1-L, and NEBS3-H

Feature	Allowable continuous operations
Maximum temperature gradient (applies to both operation and non-operation).	20°C in an hour* (36°F in an hour) and 5°C in 15 minutes (9°F in 15 minutes), 5°C in an hour* (9°F in an hour) for tape hardware
Non-operational temperature limits	-40°C to 65°C (-40°F to 149°F).
Non-operational humidity limits (Non-Condensing at all times)	5% to 95%RH with 27°C (80.6°F) maximum dew point

Table 25. Common environmental specifications for ASHRAE A2, NEBS3, GR3108C1+, GR3108C1-L, and NEBS3-H (continued)

Feature	Allowable continuous operations
Maximum non-operational altitude	12,000 meters (39,370 feet)
Maximum operational altitude	3,050 meters (10,006 feet)

Table 26. Maximum vibration specifications

Maximum vibration	Specifications
Operating	0.21 G _{rms} at 5 Hz to 500 Hz (all operation orientations)
Storage	1.88 G _{rms} at 10 Hz to 500 Hz for 15 minutes (all six sides tested)

Table 27. Maximum shock pulse specifications

Maximum shock pulse	Specifications
Operating	Six consecutively performed shock pulses in the positive and negative x, y, and z axis of 6 G for up to 11 ms (4 pulse on each side on the system)
Storage	Six consecutively performed shock pulses in the positive and negative x, y, and z axis (one pulse on each side of the system) of 71 G for up to 2 ms

Environmental considerations

The PowerEdge system is targeted for edge deployments and it meets all the additional standards for thermal, shock, and vibration parameters.

Table 28. Environmental considerations

Industry	Configuration	Description
Telco	GR-1089-CORE	Electromagnetic Compatibility and Electrical Safety – Generic Criteria for Network Telecommunications Equipment
	GR-63-CORE	NEBS Requirements: Physical Protection
	SR-3580 (NEBS Level 3)	NEBS Criteria Levels
	GR-3108-CORE (Class 1)	Network Equipment in the Outside Plant (OSP). An exception is made for cold boot at +5C instead of -5C for systems without the Heater Manager subsystem enabled.
Military	N/A	
Marine	N/A	
Power Industry	N/A	
Safety	N/A	LDV, IEC/EN, CFR, CSA
EMC	N/A	EN, CISPR, ES, DTAG, CFR, ICES, VCCI
EMV	N/A	RoHS, WEEE, EN, ECE

Particulate and gaseous contamination specifications

The following table defines the limitations that help avoid any equipment damage or failure from particulates and gaseous contamination. If the levels of particulates or gaseous pollution exceed the specified limitations and result in equipment damage or failure, you may must rectify the environmental conditions. Remediation of environmental conditions is the responsibility of the customer.

Table 29. Particulate contamination specifications

Particulate contamination	Specifications
Conductive dust	Air must be free of conductive dust, zinc whiskers, or other conductive particles. <i>i</i> NOTE: This condition applies to data center and non-data center environments.
Corrosive dust	<ul style="list-style-type: none"> Air must be free of corrosive dust. Residual dust present in the air must have a deliquescent point less than 60% relative humidity. <i>i</i> NOTE: This condition applies to data center and non-data center environments.

Table 30. Gaseous contamination specifications

Gaseous contamination	Specifications
Copper coupon corrosion rate	<300 Å/month per Class G1 as defined by ANSI/ISA71.04-2013
Silver coupon corrosion rate	<200 Å/month as defined by ANSI/ISA71.04-2013

Environmental Requirements for installing XR8000

A proper installation of XR8000 protects the system and its components from damage that is caused by external environmental conditions. So, to ensure normal operation and avoid any unplanned downtime and maintenance activity it is highly imperative that there is a proper planning and preparation of the site before installing the XR8000 . Also, it is to be noted that the same site sanity must be maintained during the entire life cycle of the XR8000 server to ensure smooth operations.

General guidelines for maintaining the XR8000:

1. It is recommended to keep the system from heat sources and obstructions blocking the airflow.
2. It is recommended not to allow spillage of liquid into the system and not to operate when the system is wet.
3. If there are any openings in the system, it is recommended not to insert any objects into those points.
4. It is highly advised not to tamper and modify any power cables or PSUs as it could potentially damage the systems.

Site Planning Recommendation:

1. The site should have proper cooling facilities to take care of the operating temperature range of the server.
2. The rack or cabinet where the server is going to be installed should have adequate space for cable routing.
3. The Rack or cabinet should have enough strength to hold the weight of the server.
4. For Conductive dust, the air must be free of conductive dust, zinc whiskers, or other conductive particles. This protects the system from any contamination.
5. For corrosive dust, the air must be free from any corrosive dust and the Residual dust present in the air must have a deliquescent point less than 60% relative humidity. Note this condition applies for both data center and non-data center environments.
6. The system is best found to operate at -5C to 55C and for some conditions from -20C to 65C , so the site conditions could maintain the optimum operating condition.
7. For protection of the system from humidity it is expected to have an environment with a humidity percent range of 8% RH with -12°C minimum dew point to 80% RH with 21°C (69.8°F) maximum dew point.
8. For seismic zones , the maximum operating vibration is 0.21 G _{rms} at 5 Hz to 500 Hz (all operation orientations).

Particulate and gaseous contamination specifications

The following table defines the limitations that help avoid any equipment damage or failure from particulates and gaseous contamination. If the levels of particulates or gaseous pollution exceed the specified limitations and result in equipment damage or failure, you must rectify the environmental conditions. Remediation of environmental conditions is the responsibility of the customer.

Table 31. Particulate contamination specifications

Particulate contamination	Specifications
Air filtration: Conventional Data Center only	<p>Data center air filtration as defined by ISO Class 8 per ISO 14644-1 with a 95% upper confidence limit</p> <p>i NOTE: Filtering room air with a MERV8 filter, as specified in ANSI/ASHRAE Standard 127, is a recommended method for achieving the necessary environmental conditions.</p> <p>i NOTE: Air entering the data center must have MERV11 or MERV13 filtration.</p> <p>i NOTE: This condition applies to data center environments only. Air filtration requirements do not apply to IT equipment designed to be used outside a data center, in environments such as an office or factory floor.</p>
Walk-Up Edge Data Center or Cabinet (sealed, closed loop environment)	<p>Filtration is not required for cabinets that are anticipated to be opened six times or less per year. Class 8 per ISO 1466-1 filtration as defined above is required otherwise.</p> <p>i NOTE: In environments commonly above ISA-71 Class G1 or that may have known challenges, special filters may be required.</p>
Conductive dust: data center and non-data center environments	<p>Air must be free of conductive dust, zinc whiskers, or other conductive particles.</p> <p>i NOTE: Conductive dust, which can interfere with equipment operation, can originate from various sources, including manufacturing processes and zinc whiskers that may develop on the plating of raised floor tiles.</p> <p>i NOTE: This condition applies to data center and non-data center environments.</p>
Corrosive dust: data center and non-data center environments	<ul style="list-style-type: none"> Air must be free of corrosive dust. Residual dust present in the air must have a deliquescent point less than 60% relative humidity. <p>i NOTE: This condition applies to data center and non-data center environments.</p>

Table 32. Gaseous contamination specifications

Gaseous contamination	Specifications	Notes
Copper coupon corrosion rate	ISA-71 Class G1: <300 Å/month	Per ANSI/ISA71.04
Silver coupon corrosion rate	ISA-71 Class G1: <200 Å/month	Per ANSI/ISA71.04

Thermal restriction matrix

XR8610t Sled

Table 33. XR8610t Thermal Restriction - CPU and Memory

Config			Thermal Restriction	
Ambient Temperature			ASHARE A2 (Max 35°C)	NEBS3 (Max 55°C)
CPU	Intel® Xeon® Gold 4514Y	150 W	Supported	Supported
CPU	Intel® Xeon® Gold 6433N	205 W	Supported	Supported
	Intel® Xeon® Gold 6423N	195 W	Supported	Supported
	Intel® Xeon® Gold 6403N	185 W	Supported	Supported

Table 33. XR8610t Thermal Restriction - CPU and Memory (continued)

Config			Thermal Restriction	
Ambient Temperature			ASHARE A2 (Max 35°C)	NEBS3 (Max 55°C)
	Intel® Xeon® Gold 4510	150 W	Supported	Supported
	Intel® Xeon® Gold 5423N	145 W	Supported	Supported
	Intel® Xeon® Gold 4509Y	125 W	Supported	Supported
CPU	Intel® Xeon® Gold 6438N	205 W	Supported	Supported
	Intel® Xeon® Gold 6421N	185 W	Supported	Supported
	Intel® Xeon® Gold 5411N	165 W	Supported	Supported
Memory	DDR5 RDIMM 4800 MT/s 64G		Supported	Supported
	DDR5 RDIMM 4800 MT/s 32G		Supported	Supported
	DDR5 RDIMM 4800 MT/s 16G		Supported	Supported
	DDR5 RDIMM 5600 MT/s 96G		Supported	Supported
	DDR5 RDIMM 5600 MT/s 64G		Supported	Supported
	DDR5 RDIMM 5600 MT/s 32G		Supported	Supported
	DDR5 RDIMM 5600 MT/s 16G		Supported	Supported

NOTE: Do not perform a cold startup below 5°C.

NOTE: 5600 RDIMM thermal qualification with limited speed 4000MT~4800MT which depends on CPU SKU from support list.

Table 34. XR8610t Thermal Restriction - BOSS-N1

Sled Config				XR8620t Thermal Restriction	
Ambient Temperature				ASHRAE A2 (Max 35°C)	NEBS3 (Max 55°C)
BOSS-N1	Hynix M.2	480G	PE8010 2280	Supported	Supported
		480G	PE9010 2280	Supported	Supported
		800G	PE8030 2280	Supported	Supported
		960G	PE8010 2280	Supported	Supported
		960G	PE9010 2280	Supported	Supported
		1.92T	PE9010 2280	Supported	Supported
	Micron M.2	480G	7400 2280	Supported	Supported
		480G	7450 2280	Supported	Supported
		800G	7400 2280	Supported	Supported
		960G	7400 2280	Supported	Supported
		960G	7450 2280	Supported	Supported

NOTE: BOSS-N1 only supports 2280 form factor M.2 SSDs.

Table 35. XR8610t Thermal Restriction - Dual M.2 riser

Sled Config				XR8620t Thermal Restriction	
Ambient Temperature				ASHRAE A2 (Max 35°C)	NEBS3 (Max 55°C)
Dual M.2 riser	Hynix M.2	480G	PE8010 2280	Supported	Supported
		800G	PE8030 2280	Supported	Supported
		960G	PE8010 2280	Supported	Supported
		1.92T	PE8110 22110	Supported	Supported
		3.84T	PE8110 22110	Supported	Supported
	Micron M.2	480G	7400 2280	Supported	Supported
		800G	7400 2280	Supported	Supported
		960G	7400 2280	Supported	Supported
		960G	7450 2280	Supported	Supported
		1.92T	7400 22110	Supported	Supported
		1.92T	7450 22110	Supported	Supported
		3.84T	7400 22110	Supported	Supported
		3.84T	7450 22110	Supported	Supported

NOTE: M.2 drives have performance degradation if there is a fan failure at 55°C.

Table 36. XR8610t Thermal Restriction - Dual M.2 riser + Single M.2 riser

Sled Config				XR8620t Thermal Restriction	
Ambient Temperature				ASHRAE A2 (Max 35°C)	NEBS3 (Max 55°C)
Dual M.2 riser + Single M.2 riser	Hynix M.2	480G	PE8010 2280	Supported	Supported
		800G	PE8030 2280	Supported	Supported
		960G	PE8010 2280	Supported	Supported
		1.92T	PE8110 22110	Supported	Supported
		3.84T	PE8110 22110	Supported	Supported
	Micron M.2	480G	7400 2280	Supported	Supported
		800G	7400 2280	Supported	Supported
		960G	7400 2280	Supported	Supported
		960G	7450 2280	Supported	Supported
		1.92T	7400 22110	Supported	Not supported
		1.92T	7450 22110	Supported	Supported
		3.84T	7400 22110	Supported	Not supported
		3.84T	7450 22110	Supported	Supported

NOTE: BOSS-N1 only supports 2280 form factor M.2 SSDs.

NOTE: M.2 drives have performance degradation if there is a fan failure at 55°C.

Table 37. XR8610t Thermal Restriction - BOSS-N1 + Single M.2 riser

Sled Config				XR8620t Thermal Restriction	
Ambient Temperature				ASHRAE A2 (Max 35°C)	NEBS3 (Max 55°C)
BOSS-N1 + Single M.2 riser	Hynix M.2	480G	PE8010 2280	Supported	Supported
		800G	PE8030 2280	Supported	Supported
		960G	PE8010 2280	Supported	Supported
	Micron M.2	480G	7400 2280	Supported	Supported
		800G	7400 2280	Supported	Supported
		960G	7400 2280	Supported	Supported
		960G	7450 2280	Supported	Supported

NOTE: BOSS-N1 and single M.2 riser only supports 2280 form factor M.2 SSDs.

NOTE: M.2 drives have performance degradation if there is a fan failure at 55°C.

Table 38. XR8610t Thermal Restriction - Commodities

Config	Thermal Restriction	
Ambient Temperature	ASHRAE A2 (Max 35°C)	NEBS3 (Max 55°C)
PCIe Card	Non-Dell PCIe cards are not supported	
PSU	Dual PSUs are required for NEBS3	

Table 39. XR8610t Thermal Restriction - RAN DPU

Sled Config	XR8620t Thermal Restriction	
Ambient Temperature	ASHRAE A2 (Max 35°C)	NEBS3 (Max 55°C)
Qualcomm X100 DPU	Supported	Supported
Nokia Rinline 2 DPU	Supported	Supported
Minerva 3 DPU	Supported	Supported

NOTE: Do not perform a cold startup below 5°C.

XR8620t sled

Table 40. XR8620t Thermal Restriction - CPU and Memory

Sled Config			XR8620t Thermal Restriction				
Ambient Temperature			ASHRAE A2 (Max 35°C)	NEBS3 (Max 55°C)	GR3108C1-L (Max 55°C)	NEBS3-H (Max 65°C)	GR3108C1+ (Max 65°C)
CPU	Intel® Xeon® Gold 4514Y	150 W	Supported	Supported	Supported	Not Supported	Not Supported
CPU	Intel® Xeon® Gold 6433N	205 W	Supported	Supported	Supported	Not Supported	Not Supported
	Intel® Xeon® Gold 6423N	195 W	Supported	Supported	Supported	Supported	Supported

Table 40. XR8620t Thermal Restriction - CPU and Memory (continued)

Sled Config			XR8620t Thermal Restriction				
Ambient Temperature			ASHRAE A2 (Max 35°C)	NEBS3 (Max 55°C)	GR3108C1-L (Max 55°C)	NEBS3-H (Max 65°C)	GR3108C1+ (Max 65°C)
	Intel® Xeon® Gold 6403N	185 W	Supported	Supported	Supported	Supported	Supported
	Intel® Xeon® Gold 4510	150 W	Supported	Supported	Supported	Supported	Supported
	Intel® Xeon® Gold 5423N	145 W	Supported	Supported	Supported	Supported	Supported
	Intel® Xeon® Gold 4509Y	125 W	Supported	Supported	Supported	Supported	Supported
CPU	Intel® Xeon® Gold 6438N	205 W	Supported	Supported	Supported	Not Supported	Not Supported
	Intel® Xeon® Gold 6421N	185 W	Supported	Supported	Supported	Supported	Supported
	Intel® Xeon® Gold 5411N	165 W	Supported	Supported	Supported	Supported	Supported
Memory	DDR5 RDIMM 4800 MT/s 64G		Supported	Supported	Supported	Not Supported	Not Supported
	DDR5 RDIMM 4800 MT/s 32G		Supported	Supported	Supported	Supported	Supported
	DDR5 RDIMM 4800 MT/s 16G		Supported	Supported	Supported	Supported	Supported
	DDR5 RDIMM 5600 MT/s 96G		Supported	Supported	Supported	Not Supported	Not Supported
	DDR5 RDIMM 5600 MT/s 64G		Supported	Supported	Supported	Not Supported	Not Supported
	DDR5 RDIMM 5600 MT/s 32G		Supported	Supported	Supported	Supported	Supported
	DDR5 RDIMM 5600 MT/s 16G		Supported	Supported	Supported	Supported	Supported

NOTE: The heater Manager subsystem is required for “GR3108C1L” and “GR3108C1+” environment class.

NOTE: The heater Manager subsystem is required for the system to perform a cold startup below 5°C.

NOTE: 5600 RDIMM thermal qualification with limited speed 4000MT~4800MT which depends on CPU SKU from support list.

Table 41. XR8620t Thermal Restriction - Raid Controller and Storage (ROR-N1)

Sled Config				XR8620t Thermal Restriction				
Ambient temperature				ASHRAE A2 (Max 35°C)	NEBS3 (Max 55°C)	GR3108C1-L (Max 55°C)	NEBS3-H (Max 65°C)	GR3108C1+ (Max 65°C)
ROR-N1	Hynix M.2	480G	PE8010 2280	Supported	Supported	Supported	Supported	Supported

Table 41. XR8620t Thermal Restriction - Raid Controller and Storage (ROR-N1) (continued)

Sled Config				XR8620t Thermal Restriction				
Ambient temperature				ASHRAE A2 (Max 35°C)	NEBS3 (Max 55°C)	GR3108C1-L (Max 55°C)	NEBS3-H (Max 65°C)	GR3108C1+ (Max 65°C)
		480G	PE9010 2280	Supported	Supported	Supported	Supported	Supported
		800G	PE8030 2280	Supported	Supported	Supported	Not Supported	Not Supported
		960G	PE8010 2280	Supported	Supported	Supported	Not Supported	Not Supported
		960G	PE9010 2280	Supported	Supported	Supported	Not Supported	Not Supported
		1.92T	PE9010 2280	Supported	Supported	Supported	Not Supported	Not Supported
		1.92T	PE8110 22110	Supported	Supported	Supported	Not Supported	Not Supported
		3.84T	PE8110 22110	Supported	Supported	Supported	Not Supported	Not Supported
	Micron M.2	480G	7400 2280	Supported	Supported	Supported	Supported	Supported
		480G	7450 2280	Supported	Supported	Supported	Supported	Supported
		800G	7400 2280	Supported	Supported	Supported	Not Supported	Not Supported
		960G	7400 2280	Supported	Supported	Supported	Not Supported	Not Supported
		960G	7450 2280	Supported	Supported	Supported	Not Supported	Not Supported
		1.92T	7400 22110	Supported	Supported	Supported	Not Supported	Not Supported
		1.92T	7450 22110	Supported	Supported	Supported	Not Supported	Not Supported
		3.84T	7400 22110	Supported	Supported	Supported	Not Supported	Not Supported
		3.84T	7450 22110	Supported	Supported	Supported	Not Supported	Not Supported

 **NOTE:** The heater manager subsystem is required for “GR3108C1L” and “GR3108C1+” environment class.

Table 42. XR8620t Thermal Restriction - Raid Controller and Storage(Non-Raid Riser)

Sled Config				XR8620t Thermal Restriction				
Ambient temperature				ASHRAE A2 (Max 35°C)	NEBS3 (Max 55°C)	GR3108C1-L (Max 55°C)	NEBS3-H (Max 65°C)	GR3108C1+ (Max 65°C)
Non RAID Riser	Hynix M.2	480G	PE8010 2280	Supported	Supported	Supported	Supported	Supported
		480G	PE9010 2280	Supported	Supported	Supported	Supported	Supported
		800G	PE8030 2280	Supported	Supported	Supported	Not Supported	Not Supported
		960G	PE8010 2280	Supported	Supported	Supported	Not Supported	Not Supported
		960G	PE9010 2280	Supported	Supported	Supported	Not Supported	Not Supported
		1.92T	PE9010 2280	Supported	Supported	Supported	Not Supported	Not Supported
		1.92T	PE8110 22110	Supported	Supported	Supported	Not Supported	Not Supported
		3.84T	PE8110 22110	Supported	Supported	Supported	Not Supported	Not Supported
	Micron M.2	480G	7400 2280	Supported	Supported	Supported	Supported	Supported
		480G	7450 2280	Supported	Supported	Supported	Supported	Supported
		800G	7400 2280	Supported	Supported	Supported	Not Supported	Not Supported
		960G	7400 2280	Supported	Supported	Supported	Not Supported	Not Supported
		960G	7450 2280	Supported	Supported	Supported	Not Supported	Not Supported
		1.92T	7400 22110	Supported	Supported	Supported	Not Supported	Not Supported
		1.92T	7450 22110	Supported	Supported	Supported	Not Supported	Not Supported
		3.84T	7400 22110	Supported	Supported	Supported	Not Supported	Not Supported
3.84T	7450 22110	Supported	Supported	Supported	Not Supported	Not Supported		

NOTE: The heater manager subsystem is required for “GR3108C1L” and “GR3108C1+” environment class.

Table 43. XR8620t Thermal Restriction - Raid Controller and Storage(Mancini BOSS-N1)

Sled Config				XR8620t Thermal Restriction				
Ambient temperature				ASHRAE A2 (Max 35°C)	NEBS3 (Max 55°C)	GR3108C1-L (Max 55°C)	NEBS3-H (Max 65°C)	GR3108C1+ (Max 65°C)
BOSS-N1	Hynix M.2	480G	PE8010 2280	Supported	Supported	Not Supported	Supported	Not Supported
		480G	PE9010 2280	Supported	Supported	Not Supported	Not Supported	Not Supported
		800G	PE8030 2280	Supported	Supported	Not Supported	Not Supported	Not Supported
		960G	PE8010 2280	Supported	Supported	Not Supported	Not Supported	Not Supported
		960G	PE9010 2280	Supported	Supported	Not Supported	Not Supported	Not Supported
		1.92T	PE9010 2280	Supported	Supported	Not Supported	Not Supported	Not Supported
	Micron M.2	480G	7400 2280	Supported	Supported	Not Supported	Supported	Not Supported
		480G	7450 2280	Supported	Supported	Not Supported	Not Supported	Not Supported
		800G	7400 2280	Supported	Supported	Not Supported	Not Supported	Not Supported
		960G	7400 2280	Supported	Supported	Not Supported	Not Supported	Not Supported
960G		7450 2280	Supported	Supported	Not Supported	Not Supported	Not Supported	

NOTE: The BOSS-N1 only supports 2280 form factor M.2 SSD.

Table 44. XR8620t Thermal Restriction - Raid Controller and Storage(Non-Raid Riser) + Single M.2 riser

Sled Config				XR8620t Thermal Restriction				
Ambient temperature				ASHRAE A2 (Max 35°C)	NEBS3 (Max 55°C)	GR3108C1-L (Max 55°C)	NEBS3-H (Max 65°C)	GR3108C1+ (Max 65°C)
Non-RAID riser + Single M.2 riser	Hynix M.2	480G	PE8010 2280	Supported	Supported	Not Supported	Not Supported	Not Supported
		800G	PE8030 2280	Supported	Supported	Not Supported	Not Supported	Not Supported
		960G	PE8010 2280	Supported	Supported	Not Supported	Not Supported	Not Supported
		1.92T	PE8110 22110	Supported	Supported	Not Supported	Not Supported	Not Supported
		3.84T	PE8110 22110	Supported	Supported	Not Supported	Not Supported	Not Supported
	Micron M.2	480G	7400 2280	Supported	Supported	Not Supported	Not Supported	Not Supported

Table 44. XR8620t Thermal Restriction - Raid Controller and Storage(Non-Raid Riser) + Single M.2 riser (continued)

Sled Config				XR8620t Thermal Restriction				
Ambient temperature				ASHRAE A2 (Max 35°C)	NEBS3 (Max 55°C)	GR3108C1-L (Max 55°C)	NEBS3-H (Max 65°C)	GR3108C1+ (Max 65°C)
		800G	7400 2280	Supported	Supported	Not Supported	Not Supported	Not Supported
		960G	7400 2280	Supported	Supported	Not Supported	Not Supported	Not Supported
		960G	7450 2280	Supported	Supported	Not Supported	Not Supported	Not Supported
		1.92T	7400 22110	Supported	Supported	Not Supported	Not Supported	Not Supported
		1.92T	7450 22110	Supported	Supported	Not Supported	Not Supported	Not Supported
		3.84T	7400 22110	Supported	Supported	Not Supported	Not Supported	Not Supported
		3.84T	7450 22110	Supported	Supported	Not Supported	Not Supported	Not Supported

Table 45. XR8620t Thermal Restriction - Raid Controller and Storage BOSS-N1 + Single M.2 riser

Sled Config				XR8620t Thermal Restriction				
Ambient temperature				ASHRAE A2 (Max 35°C)	NEBS3 (Max 55°C)	GR3108C1-L (Max 55°C)	NEBS3-H (Max 65°C)	GR3108C1+ (Max 65°C)
BOSS-N1 + Single M.2 riser	Hynix M.2	480G	PE8010 2280	Supported	Supported	Not Supported	Not Supported	Not Supported
		800G	PE8030 2280	Supported	Supported	Not Supported	Not Supported	Not Supported
		960G	PE8010 2280	Supported	Supported	Not Supported	Not Supported	Not Supported
	Micron M.2	480G	7400 2280	Supported	Supported	Not Supported	Not Supported	Not Supported
		800G	7400 2280	Supported	Supported	Not Supported	Not Supported	Not Supported
		960G	7400 2280	Supported	Supported	Not Supported	Not Supported	Not Supported
		960G	7450 2280	Supported	Supported	Not Supported	Not Supported	Not Supported

NOTE: The heater manager subsystem is required for “GR3108C1L” and “GR3108C1+” environment class.

NOTE: The single M.2 riser only supports 2280 form factor M.2 SSD.

NOTE: The heater manager subsystem is not supported when a single M.2 riser is installed.

Table 46. XR8620t Thermal Restriction - Raid Controller and Storage ROR-N1 riser + Single M.2 riser

Sled Config				XR8620t Thermal Restriction				
Ambient temperature				ASHRAE A2 (Max 35°C)	NEBS3 (Max 55°C)	GR3108C1-L (Max 55°C)	NEBS3-H (Max 65°C)	GR3108C1+ (Max 65°C)
ROR-N1 riser + Single M.2 riser 2280/2210 M.2 SSDs	Hynix M.2	480G	PE8010 2280	Supported	Supported	Not Supported	Not Supported	Not Supported
		800G	PE8030 2280	Supported	Supported	Not Supported	Not Supported	Not Supported
		960G	PE8010 2280	Supported	Supported	Not Supported	Not Supported	Not Supported
		1.92T	PE8110 22110	Supported	Supported	Not Supported	Not Supported	Not Supported
		3.84T	PE8110 22110	Supported	Supported	Not Supported	Not Supported	Not Supported
	Micron M.2	480G	7400 2280	Supported	Supported	Not Supported	Not Supported	Not Supported
		800G	7400 2280	Supported	Supported	Not Supported	Not Supported	Not Supported
		960G	7400 2280	Supported	Supported	Not Supported	Not Supported	Not Supported
		960G	7450 2280	Supported	Supported	Not Supported	Not Supported	Not Supported
		1.92T	7400 22110	Supported	Supported	Not Supported	Not Supported	Not Supported
		1.92T	7450 22110	Supported	Supported	Not Supported	Not Supported	Not Supported
		3.84T	7400 22110	Supported	Supported	Not Supported	Not Supported	Not Supported
		3.84T	7450 22110	Supported	Supported	Not Supported	Not Supported	Not Supported

NOTE: The heater Manager subsystem is required for “GR3108C1L” and “GR3108C1+” environment class.

NOTE: The single riser only supports 2280 form factor M.2 SSD.

NOTE: The heater Manager subsystem is not supported when a single M.2 riser is installed.

Table 47. XR8620t Thermal Restriction - RAN DPU

Sled Config	XR8620t Thermal Restriction				
Ambient Temperature	ASHRAE A2 (Max 35°C)	NEBS3 (Max 55°C)	GR3108C1-L (Max 55°C)	NEBS3-H (Max 65°C)	GR3108C1+ (Max 65°C)
Nvidia GPU L4	Supported	Supported	Not Supported	Not Supported	Not Supported
Qualcomm X100 DPU	Supported	Supported	Not Supported	Not Supported	Not Supported
Minerva 3 DPU	Supported	Supported	Not Supported	Not Supported	Not Supported

Table 47. XR8620t Thermal Restriction - RAN DPU (continued)

Sled Config	XR8620t Thermal Restriction				
	ASHRAE A2 (Max 35°C)	NEBS3 (Max 55°C)	GR3108C1-L (Max 55°C)	NEBS3-H (Max 65°C)	GR3108C1+ (Max 65°C)
Nokia Rinline 2 DPU	Supported	Supported	Not Supported	Not Supported	Not Supported

Table 48. XR8620t Thermal Restriction - Commodities

Sled Config	XR8620t Thermal Restriction				
	ASHRAE A2 (Max 35°C)	NEBS3 (Max 55°C)	GR3108C1-L (Max 55°C)	NEBS3-H (Max 65°C)	GR3108C1+ (Max 65°C)
PCIe Card	<ul style="list-style-type: none"> Above 55°C only PCIe cards with Extended Operating Temperature (EOT) Range is supported for "NEBS3-H" & "GR3108C1+". Non-Dell PCIe cards are not supported. 				
Active Optical Cables/ Transceivers	<ul style="list-style-type: none"> Optic cables/transceivers with 70C spec is not supported for "NEBS3-H" & "GR3108C1+". Optic cables/transceivers with 85C spec can support up to 65°C. 				
PSU	-	<ul style="list-style-type: none"> Dual PSUs are required. Only eTemp range PSU is supported for NEBS3-H, GR3108C1L and GR3108C1+ 			

NOTE: The heater Manager subsystem is required for "GR3108C1L" and "GR3108C1+" environment class.

XR8610t- Other Restrictions

- Hot-swap fans are not supported.
- Minimum cold boot temperature +5°C.
- Do not perform a cold startup below 5°C.
- DIMM Blank is required in empty slots.
- Sled blank is required in empty slots.
- PCIE blank is required in the empty slot (slot 1).
- PSU blank is required in empty slots.
- Air baffle is required while single M.2 riser is not installed.

XR8620t- Other Restrictions

- Hot-swap fans are not supported.
- Minimum cold boot temperature +5°C w/o Heater Manager subsystem.
- Minimum cold boot temperature -20°C with Heater Manager subsystem.
- Dual PSUs are required while ambient ≥ 55°C.
- Only PSU with eTemp range is supported for NEBS3 H, GR3108C1 L & GR3108C1+ environment class.
- Non-Dell PCIe Cards are not supported.
- DIMM Blank is required in empty slots.
- Sled blank is required in empty slots.
- PCIE blank is required in empty slots for slot-1&2.
- PCIE blank is required in the empty slot for slot-3.
- PSU blank is required in an empty slot.
- The heater Module is not supported with Intel Ethernet 100G 2P E810-2C.

Heater Manager subsystem

- Telco systems are deployed in remote locations where the systems need to operate in extended (-20C to 39 65C) or extreme (-20C to 55C) temperature ranges. As many of the hardware components (such as iDRAC, 40 CPU, DIMM, SSD, etc.) used in the system cannot operate below 0C, the system needs to be pre-heated to above 5C before the system can power on. Heater Manager subsystem (HM) will pre-heat the system, make sure all the heater zones (9 zones total) are above 5C. The HM heats the system as needed such that the temperatures of all zones are above 5°C.
- The heater Manager subsystem (HM) is only supported in 2U XR8620t.
- Heater Manager subsystem (HM) heating from -20°C to system start booting: ~4 minutes.
- The max power draw per 2U HM sled is about 750 W during the preheat process.

PowerEdge XR8000 acoustics

Dell PowerEdge XR8000 is a 2U multi nodes chassis which can be equipped with XR8620t 2U modular server or XR8610t 1U modular server that was designed for data center acoustics. However, some configurations, e.g., those without GPUs or running GPUs at low loading, may be appropriate for general use spaces.

XR8000 acoustical experience has been tested for Distributed RAN (Telco) (Min Config 1x2U sled) and Centralized RAN (Telco) (Typical Config 2x2U Sled) configurations with XR8620t modular for Front Accessed chassis (also called Reverse Airflow) chassis where power supplies and network cards are in the front. Configuration details are in Table A and associated acoustical values are in Table B. Each configuration has been tested as described in the footnotes.

Table 49. Table A: XR8000 configurations tested for acoustical experience

Configuration	Distributed RAN	Centralized RAN
CPU TDP	205W	205W
CPU Quantity	1	2
RDIMM Memory	16G DDR5 RDIMM	16G DDR5 RDIMM
Memory Quantity	8	16
Backplane Type	N/A	N/A
Storage Type	960G M.2	960G M.2
Storage Quantity	2	4
PSU Type	1100W	1100W
PSU Quantity	2	2
Chassis	XR8000	XR8000
Sled	XR8620t	XR8620t
	1	2
PCI	25 GbE 4Port	100 GbE 2Port
	3 per sled	2 per sled
BOSS N1	N/A	N/A

Table 50. Table B: Acoustical performance of XR8000 configurations

Configuration	Distributed RAN	Centralized RAN	
Acoustical Performance: Idle/ Operating @ 25 °C Ambient			
$L_{wA,m}(B)$	Idle	5.7	6.0
	Operating	5.7	6.0
$K_v(B)$	Idle	0.4	0.4
	Operating	0.4	0.4

Table 50. Table B: Acoustical performance of XR8000 configurations (continued)

Configuration		Distributed RAN	Centralized RAN
L _{pA,m} (dB)	Idle	42	44
	Operating	42	44
Prominent discrete tones		No prominent tones in Idle and Operating Modes	
Acoustical Performance: Idle @ 28 °C Ambient			
L _{wA,m} (B)		5.9	6.3
K _v (B)		0.4	0.4
L _{pA,m} (dB)		44	46
Acoustical Performance: Max. Loading @ 35 °C Ambient			
L _{wA,m} (B)		6.4	6.7
K _v (B)		0.4	0.4
L _{pA,m} (dB)		50	51

- L_{wA,m}: The declared mean A-weighted sound power level (L_{wA}) is calculated per section 5.2 of ISO 9296 with data collected using the methods described in ISO 7779. Engineering data presented here may not be fully compliant with ISO 7779 declaration requirements.
- L_{pA,m}: The declared mean A-weighted emission sound pressure level is at the bystander position per section 5.3 of ISO 9296 and measured using methods described in ISO 7779. The system is placed in a 24U rack enclosure, 25cm above a reflective floor. Engineering data presented here may not be fully compliant with ISO 7779 declaration requirements.
- **Prominent discrete tones:** Criteria of Annex D of ECMA-74 & Prominence Ratio method of ECMA-418 are followed to determine if discrete tones are prominent and to report them, if so.
- **Idle mode:** The steady-state condition in which the server is energized but not operating any intended function.
- **Operating mode:** Operating mode is represented by the maximum of the steady state acoustical output at 50% of CPU TDP or active storage drives for the respective sections of Annex C of ECMA-74.

Rails and mounting options

The rail offerings for the PowerEdge XR8000r supports only static rails.

See the *Enterprise Systems Rail Sizing and Rack Compatibility Matrix* available at [Rail Installation](#) for information regarding:

- Specific details about rail types.
- Rail adjustability ranges for various rack mounting flange types.
- Rack types that are supported for various rack mounting flange types.

Key factors governing proper rail selection include the following:

- Spacing between the front and rear mounting flanges of the rack.
- Type and location of any equipment that is mounted in the back of the rack such as power distribution units (PDUs).
- Overall depth of the rack.

The static rails offer a greater adjustability range and a smaller overall mounting footprint than the sliding rails because of their reduced complexity and lack of need for CMA support. The static rails support a wider variety of racks than the sliding rails. However, they do not support serviceability in the rack and are thus not compatible with the CMA. The static rails are also not compatible with SRB.

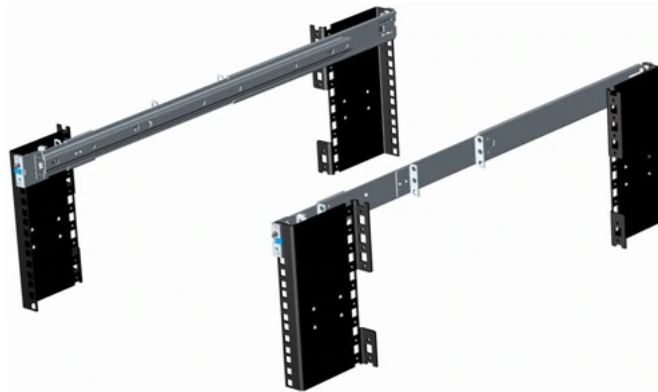

Figure 26. Static rails

Static rails features summary

Static rails for 4-post and 2-post racks:

- Supports Stab-in installation of the chassis to the rails.
- Support tool-less installation in 19" EIA-310-E compliant square or unthreaded round hole 4-post racks including all generations of Dell racks.
- Support tool installation in 19" EIA-310-E compliant threaded hole 4-post and 2-post racks.
- Support for tool installation in Dell Titan or Titan-D rack.
- 4-post racks are limited in size compared to standard datacenter configurations.

NOTE:

- 4 post racks are limited in size and not the normal datacenter size.
- Screws are not included with the static rail kit since racks are offered with various thread types. The screws are provided for mounting static rails in racks with threaded mounting flanges.
- Screw head diameter should be 10 mm or less.

Rack Installation

Table 51. Rack Information

Options	Links to document on Dell support site	Document titles
B31 Rails	PowerEdge Manuals > XR Servers> PowerEdge XR8000r	B31 Rack Installation Guide

Operating Systems and Virtualization

Topics:

- Supported operating systems
- Supported Virtualization

Supported operating systems

Operating system for XR8000

The PowerEdge XR8000 systems support the following operating systems:

- Red Hat Enterprise Linux
- SUSE Linux Enterprise Linux
- WindRiver Solution
- VMware ESXi
- Dell NativeEdge OS

For more information, go to [OS support](#).

Supported Virtualization

VMware vSphere (aka ESXi) is the virtualization software for workload consolidation from physical to virtualized environments.

One of the key features for virtualization on the platform is the support for a failsafe hypervisor. By running the hypervisor on the M.2 drive that is installed on the BOSS card and installing a backup copy on the other M.2 drive (BOSS can support two M.2 drives), you can protect against hardware failure and maximize virtualization uptime. The table below highlights the virtualization support.

Table 52. Supported Virtualization

Operating Systems	Release
VMware	VMware ESXi 8.0
VMware	VMware ESXi 7.0 U3
VMware	VMware Photon RT OS

The current version of ESXi is 8.0 (Nov CY22 GA), and the previous major release 7.0 U3 (Jan CY22 GA) with patch. Both versions support 16G, 15G, and 14G volume servers. With 8.x we do not support 13G Servers, however with 7.x we support a few of the 13G servers refer to the [7.x Server compatibility guide](#) to get the exact list. The certification requires that once a platform is added to VMware Compatibility Guide (VCG), there is continual sustaining certification when new VMware patches, updates, Dell driver, and firmware are updated.

The listing for the certification can be found at [here](#).

Dell Systems Management

Dell delivers management solutions that help IT administrators effectively deploy, update, monitor, and manage IT assets. Dell solutions and tools enable you to quickly respond to problems by helping them to manage Dell servers efficiently; in physical, virtual, local, and remote environments; all without the need to install an agent in the operating system.

The OpenManage portfolio includes:

- Innovative embedded management tools - integrated Dell Remote Access Controller (iDRAC)
- Consoles - OpenManage Enterprise
- Extensible with plug-ins - OpenManage Power Manager
- Update tools - Repository Manager

Dell has developed comprehensive systems management solutions that are based on open standards and has integrated with management consoles from partners such as Microsoft and VMware, allowing advanced management of Dell servers. Dell management capabilities extend to offerings from the industry's top systems management vendors and frameworks such as Ansible, Splunk, and ServiceNow. OpenManage tools automate the full span of server life cycle management activities along with powerful RESTful APIs to script or integrate with your choice of frameworks.

For more information about the entire OpenManage portfolio, see:

- The latest [Dell Systems Management Overview Guide](#).

Topics:

- [Integrated Dell Remote Access Controller \(iDRAC\)](#)
- [Systems Management software support matrix](#)

Integrated Dell Remote Access Controller (iDRAC)

iDRAC9 delivers advanced, agent-free, local and remote server administration. Embedded in every PowerEdge server, iDRAC9 provides a secure means to automate a multitude of common management tasks. Because iDRAC is embedded within every PowerEdge server, there is no additional software to install; just plug in power and network cables, and iDRAC is ready to go. Even before installing an operating system (operating system) or hypervisor, IT administrators have a complete set of server management features at their fingertips.

With iDRAC9 in-place across the Dell PowerEdge portfolio, the same IT administration techniques and tools can be applied throughout. This consistent management platform allows easy scaling of PowerEdge servers as an organization's infrastructure grows. Customers can use the iDRAC RESTful API for the latest in scalable administration methods of PowerEdge servers. With this API, iDRAC enables support for the Redfish standard and enhances it with Dell extensions to optimize at-scale management of PowerEdge servers. By having iDRAC at the core, the entire OpenManage portfolio of Systems Management tools allows every customer to tailor an effective, affordable solution for any size environment.

Zero Touch Provisioning (ZTP) is embedded in iDRAC. ZTP - Zero Touch Provisioning is Intelligent Automation Dell's agent-free management puts IT administrators in control. Once a PowerEdge server is connected to power and networking, that system can be monitored and fully managed, whether you're standing in front of the server or remotely over a network. In fact, with no need for software agents, an IT administrator can: · Monitor · Manage · Update · Troubleshoot and remediate Dell servers With features like zero-touch deployment and provisioning, iDRAC Group Manager, and System Lockdown, iDRAC9 is purpose-built to make server administration quick and easy. For those customers whose existing management platform utilizes in-band management, Dell does provide iDRAC Service Module, a lightweight service that can interact with both iDRAC9 and the host operating system to support legacy management platforms.

When ordered with DHCP enabled from the factory, PowerEdge servers can be automatically configured when they are initially powered up and connected to your network. This process uses profile-based configurations that ensure each server is configured per your specifications. This feature requires an iDRAC Enterprise license.

iDRAC9 offers following license tiers:

Table 53. iDRAC9 license tiers

License	Description
iDRAC9 Basic	<ul style="list-style-type: none"> Available only on 100-500 series rack/tower Basic instrumentation with iDRAC web UI For cost conscious customers that see limited value in management
iDRAC9 Express	<ul style="list-style-type: none"> Default on 600+ series rack/tower, modular, and XR series Includes all features of Basic Expanded remote management and server life-cycle features
iDRAC9 Enterprise	<ul style="list-style-type: none"> Available as an upsell on all servers Includes all features of Basic and Express. Includes key features such as virtual console, AD/LDAP support, and more Remote presence features with advanced, Enterprise-class, management capabilities
iDRAC9 Datacenter	<ul style="list-style-type: none"> Available as an upsell on all servers Includes all features of Basic, Express, and Enterprise. Includes key features such as telemetry streaming, Thermal Manage, automated certificate management, and more Extended remote insight into server details, focused on high end server options, granular power, and thermal management

For a full list of iDRAC features by license tier, see [Integrated Dell Remote Access Controller 9 User's Guide](#) at [Dell.com](#).

For more details on iDRAC9 including white papers and videos, see:

- [Support for Integrated Dell Remote Access Controller 9 \(iDRAC9\)](#) on the [Knowledge Base](#) page at [Dell.com](#)

Systems Management software support matrix

Table 54. Systems Management software support matrix

Categories	Features	PE mainstream
Embedded Management and In-band Services	iDRAC9 (Express, Enterprise, and Datacenter licenses)	Supported
	OpenManage Mobile	Supported
	OM Server Administrator (OMSA)	Supported
	iDRAC Service Module (iSM)	Supported
	Driver Pack	Supported
Change Management	Update Tools (Repository Manager, DSU, Catalogs)	Supported
	Server Update Utility	Supported
	Lifecycle Controller Driver Pack	Supported
	Bootable ISO	Supported
Console and Plug-ins	OpenManage Enterprise	Supported
	Power Manager Plug-in	Supported
	Update Manager Plug-in	Supported
	SupportAssist Plug-in	Supported
	CloudIQ	Supported
Integrations and connections	OM Integration with VMware Vcenter/vROps	Supported
	OM Integration with Microsoft System Center (OMIMSC)	Supported
	Integrations with Microsoft System Center and Windows Admin Center (WAC)	Supported

Table 54. Systems Management software support matrix (continued)

Categories	Features	PE mainstream
	ServiceNow	Supported
	Ansible	Supported
	Third-party Connectors (Nagios, Tivoli, Microfocus)	Supported
Security	Secure Enterprise Key Management	Supported
	Secure Component Verification	Supported
Standard operating system	Red Hat Enterprise Linux, SUSE, Windows Server 2019 or 2022, Ubuntu, CentOS	Supported (Tier-1)

Appendix D: Service and support

Topics:

- [Default support levels](#)
- [Other services and support information](#)

Default support levels

This system offers 3 years Dell ProSupport Next Business Day (NBD), including 24x7 phone support and NBD parts and labor support.

Default deployment levels

The XR Series server sleds are defaulted to **ProDeploy** which includes 24x7 onsite hardware installation and remote software configuration. Deployment of the XR8000r chassis is included at no additional charge with the deployment of the sled. Optionally, the customer may choose any of the factory or field deployment offers listed below.

Other services and support information

Dell Technologies Services include a wide, customizable range of service options to simplify the assessment, design, implementation, management and maintenance of IT environments and to help transition from platform to platform.

Depending on the current business requirements and correct level of service for customers, we provide factory, onsite, remote, modular, and specialized services that fit the customer requirements and budget. We will help with a little or a lot, based on the customer's choice, and provide access to our global resources.

Dell deployment services

Dell ProDeploy Infrastructure Suite

ProDeploy Infrastructure Suite provides a variety of deployment offerings that satisfy a customer's unique needs. It is made up of 5 offers: ProDeploy Configuration Services, ProDeploy Rack Integration Services, Basic Deployment, ProDeploy, and ProDeploy Plus.

ProDeploy Infrastructure Suite for servers

Versatile choices for accelerated deployments

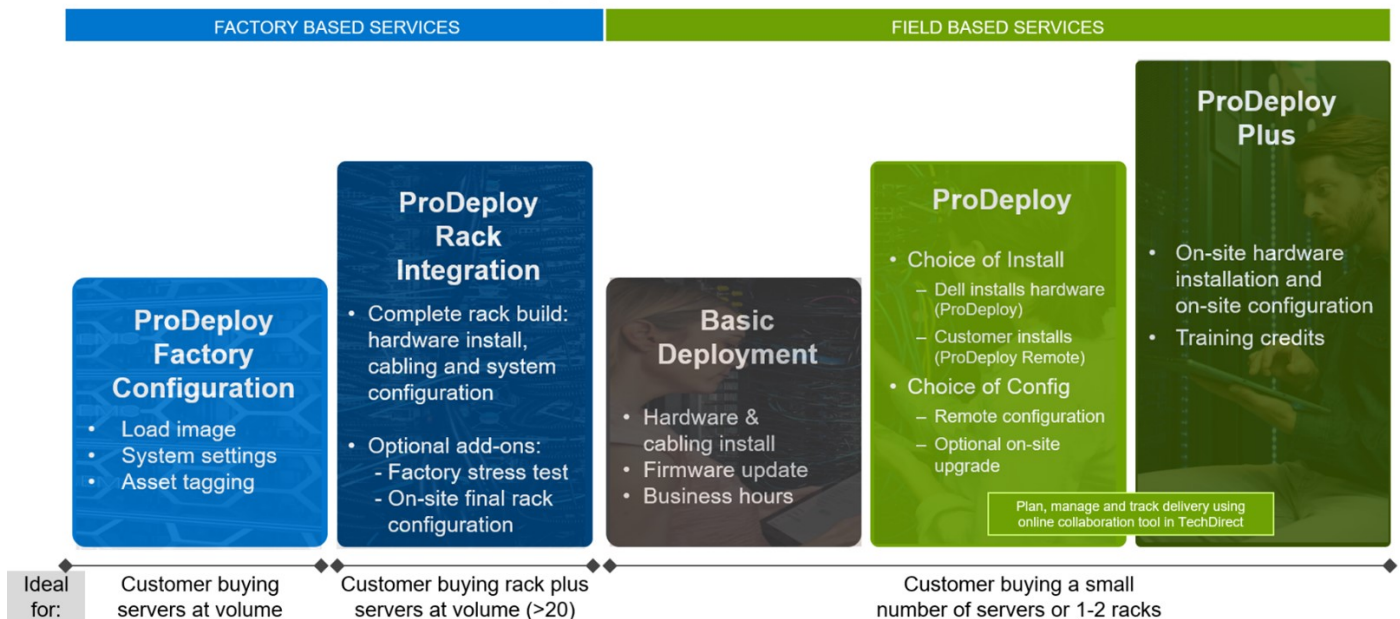

Figure 27. ProDeploy Infrastructure Suite for servers

The new Factory Services consist of two tiers of deployment that happen prior to shipping to the customer's site.

Factory Based Services:

- ProDeploy Factory Configuration - Ideal for customers buying servers in volume and seeking pre-configuration prior to shipping such as: custom image, system settings, and asset tagging so it arrives ready to use out of the box. Furthermore, servers can be packaged and bundled to meet specific shipping and distribution requirements for each customer location to facilitate the rollout process. Upsell one of the field based services (below) if a customer needs assistance with the final server installation.
- ProDeploy Rack Integration - Ideal for customers seeking to build out fully integrated racks prior to shipping. These rack builds include hardware install, cabling, and full system configuration. You can also add-on a factory stress test and optional on-site final rack configuration to complete the rack installation.
 - STANDARD SKUs for Rack Integration is available in US only and requires:
 - 20 or more devices (R and C series servers and all Dell or non-Dell switches). Use Informational SKUs for Dell switches or 3rd party products
 - Shipping to contiguous US
 - USE CUSTOM QUOTE for Rack Integration for:
 - All countries except USA
 - Racks containing less than 20 servers
 - Any rack that includes VxRail or Storage
 - Shipping outside contiguous US
 - Shipping to multiple locations

Field Based Services:

- Basic Deployment consists of the hardware installation, cabling and firmware update during normal standard business hours. Basic Deployment is traditionally sold to Competency Enabled Partners. Competency enabled partners often have Dell do the hardware installation while they complete the software configuration.
- ProDeploy consists of your hardware installation and configuration of the software using offshore resources. ProDeploy is great for customers who are price sensitive or who are remote from their data centers and don't require an onsite presence.
- ProDeploy Plus will give you in-region or onsite resources to complete the engagement for the customer. It also comes with additional features such as Post Deployment Configuration Assistance and Training Credits.

ProDeploy Infrastructure Suite | Factory services

FACTORY BASED SERVICES

		ProDeployFactory Configuration	ProDeploy Rack Integration
Asset configuration	Single point of contact for project management	●	●
	RAID, BIOS and iDRAC configuration	●	●
	Firmware freeze	●	●
	Asset Tagging and Reporting	●	●
	Customer system image	●	●
Factory implementation	Site readiness review and implementation planning	-	●
	Hardware racking and cabling	-	●
	SAM engagement for ProSupport Plus entitled accounts/devices	-	●
	Deployment verification, documentation, and knowledge transfer	●	●
Delivery	White glove logistics	-	●
	Onsite final configuration	-	Onsite add-on
	Install support software and connect with Dell Technologies	-	Onsite add-on
	Basic Deployment	Optional onsite installation	-
Online oversight	Online collaborative environment for planning, managing and tracking delivery	-	●

¹ ProDeployRack Integration Services are currently only available within the United States. Custom rack integration services are still available globally.*

Dell Technologies

Figure 28. ProDeploy Infrastructure Suite - Factory services

ProDeploy Infrastructure Suite | Field services

		Basic Deployment	ProDeploy	ProDeploy Plus
Pre-deployment	Single point of contact for project management	●	●	In-region
	Site readiness review	-	●	●
	Implementation planning ¹	-	●	●
	SAM engagement for ProSupport Plus entitled devices	-	-	●
Deployment	Deployment service hours	Business hours	24x7	24x7
	Onsite hardware installation and packaging material removal ² or remote guidance for hardware installation ¹	●	Remote guidance or onsite	Onsite
	Install and configure system software	-	Remote	Onsite
	Install support software and connect with Dell Technologies	-	●	●
	Project documentation with knowledge transfer	-	●	●
Post-deployment	Deployment verification	-	●	●
	Configuration data transfer to Dell Technologies technical support	-	●	●
	30-days of post-deployment configuration assistance	-	-	●
	Training credits for Dell Technologies Education Services	-	-	●
Online oversight	Online collaborative environment in TechDirect for planning, managing and tracking delivery ³	-	●	●

¹ Remote option includes project specific instructions, documentation and live expert guidance for hardware installation. Option available for select hardware. [List is available in the backup portion of this customer presentation](#)

² Packaging removal included with onsite hardware installation

³ Included with ProDeploy or ProDeploy Plus, Not included with Basic Deployment

Figure 29. ProDeploy Infrastructure Suite - Field services

Dell ProDeploy Plus for Infrastructure

From beginning to end, ProDeploy Plus provides the skill and scale that is must successfully perform demanding deployments in today's complex IT environments. Certified Dell experts start with extensive environmental assessments and detailed migration

planning and recommendations. Software installation includes set up of our enterprise connectivity solution (secure connect gateway) and OpenManage system management utilities.

Postdeployment configuration assistance, testing, and product orientation services are also available.

Dell ProDeploy for Infrastructure

ProDeploy provides full-service installation and configuration of both server hardware and system software by certified deployment engineers including set up of leading operating systems and hypervisors as well our enterprise connectivity solution (secure connect gateway) and OpenManage system management utilities. To prepare for the deployment, we conduct a site readiness review and implementation planning exercise. System testing, validation, and full project documentation with knowledge transfer complete the process.

Dell Basic Deployment

Basic Deployment delivers worry-free professional installation by experienced technicians who know Dell servers inside and out.

Additional Deployment Services

You can tailor the ProDeploy Infrastructure Suite offer to meet your customer's unique needs by leveraging "Additional Deployment Time." ADT will cover additional tasks above the normal scope of the standard offers. ADT can be sold for Project Management or Technical Resources and is sold as blocks of four hours remote or eight hours on-site.

Dell ProDeploy for HPC (available in US/Canada only. All other regions use custom)

HPC deployments require specialists that understand that cutting edge is yesterday's news. Dell deploys the world 's fastest systems and understands the nuances that make them perform. ProDeploy for HPC provides:

- Global team of dedicated HPC specialists
- Proven track record, thousands of successful HPC deployments
- Design validation, benchmarking, and product orientation

Learn more at Dell.com/HPC-Services.

ProDeploy Expansion for HPC

*Available as standard SKUs in US & Canada and as custom quote in APJC, EMEA, LATAM

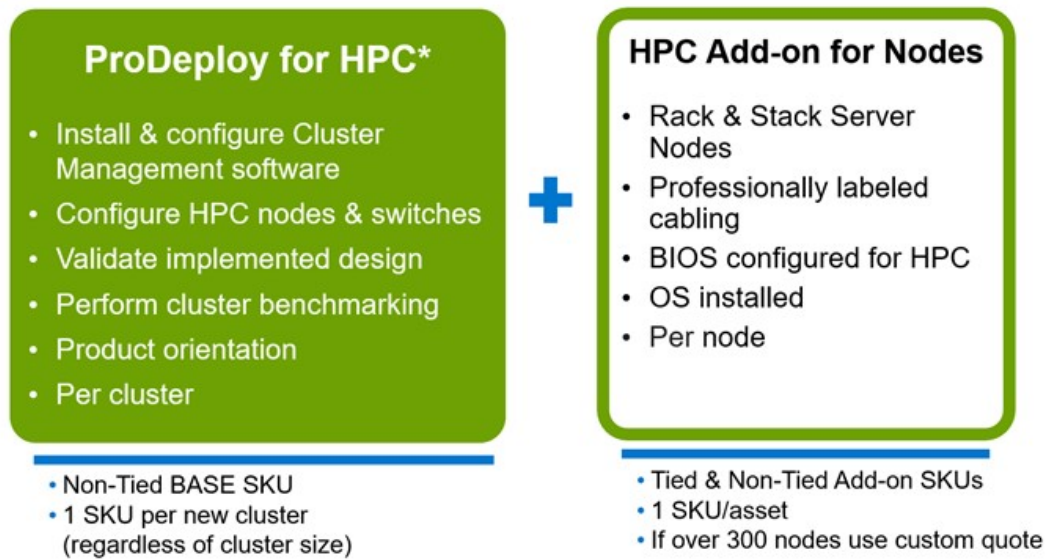

Figure 30. ProDeploy Expansion for HPC

Dell custom deployment Services

Dell custom rack integration and other Dell configuration services help customers save time by providing systems that are racked, cabled, tested, and ready to be integrated into the data center. Dell support preconfigure RAID, BIOS and iDRAC settings, install system images, and even install third-party hardware and software.

For more information, see [Server Configuration Services](#).

Dell Residency Services

Residency Services help customers transition to new capabilities quickly with the assistance of onsite or remote Dell experts whose priorities and time they control.

Residency experts can provide post implementation management and knowledge transfer that is related to a new technology acquisition or day-to-day operational management of the IT infrastructure.

Dell Data Migration Services

Protect business and data of the customer with our single point of contact to manage data migration projects.

A customer project manager works with our experienced team of experts to create a plan using industry-leading tools and proven processes that are based on global best practices to migrate existing files and data, so business systems are up and running quickly and smoothly.

Dell Enterprise Support Services

Dell ProSupport Enterprise Suite

With the ProSupport Enterprise Suite, we help keep IT systems running smoothly, so customers can focus on running their business. We help maintain peak performance and availability of the most essential workloads. ProSupport Enterprise Suite is a suite of support services that enable customers to build the solution that is right for their organization. They choose support models that are based on how they use technology and where they want to allocate resources. From the desktop to the data center, address everyday IT challenges, such as unplanned downtime, mission-critical needs, data and asset protection, support planning, resource allocation, software application management and more. Optimize customer IT resources by choosing the right support model.

Table 55. ProSupport Enterprise Suite

Service	Support model	Description
ProSupport Enterprise Suite	ProSupport Plus for Enterprise	Proactive, predictive, and reactive support for systems that look after your business-critical applications and workloads
	ProSupport for Enterprise	Comprehensive 24 x 7 predictive and reactive support for hardware and software
	Basic hardware support	Reactive hardware support during normal business hours

Dell ProSupport Plus for Enterprise

When customers purchase PowerEdge server, we recommend ProSupport Plus, our proactive and preventative support service for business-critical systems. ProSupport Plus provides all the benefits of ProSupport, plus the following:

- An assigned Services Account Manager who knows their business and environment
- Immediate advanced troubleshooting from an engineer
- Personalized, preventive recommendations that are based on analysis of support trends and best practices from across the Dell Technologies infrastructure solutions customer base to reduce support issues and improve performance
- Predictive analysis for issue prevention and optimization that is enabled by secure connect gateway technology
- Proactive monitoring, issue detection, notification, and automated case creation for accelerated issue resolution enabled by secure connect gateway
- On-demand reporting and analytics-based recommendations that are enabled by secure connect gateway and TechDirect

Dell ProSupport for Enterprise

ProSupport service offers highly trained experts around the clock and around the globe to address IT needs. We help minimize disruptions and maximize availability of PowerEdge server workloads with:

- 24x7 support through phone, chat and online
- Predictive, automated tools and innovative technology
- A central point of accountability for all hardware and software issues
- Collaborative third-party support
- Hypervisor, operating system and application support
- Consistent experience regardless of where customers are located or what language they speak

 **NOTE:** Subject to service offer country or region availability.

- Optional onsite parts and labor response options including next business day or four-hour mission critical

ProSupport Enterprise Suite Feature Comparison			
	Basic	ProSupport	ProSupport Plus
Remote technical support	9x5	24x7	24x7
Covered products	Hardware	Hardware Software	Hardware Software
Onsite hardware support	Next business day	Next business day or 4hr mission critical	Next business day or 4 hr mission critical
3 rd party collaborative assistance		●	●
Self-service case initiation and management		●	●
Access to software updates		●	●
Proactive storage health monitoring, predictive analytics and anomaly detection with CloudIQ and the CloudIQ mobile app		●	●
Priority access to specialized support experts			●
Predictive detection of hardware failures			●
3 rd party software support			●
An assigned Service Account Manager			●
Proactive, personalized assessments and recommendations			●
Proactive systems maintenance			●

Availability and terms of Dell Technologies Services vary by region and by product. For more information, please view our [service descriptions](#).

Internal Use - Confidential 23 of 117 © Copyright 2022 Dell Inc. **DELL** Technologies

Figure 31. ProSupport Enterprise Suite

Dell ProSupport One for Data Center

ProSupport One for Data Center offers flexible site-wide support for large and distributed data centers with more than 1,000 assets. This offering is built on standard ProSupport components that leverage our global scale but are tailored to a customer's needs. While not for everyone, this service option offers a truly unique solution for Dell Technologies largest customers with the most complex environments.

- Team of assigned Services Account Managers with remote, on-site options
- Assigned ProSupport One technical and field engineers who are trained on the customer's environment and configurations
- On-demand reporting and analytics-based recommendations that are enabled by secure connect gateway and TechDirect
- Flexible on-site support and parts options that fit their operational model
- A tailored support plan and training for their operations staff

Dell ProSupport Add-on for HPC

The ProSupport Add-on for HPC provides solution-aware support including:

- Access to senior HPC experts
- Advanced HPC cluster assistance: performance, interoperability, and configuration
- Enhanced HPC solution level end-to-end support
- Remote presupport engagement with HPC Specialists during ProDeploy implementation

Learn more at Dell.com/HPC-Services.

ProSupport Add-on for HPC is an add-on to PS or PSP

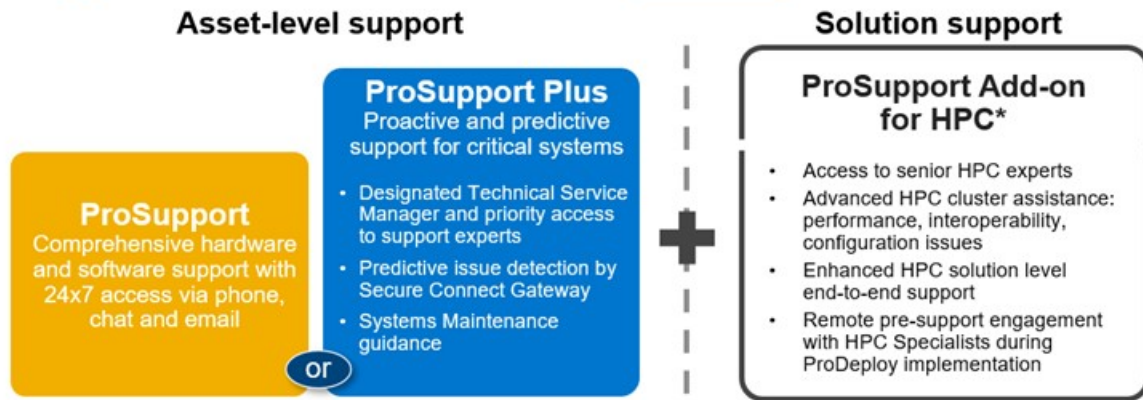

Eligibility

- All server, storage, and networking nodes in cluster must have PS or PSP **AND** PS Add-on for HPC attached
- All HW expansions to clusters must attach PS or PSP **AND** PS Add-on for HPC
- To retrofit an entire existing cluster with PS Add-on for HPC:
 1. HPC Specialists must review and validate the existing cluster
 2. PS or PSP **AND** the PS Add-on for HPC (APOS) must be attached to all server, storage and networking nodes

*Available in standard SKUs in NA and EMEA and as custom quote in APJC & LATAM

DELLTechnologies

Figure 32. ProSupport Add-on for HPC is an add-on to PS or PSP

Support Technologies

Powering the support experience with predictive, data-driven technologies.

NOTE: SupportAssist Enterprise capabilities are now part of the secure connect gateway technology.

Enterprise connectivity

The best time to solve a problem is before it happens. The automated proactive and predictive support features enabled by the secure connect gateway technology helps reduce steps and time to resolution, often detecting issues before they become a crisis. The gateway technology is available in virtual and application editions. It is also implemented as a direct connect version for select Dell hardware and a Services plugin within OpenManage Enterprise for PowerEdge servers. The legacy SupportAssist Enterprise solution has been retired and is now replaced by the secure connect gateway solutions.

Benefits include:

- Value: Our connectivity solutions are available to all customers at no additional charge
- Improve productivity: Replace manual, high-effort routines with automated support
- Accelerate time to resolution: Receive issue alerts, automatic case creation, and proactive contact from Dell experts
- Gain insight and control: Optimize enterprise devices with insights in portals reporting like TechDirect, and get predictive issue detection before the problem starts

NOTE: Connect devices can access these features. Features vary depending on the service level agreement for the connected device. ProSupport Plus customers experience the full set of automated support capabilities.

Table 56. Features enabled by connectivity

	Basic hardware warranty	ProSupport	ProSupport Plus
Automated issue detection and system state information collection	Supported	Supported	Supported
Proactive, automated case creation and notification	Not supported	Supported	Supported

Table 56. Features enabled by connectivity (continued)

	Basic hardware warranty	ProSupport	ProSupport Plus
Predictive issue detection for failure prevention	Not supported	Not supported	Supported

Get started at DellTechnologies.com/secureconnectgateway.

Dell TechDirect

TechDirect helps boost IT team productivity when supporting Dell systems.

Boost your productivity with online service for Dell products from TechDirect. From deployment to technical support, TechDirect lets you do more with less effort and faster resolution. You can:

- Open and manage support requests or in-warranty systems
- Execute online self-service for parts dispatch
- Collaborate on ProDeploy infrastructure deployment projects online
- Manage proactive and predictive alerts from secure connect gateway technology that help maximize uptime
- Integrate services functionality into your help desk with TechDirect APIs
- Join over 10,000 companies that choose TechDirect

Register at TechDirect.Dell.com.

Dell Technologies Consulting Services

Our expert consultants help customers transform faster, and quickly achieve business outcomes for the high value workloads Dell PowerEdge systems can handle. From strategy to full-scale implementation, Dell Technologies Consulting can help determine how to perform IT, workforce, or application transformation. We use prescriptive approaches and proven methodologies that are combined with portfolio and partner ecosystem of Dell Technologies to help achieve real business outcomes. From multi cloud, applications, DevOps, and infrastructure transformations, to business resiliency, data center modernization, analytics, workforce collaboration, and user experiences-we are here to help.

Dell Managed Services

Some customers prefer Dell to manage the complexity and risk of daily IT operations, Dell Managed Services utilizes proactive, AI enabled delivery operations and modern automation to help customers realize desired business outcomes from their infrastructure investments. With these technologies, our experts run, update and fine-tune customer environments aligned with service levels, while providing environment-wide and down-to-the-device visibility. There are two types of managed service offers. First the outsourcing model or CAPEX model where Dell manages the customer owned assets using our people and tools. The second is the as-a-Service model or OPEX model called APEX. In this service, Dell owns all technology and all the management of it. Many customers will have a blend of the two management types depending on the goals of the organization.

Managed	Outsourcing or CAPEX model	APEX	as-a-Service or OPEX model
<p>We manage your technology using our people and tools.¹</p> <ul style="list-style-type: none"> • Managed detection and response* • Technology Infrastructure • End-user (PC/desktop) • Service desk operations • Cloud Managed (Pub/Private) • Office365 or Microsoft Endpoint 		<p>We own all technology so you can off-load all IT decisions.</p> <ul style="list-style-type: none"> • APEX Cloud Services • APEX Flex on Demand elastic capacity • APEX Data Center Utility pay-per-use model 	

1 – Some minimum device counts may apply. Order via: ClientManagedServices.sales@dell.com

* Managed detection and response covers the security monitoring of laptops, servers, & virtual servers. Min. 50 devices combined. No Networking or Storage-only systems [SAN/NAS]. Available in 32 countries. [Details here](#)

Figure 33. Dell Managed Services

Dell Technologies Education Services

Build the IT skills required to influence the transformational outcomes of the business. Enable talent and empower teams with the right skills to lead and perform transformational strategy that drives competitive advantage. Leverage the training and certification required for real transformation.

Dell Technologies Education Services offers PowerEdge server training and certifications that are designed to help customers achieve more from their hardware investment. The curriculum delivers the information and the practical, firsthand skills that their team must confidently install, configure, manage, and troubleshoot Dell servers.

To learn more or register for a class today, see Education.Dell.com.

Appendix A. Additional specifications

Topics:

- Chassis dimensions
- System weight
- Video specifications
- PSU specifications
- System board jumpers and connectors

Chassis dimensions

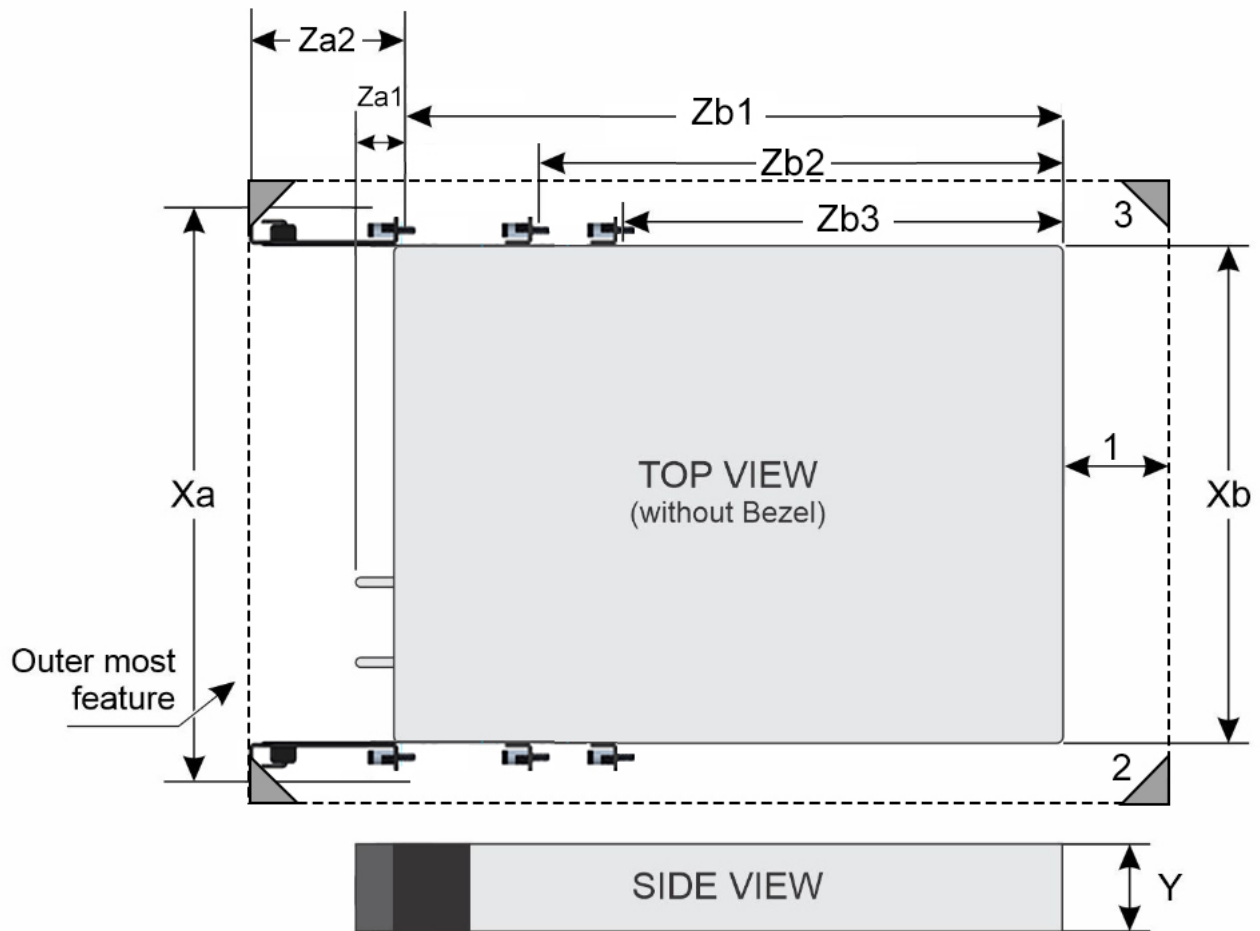

Figure 34. Chassis dimensions

Table 57. PowerEdge XR8000r chassis dimensions

Xa	Xb	Y	Za1	Za2	Zb1	Zb2	Zb3
482 mm (18.97 inches) includes rack mount ear.	448 mm (17.63 inches)	87.05 mm (3.42 inches)	30.4 mm (1.19 inches)	89 mm (3.50 inches) with cable	423 mm (16.65 inches)	343 mm (13.50 inches)	293 mm (11.53 inches)

Table 57. PowerEdge XR8000r chassis dimensions

Xa	Xb	Y	Za1	Za2	Zb1	Zb2	Zb3
			Bezel not supported	management kit included			

NOTE: The XR8000r can support racks/cabinets with a minimum space of 30.4 mm between the front post of the rack and the inside surface of the rack door, without the included cable management kit. The minimum front space required might be limited by front cable bending. When using the included cable management kit, the XR8000r can support racks/cabinets with a minimum distance of 89 mm between the front post of the rack and the inside surface of the rack door. Other important parameters in the image are:

1. Minimum exhaust gap (between chassis rear and cabinet’s rear door) required for thermal performance:
 - a. 50 mm minimum for ambient temperatures up to 55°C
 - b. 55 mm minimum for ambient temperatures 55 - 65°C
2. Four post rack.
3. 19-inch or 23-inch width cabinet boundary and 600 mm (23.62 inches) minimum cabinet depth.

System weight

Table 58. PowerEdge XR8000r system weight

System configuration	Maximum weight (with all drives/SSDs)
Weight of chassis without sleds	5.82 kg (12.8 pounds)
Weight of chassis with two XR8620t sleds	18.52 kg (40.84 pounds)

Table 59. PowerEdge system weight handling recommendations

Chassis weight	Description
40 pounds - 70 pounds	Recommend two persons to lift.
70 pounds- 120 pounds	Recommend three persons to lift.
≥ 121 pounds	Recommend to use a server-lift.

NOTE: If moving the chassis, it is recommended to remove all the sleds from the chassis.

Video specifications

The PowerEdge XR8620t systems support integrated Matrox G200 graphics controller embedded in the iDRAC (BMC) chip, with 16 MB of video frame buffer.

Table 60. Supported video resolution options

Resolution	Refresh rate (Hz)	Color depth (bits)
640 x 480	60	8, 16, 32
800 x 600	60	8, 16, 32
1024 x 768	60	8, 16, 32
1152 x 864	60	8, 16, 32
1280 x 800	60	8, 16, 32
1280 x 1024	60	8, 16, 32
1360 x 768	60	8, 16, 32

Table 60. Supported video resolution options (continued)

Resolution	Refresh rate (Hz)	Color depth (bits)
1400 x 1050	60	8, 16, 32
1440 x 900	60	8, 16, 32
1600 x 1200	60	8, 16, 32
1680 x 1050	60	8, 16, 32
1920 x 1080	60	8, 16, 32
1920 x 1200	60	8, 16, 32

PSU specifications

The PowerEdge XR8000r system supports up to two AC or DC power supply units (PSUs).

Table 61. PSU specifications

PSU	Class	Heat dissipation (maximum) (BTU/hr)	Frequency (Hz)	Voltage	AC		DC	Current (A)
					High line 200–240 V	Low line 100–120 V		
1800 W Mixed Mode	Titanium	6750 BTU/hr	50/60 Hz	200–240 V AC	1800 W	N/A	N/A	10 A
		6750 BTU/hr	N/A	240 V DC	N/A	N/A	1800 W	8.2 A
1400 W Mixed Mode	Platinum	5250 BTU/hr	50/60 Hz	100–240 V AC	1400 W	1050 W	N/A	12 A - 8 A
		5250 BTU/hr	N/A	240 V DC	N/A	N/A	1400 W	6.6 A
1400 W DC	N/A	5310 BTU/hr	N/A	-48—(-60) V	N/A	N/A	1400 W	33.5 A
1100 W DC	N/A	4265 BTU/hr	N/A	-48—(-60) V	N/A	N/A	1100 W	27 A
800 W DC	N/A	3219 BTU/hr	N/A	-48—(-60) V	N/A	N/A	800 W	20 A

- NOTE:** To update PSU firmware successfully, it is necessary to have both PSUs installed in the chassis.
- NOTE:** All PSUs come in Reverse Airflow (RAF) offerings (Reverse Airflow PSUs).
- NOTE:** This system is also designed to connect to the IT power systems with a phase-to-phase voltage not exceeding 240 V.
- NOTE:** Heat dissipation is calculated using the PSU wattage rating.
- NOTE:** For information about DC PSU cabling instructions, see the Cabling instructions for - (48 - 60) V DC power supply Tech sheet that is shipped with your DC PSU or go to <https://www.dell.com/poweredgemanuals> > XR Servers > PowerEdge XR8000r > Select This Product > Documentation > Manuals and Documents > Cabling instructions for - 48 - 60 V DC power supply
- NOTE:** When selecting or upgrading the system configuration, to ensure optimum power utilization, verify the system power consumption with the Enterprise Infrastructure Planning Tool available at [calc](#).

System board jumpers and connectors

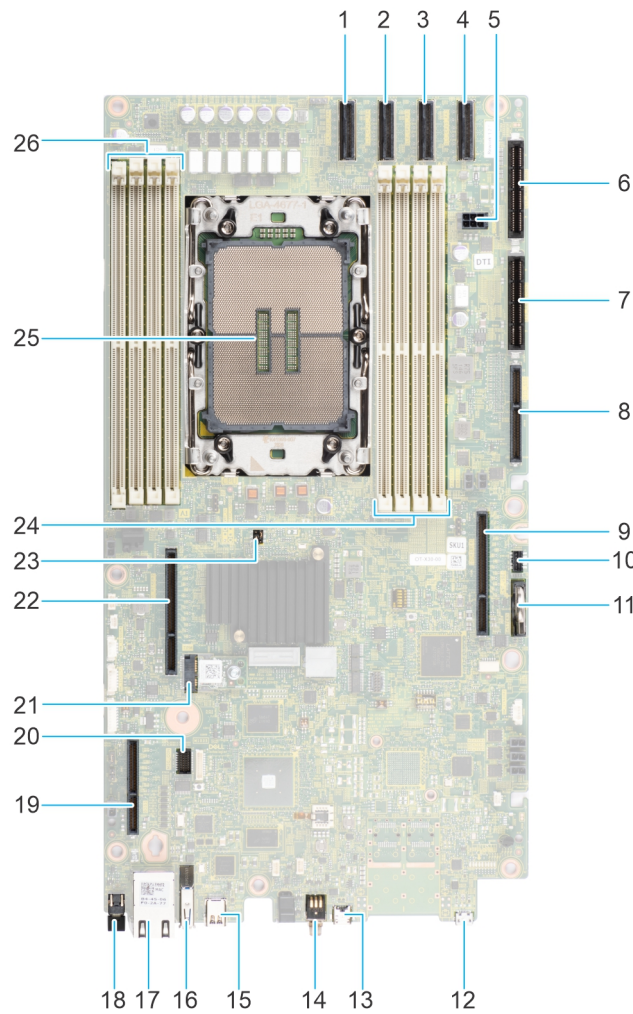

Figure 35. System board connectors

Table 62. System board connectors description

Item	Connector	Description
1	SL4_CPU1_PA4	PCIe connector 4
2	SL3_CPU1_PB4	PCIe connector 3
3	SL2_CPU1_PB3	PCIe connector 2
4	SL1_CPU1_PA3	PCIe connector 1
5	J_R1_PWR	PCIe Extension Power
6	SYS_PWR_CONN1	Power connector 1
7	SYS_PWR_CONN2	Power connector 2
8	PIB Signal	PIB Signal
9	IO_RISER1	Riser 1 connector
10	Reserved(INT_USB1)	Reserved for debug purpose
11	Coin cell battery	Coin cell battery

Table 62. System board connectors description (continued)

Item	Connector	Description
12	Micro-USB Serial	Micro-USB Serial Port
13	iDRAC_DIRECT	iDRAC Direct Port
14	SYS_ID	System ID button
15	Display	Display Port
16	USB	USB 3.0 connector
17	iDRAC RJ45/Dry Input	iDRAC RJ45/Dry Input
18	POWER	Power button
19	BOSS-N1	BOSS-N1 M.2 connector
20	MIC_CON	Smart NIC connector
21	TPM	TPM connector
22	Single M.2 riser	Riser 2 connector
23	JUMPER	BIOS password and NVRAM jumper
24	A4, A6, A2, A8	DIMM slots (A4, A6, A2, A8)
25	CPU	Processor socket
26	A5, A3, A7, A1	DIMM slots (A5, A3, A7, A1)

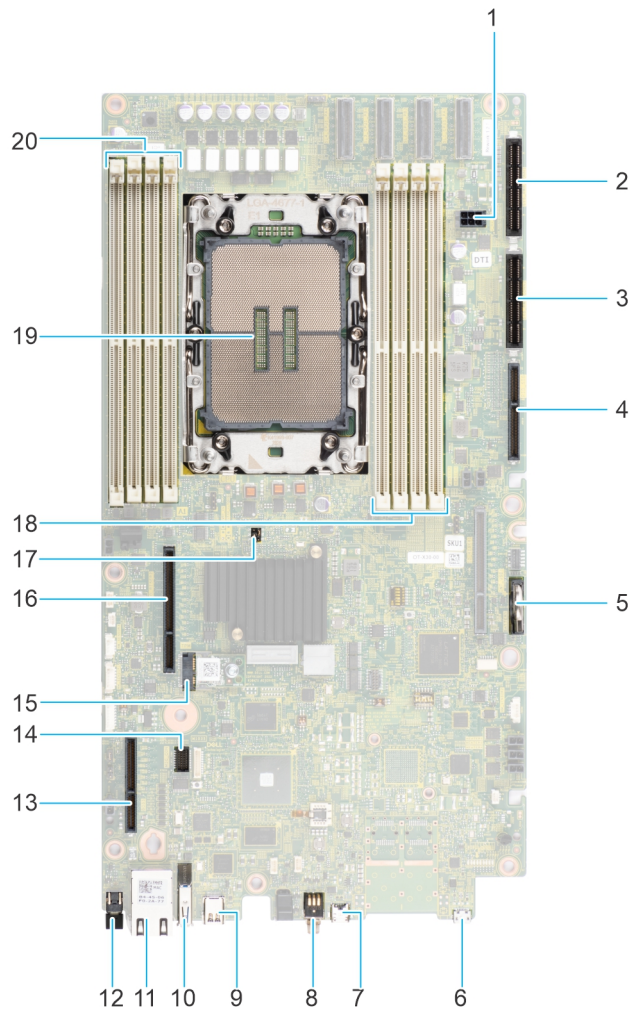

Figure 36. System board connectors

Table 63. System board connectors description

Item	Connector	Description
1	J_R1_PWR	PCIe Extension Power
2	SYS_PWR_CONN1	Power connector 1
3	SYS_PWR_CONN2	Power connector 2
4	PIB Signal	PIB Signal connector
5	Coin cell battery	Coin cell battery
6	Micro-USB Serial	Micro-USB Serial Port
7	iDRAC_DIRECT	iDRAC Direct Port
8	SYS_ID	System ID button
9	Display	Display Port
10	USB	USB 3.0 connector
11	iDRAC RJ45/Dry Input	iDRAC RJ45/Dry Input
12	POWER	Power button
13	BOSS-N1	BOSS-N1 M.2 connector

Table 63. System board connectors description (continued)

Item	Connector	Description
14	MIC_CON	Smart NIC connector
15	TPM	TPM connector
16	Single M.2 riser	Riser 2 connector
17	JUMPER	BIOS password and NVRAM jumper
18	A4, A6, A2, A8	DIMM slots (A4, A6, A2, A8)
19	CPU	Processor socket
20	A5, A3, A7, A1	DIMM slots (A5, A3, A7, A1)

i **NOTE:** J_R1 PWR1 and J_R1_PWR2 is for PCIE Riser1 Slot1 Slimline power and Slot2 Slimline power. They are located on 2U PDB board

Appendix B. Standards compliance

The system conforms to the following industry standards.

Table 64. Industry standard documents

Standard	URL for information and specifications
ACPI Advance Configuration and Power Interface Specification, v6.4	Uefi specifications and tools
Ethernet IEEE Std 802.3-2022	ieee standards
IPMI Intelligent Platform Management Interface, v2.0	intel.com/design/servers/ipmi
DDR5 Memory DDR5 SDRAM Specification	jedec.org/standards-documents/docs/jesd79-4.pdf
PCI Express PCI Express Base Specification, v5.0	pcisig.com/specifications/pciexpress
PMBus Power System Management Protocol Specification, v1.2	pmbus specification and revisions
SMBIOS System Management BIOS Reference Specification, v3.3.0	BIOS reference specification page
TPM Trusted Platform Module Specification, v1.2 and v2.0	trustedcomputinggroup org page
UEFI Unified Extensible Firmware Interface Specification, v2.7	UEFIF specifications
PI Platform Initialization Specification, v1.7	
USB Universal Serial Bus v2.0 and SuperSpeed v3.0 (USB 3.1 Gen1)	USB Implementers Forum, Inc. USB document library
NVMe Express Base Specification. Revision 2.0c	NVME specifications
NVMe Command Set Specifications	
1. NVMe Express NVMe Command Set Specification. Revision 1.1c	
2. NVMe Express Zoned Namespaces Command Set. Revision 1.0c	
3. NVMe Express® Key Value Command Set. Revision 1.0c	
NVMe Transport Specifications	
1. NVMe Express over PCIe Transport. Revision 1.0c	
2. NVMe Express RDMA Transport Revision. 1.0b	
3. NVMe Express TCP Transport. Revision 1.0c	
NVMe NVMe Express Management Interface. Revision 1.2c	
NVMe NVMe Boot Specification. Revision 1.0	

Appendix C Additional resources

Table 65. Additional resources

Resource	Description of contents	Location
Installation and Service Manual	<p>This manual, available in PDF format, provides the following information:</p> <ul style="list-style-type: none"> • Chassis features • System Setup program • System indicator codes • System BIOS • Remove and replace procedures • Diagnostics • Jumpers and connectors 	Dell.com/Support/Manuals
Getting Started Guide	<p>This guide ships with the system, and is also available in PDF format. This guide provides the following information:</p> <ul style="list-style-type: none"> • Initial setup steps 	Dell.com/Support/Manuals
Rack Installation Guide	<p>This document ships with the rack kits, and provides instructions for installing a server in a rack.</p>	Dell.com/Support/Manuals
System Information Label	<p>The system information label documents the system board layout and system jumper settings. Text is minimized due to space limitations and translation considerations. The label size is standardized across platforms.</p>	Inside the system chassis cover
QR code for system resources	<p>This code on the chassis can be scanned by a phone application to access additional information and resources for the server, including videos, reference materials, service tag information, and Dell contact information.</p>	Inside the system chassis cover
Enterprise Infrastructure Planning Tool (EIPT)	<p>The Dell online EIPT enables easier and more meaningful estimates to help you determine the most efficient configuration possible. Use EIPT to calculate the power consumption of your hardware, power infrastructure, and storage.</p>	Dell.com/calc

Appendix D: Service and support

Topics:

- [Default support levels](#)
- [ProDeploy Infrastructure Suite](#)
- [Supplemental Deployment Services](#)
- [Unique Deployment Scenarios](#)
- [DAY 2 - Automation Services with Ansible](#)
- [ProSupport Infrastructure Suite](#)
- [Specialty Support Services](#)
- [Consulting Services](#)
- [Resources](#)

Default support levels

Dell sales tools like DSA, OSC, Guided Journey, DellStar, and others are defaulted with standard configurations to make quoting easier. The system defaults for services for all MX-Series platforms are listed below:

1. **Support default:** 3 years, ProSupport Next Business Day (NBD) Onsite service which includes comprehensive 24x7 predictive and reactive support for hardware and software.
2. **Deployment default:** ProDeploy for MX-Series platforms which include onsite hardware installation and software configuration.

NOTE: Deployment of the MX-Series chassis enclosure (the metal frame) is included at no additional charge as part of the MX-Series deployment service for the sled. Optionally, the customer may choose any other factory or field deployment offers listed below.

ProDeploy Infrastructure Suite

ProDeploy Infrastructure Suite provides a variety of deployment offerings to satisfy a customer's unique needs. It is made up of five sub-offers: **Configuration Services**, **Rack Integration**, **Basic Deployment**, **ProDeploy**, and **ProDeploy Plus**.

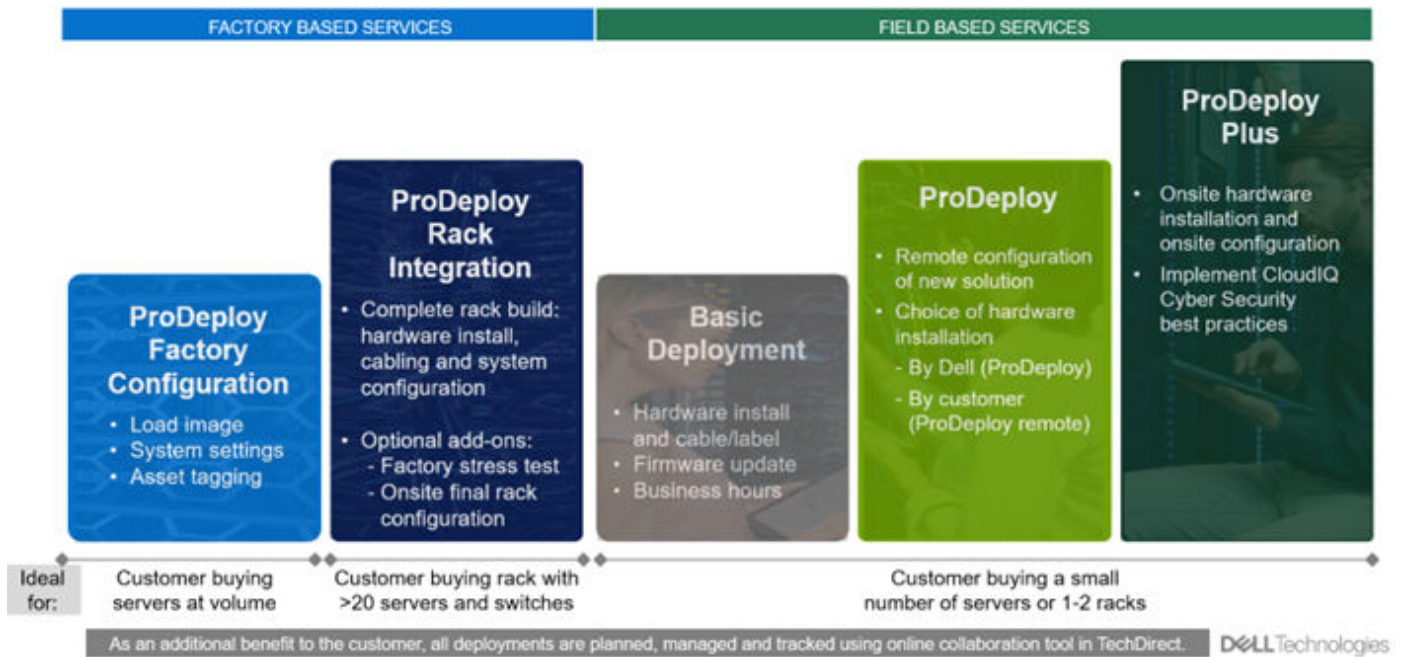

Figure 37. ProDeploy Infrastructure Suite

Factory Based Services

Pre-configured systems or complete racks, customized prior to shipping to the customer's site.

ProDeploy Factory Configuration

Ideal for customers buying servers in volume and seeking pre-configuration prior to shipping such as: custom image, system settings, and asset tagging so it arrives ready to use out of the box. Furthermore, servers are packaged and bundled to meet specific shipping and distribution requirements for each customer location to facilitate the rollout process. Once the server is onsite, Dell can install and configure the server to the environment using any of the field-based deployment services outlined in the next section.

ProDeploy Rack Integration

Ideal for customers seeking to build out fully integrated racks prior to shipping. These rack builds include hardware install, cabling, and full system configuration. You can also add-on a factory stress test and an optional on-site final rack configuration to complete the rack installation.

- STANDARD SKUs for Rack Integration is available in the USA only and requires:
 - 20 or more devices (R and C series servers, VxRail, and all Dell or non-Dell switches)
 - Use Informational SKUs for Dell switches or 3rd party products.
 - Shipping to contiguous USA
- USE CUSTOM QUOTE for Rack Integration scenarios that require:
 - Shipment to any country or region outside USA or shipping outside contiguous USA
 - Shipping to multiple locations
 - Racks containing less than 20 servers
 - Any rack that includes Storage

ProDeploy Infrastructure Suite | Factory based services

		ProDeploy Factory Configuration	ProDeploy Rack Integration ¹
Asset Configuration	Single point of contact for project management	•	•
	RAID, BIOS and iDRAC configuration	•	•
	Firmware freeze	•	•
	Asset Tagging and Reporting	•	•
	Customer system image	•	•
Deployment	Site readiness review and implementation planning	-	•
	Hardware racking and cabling	-	•
	Deployment verification, documentation, and knowledge transfer	•	•
Post-deployment	White glove logistics	-	•
	Onsite final configuration	-	-
	Install support software and connect with Dell Technologies	-	Optional
	Optional add on of Basic Deployment	Optional	-
Online collaboration	Online collaborative environment for planning, managing and tracking delivery	•	•

¹ Factory Rack Integration for server and VxRail; includes associated Dell network switches. 20-unit minimum requirement.

Figure 38. ProDeploy Infrastructure Suite - Factory services

Field-based Services

Put PowerEdge servers to work faster with Dell field-based deployment services. Whether we are deploying one server to one thousand – we have you covered. Dell provides versatile delivery options to fit every budget and operating model.

ProDeploy Plus

Elevate Infrastructure deployments with our most complete service from planning through onsite hardware installation and software configuration including the implementation of cybersecurity best practices. ProDeploy Plus provides the skill and scale needed to successfully execute demanding deployments in today's complex IT . The deployment starts with a site readiness review and implementation plan. Certified deployment experts perform the software configuration to include set up of leading operating systems and hypervisors. Dell will also configure PowerEdge software tools to include iDRAC and OpenManage system utilities as well as support AIOps platforms: MenvironmentsyService360, TechDirect, and CloudIQ. Unique to ProDeploy Plus, the cybersecurity implementation helps customers understand potential security risks and make recommendations for reducing product attack surfaces. The system is tested, validated prior to completion. The customer will also receive full project documentation and knowledge transfer to complete the process.

ProDeploy

ProDeploy provides remote software configuration and choice of hardware installation (onsite or guided). ProDeploy is great for customers who are price sensitive or willing to participate in some portion of the deployment to include providing remote access to their network. The ProDeploy remote software implementation includes everything mentioned in ProDeploy Plus except it does not include the added value, cybersecurity implementation and best practices.

Basic Deployment

Basic Deployment delivers worry-free professional installation by experienced technicians. This service is often sold to Competency Enabled Partners who will have Dell do the hardware installation while they complete the software configuration. Furthermore, Basic Deployment tends to be purchased by large enterprises who have smart technical staff. These companies just need Dell to install the hardware and they will perform the software configuration. The last use case for Basic Deployment is when paired with Factory Configuration services. The servers are pre-configured in the factory and the basic deployment service will install the system into the rack to finalize the deployment.

ProDeploy Infrastructure Suite | Field services

		Basic Deployment	ProDeploy	ProDeploy Plus
Pre-deployment	Single point of contact for project management	-	●	In region
	Site readiness review and implementation planning	-	●	●
Deployment	Deployment service hours	Business hours	24/7	24/7
	Hardware installation options	Onsite	Onsite or guided ¹	Onsite
	System software installation and configuration options	-	Remote	Onsite
	Install connectivity software based on Secure Connect Gateway technology ²	-	●	●
	Implement CloudIQ CyberSecurity best practices and policies	-	-	●
Post-deployment	Deployment verification, documentation and knowledge transfer	-	●	●
	Configuration data transfer to Dell technical support	-	●	●
Online collaboration	Online collaborative platform in TechDirect for planning, managing and tracking delivery	-	●	●

¹ Choose from onsite hardware installation or a guided option including project specific instructions, documentation and live expert guidance

² Post deployment use for intelligent, automated support & insights

Figure 39. ProDeploy Infrastructure Suite - Field services

Supplemental Deployment Services

Additional ways to expand scope or deploy for unique scenarios.

Table 66. Expand scope and transition

Expand scope and transition	Unique deployment scenarios
Two Host Adder (requires PD/PDP)	"Custom" Service Engagement
Additional Deployment Time (ADT) (Sold with or without PD/PDP)	ProDeploy Add-on for HPC
Data Migration	ProDeploy Plus for Direct Liquid Cooling (DLC 3000)
Residency Services (onsite or remote)	ProDeploy for TELCO
-	ProDeploy FLEX

Two Host Adder (requires PD/PDP)

Deploying new storage, compute, or networking devices may require interconnection to other servers (also called hosts). The Dell delivery team will set up four hosts per device as part of every ProDeploy service. For example, if the customer is buying two storage arrays the ProDeploy service will automatically include connectivity of four hosts each (4x2=8 total hosts per project since there are two devices). This supplemental "Two Host Adder" service provides for the configuration of additional hosts above what is already provided as part of the ProDeploy service. In many cases, customers can work with us while we set up the included hosts, so they may understand how to do the rest themselves. Always ask the customer how many hosts are being connected and sell the host adder depending on the customer's technology skillset. Note this service applies to the connectivity of Dell devices not 3rd party devices.

Additional Deployment Services (ADT) - sold with or without PD/PDP

You can expand the scope of a ProDeploy engagement leveraging Additional Deployment Time (ADT). ADT will cover additional tasks above the normal deliverables of the ProDeploy offers. ADT can also be used as a standalone service without ProDeploy.

SKUs are available for both Project Management and Technical Resource Expertise. SKUs are sold as blocks of four hours remote or eight hours onsite. The delivery team can assist in scoping the number of hours required for additional tasks.

Data Migration Services

Migrating data sets is no easy task. Our experts use proven tools and process to streamline data migrations and avoid compromising data. A customer project manager works with our experienced team of experts to create a migration plan. Data migration is part of every technology upgrade, platform change, and shift to the cloud. You can rely on Dell data migration services to perform a seamless transition.

Residency Services

Certified technical professionals act like an extension of your IT staff to enhance internal capabilities and resources and help you realize faster adoption and maximized ROI of new technology. Residency Services help customers transition to new capabilities quickly by leveraging specific technology skill sets. Residency experts can provide post implementation management and knowledge transfer that is related to a new technology acquisition or day-to-day operational management of the IT infrastructure.

- Global experts available to serve in-person (onsite) or virtual (remote)
- Engagements starting at 2 weeks with flexibility to adjust

Unique Deployment Scenarios

Custom Deployment Services

When a deployment is beyond the scope of the ProDeploy Infrastructure Suite, you can turn to the custom deployment services team to address complex implementation scenarios and unique customer requirements. The Dell custom deployment team is staffed with solution architects who assist with customer scoping calls to define the project and develop the statement of work. Custom services can handle a wide range of deployments that can be performed in the factory or onsite. All custom engagement services are requested through SFDC.

ProDeploy FLEX

ProDeploy Flex is a new service and a powerful tool for you to attach more services and improve revenue and margins. The ProDeploy Flex modular offer allows sales teams to build and better tailor services by mixing factory and field delivery options. You can also select special deployment scenarios without going to the custom order desk. FLEX is ideal for unique deployments where ProDeploy or ProDeploy Plus are not an adequate answer to the customer needs.

Key features of ProDeploy FLEX

- Build deployment quotes using modular, selectable features for both hardware and software.
- The system automatically scales pricing based on volume.
- Ideal for customers who require NativeEdge Orchestrator or edge deployments
- Ability to add deployment services to third-party networking devices

Deployment of HPC

High-Performance Computing (HPC) implementations require specialists that understand advanced feature sets. Dell deploys the world's fastest systems and understands the nuances that make them perform. HPC deployments are most often scoped as custom service engagements, however we can do smaller HPC clusters under 300 nodes using a standard ProDeploy SKU. Any standard SKU for HPC deployment will be sold as one base SKU per cluster (ProDeploy for HPC Base) along with one ProDeploy for HPC Add-on for each device in the cluster (server nodes and switches).

- Scope of ProDeploy for HPC: *Available as standard SKUs in the US and Canada. Custom Service would be required for all other regions.

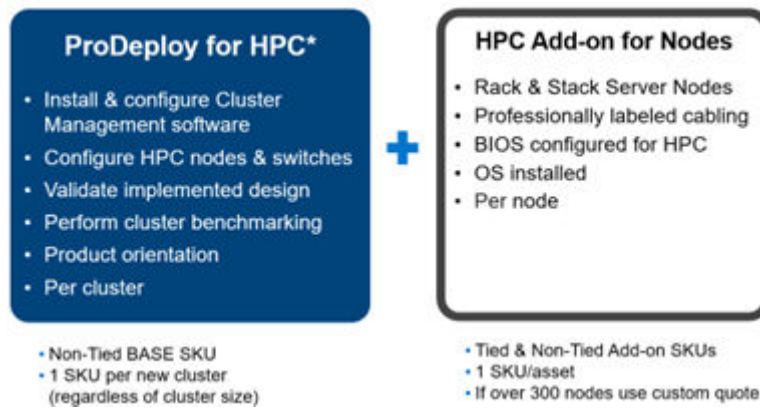

Figure 40. Standard deliverables of ProDeploy for HPC

Build HPC solutions for your unique requirements
 Choose ProDeploy for HPC or Custom deploy
 ProDeploy service includes configuration of most OS, cluster mgmt., networking and benchmarking



Figure 41. Visual view of HPC deployment options to include hardware and software

DAY 2 - Automation Services with Ansible

Dell solutions are built as "automation ready" with integrated APIs (Application Programming Interfaces) to allow customers to programmatically call actions on the product through code. Although Dell has published Ansible automation use cases, some customers need additional assistance with GitOps. By the end of the service, the customer will have the foundational components required to accelerate automation and understand how the programming works together: Day 1 and Day 2 use case automation scripts (ansible modules), CI/CD tool (Jenkins), and Version control (Git).

ProSupport Infrastructure Suite

ProSupport Infrastructure Suite is a set of support services that enable customers to build the solution that is right for their organization. They choose support models that are based on how they use technology and where they want to allocate resources. From the desktop to the data center, customers can address everyday IT challenges, such as unplanned downtime, mission-critical needs, data and asset protection, support planning, resource allocation, software application management and more. Optimize customer IT resources by choosing the right support model.

ProSupport Plus for Infrastructure

Service that caters to customers who require proactive, predictive, and personalized support for systems that manage critical business applications and workloads. When customers purchase PowerEdge server, we recommend ProSupport Plus,

our proactive and preventative support service for business-critical systems. ProSupport Plus provides all the benefits of ProSupport, including the following "Top five reasons to buy PSP".

1. Priority access to specialized support experts - immediate, advanced troubleshooting from an engineer that understands Dell infrastructure solutions.
2. Mission Critical Support – when critical (Severity 1) support issues happen, the customer is assured that we will do all we can to get them back up and running as quickly as possible.
3. Service Account Manager – a customer's #1 support advocate, ensuring they get the best possible proactive and predictive support experience.
4. Systems maintenance – on a semi-annual basis, we will keep a customer's ProSupport Plus system(s) up to date by installing the latest firmware, BIOS, and driver updates to improve performance and availability.
5. 3rd party software support – Dell is a customer's single point of accountability for any eligible 3rd party software installed on their ProSupport Plus system, whether they purchased the software from us or not.

ProSupport for Infrastructure

Comprehensive 24x7 support for hardware and software - best for production, but not critical, workloads and applications. The ProSupport service offers highly trained experts around the clock and around the globe to address IT needs. We help minimize disruptions and maximize availability of PowerEdge server workloads with:

- 24x7 support through phone, chat and online
- A central point of accountability for all hardware and software issues
- Hypervisor, operating system and application support
- Dell security advisories
- Onsite response service levels 4 hour or Next Business Day options
- Proactive issue detection with automated case creation
- Predictive hardware anomaly detection
- Incident Manager assigned for Severity 1 cases
- Collaborative third-party support
- Access to AIOps Platforms - (MyService360, TechDirect, and CloudIQ)
- Consistent experience regardless of where customers are located or what language they speak.

Basic Hardware Support

Provides reactive hardware support during normal business hours, excluding local national holidays. No software support or software related guidance. For improved levels of support choose ProSupport or ProSupport Plus.

ProSupport Infrastructure Suite | Enhanced value across all offers!

	Basic Hardware Support	ProSupport for Infrastructure	ProSupport Plus for Infrastructure	Changes with August 2023 release
Technical support availability and response objective	9/5, immediate	24/7, immediate	24/7, immediate	No change
Covered products	Hardware	Hardware & Software	Hardware & Software	No change
Onsite response service level	NBD	NBD or 4-hour	4-hour	ProSupport Plus NBD is retired
ProSupport AIOps platforms	•	•	•	MyService360 and TechDirect (all offers) CloudIQ (ProSupport & ProSupport Plus)
Dell Security Advisories	•	•	•	Available on additional products
Proactive issue detection with automated case creation	•	•	•	New to Basic
Predictive hardware anomaly detection		•	•	New to ProSupport
Access to software updates		•	•	No change
CloudIQ health and cybersecurity monitoring & analytics		•	•	Enhanced features
Incident Manager for Severity 1 cases		•	•	No change
Mission Critical support		•	•	Enhanced features
Priority access to remote senior support engineers ¹		•	•	No change
Service Account Manager		•	•	No change
Proactive system maintenance		•	•	No change
Limited 3 rd party software support ²		•	•	No change

¹Based on availability

²Software license can be purchased through Dell or BYOL - see Service Descriptions for details.

Dell Technologies

Figure 42. ProSupport Enterprise Suite

Specialty Support Services

Optional specialty support services complement the ProSupport Infrastructure Suite to provide additional proficiencies that are critical for modern data center operations.

Hardware coverage add-ons to ProSupport

- **Keep Your Hard Drive (KYHD) and Keep Your Component (KYC):** Normally if a device fails under warranty, Dell replaces it using a one-for-one exchange process. KYHD / KYC gives you the option to retain your device. It provides full control of sensitive data and minimizes security risk by letting you retain possession of failed drives / components when receiving replacement parts without incurring additional cost.
- **Onsite Diagnosis Service:** Ideal for sites with non-technical staff. Dell field technician performs initial troubleshooting diagnosis onsite and transfers to Dell remote engineers to resolve the issue.
- **ProSupport Add-on for HPC:** Sold as an add-on to a ProSupport service contract, the ProSupport Add-on for HPC provides solution-aware support to cover the additional requirements that are required to maintain an HPC environment such as:
 - Access to senior HPC experts
 - Advanced HPC cluster assistance: performance, interoperability, and configuration
 - Enhanced HPC solution level end-to-end support
 - Remote pre-support engagement with HPC Specialists during ProDeploy implementation
- **ProSupport Add-on for Telco (Respond & Restore):** An add-on service designed for the top 31 TELCO customers globally, Respond & Restore provides direct access to Dell solution experts who specialize in TELCO carrier-grade support. This add-on also provides a hardware uptime guarantee, meaning if a system fails, Dell will have it installed and operational within 4 hours for Severity 1 issues. Dell incurs penalties and fees if SLAs are not met.

Supplemental Site-wide Expertise

- **Multivendor Support Service:** Support your 3rd party devices as one service plan for servers, storage and networking (includes coverage for: Broadcom, Cisco, Fujitsu, HPE, Hitachi, Huawei, IBM, Lenovo, NetApp, Oracle, Quanta, SuperMicro & others).

- **Technical Account Manager:** Designated technology lead who monitors and manages performance and configuration of specific technology sets.
- **Designated Remote Support:** Personalized support expert who manages all troubleshooting and resolution of IT assets

Services for large enterprises

- **ProSupport One for Data Center:** ProSupport One for Data Center offers flexible site-wide support for large and distributed data centers with more than 1,000 assets (combined total of server, storage, networking, etc.). This offering is built on standard ProSupport features that leverage our global scale and are tailored to specific customer needs. While not for everyone, this service option offers a truly unique solution for our largest customers with the most complex environments.
 - Team of assigned Services Account Managers with remote or onsite options
 - Assigned technical and field engineers who are trained on the customer's environment and configurations
 - On-demand reporting and recommendations enabled by ProSupport AIOps tools (MyService360, TechDirect & CloudIQ)
 - Flexible onsite support and parts options that fit their operational model
 - A tailored support plan and training for their operations staff
- **Logistics Online Inventory Solution (LOIS):** Ideal for large organizations that have their own staff to support their data center. Dell offers a service called Logistics Online Inventory Solution which is an onsite parts locker that provides self-maintainers with a local inventory of common replacement components. Having access to these parts lockers allows the self-maintainer to replace a failed component immediately without delay. Each replacement part would automatically initiate a replenishment of the parts inventory that is shipped next day or delivered onsite by Dell during a regular scheduled visit (called Scheduled Onsite Service). As part of the LOIS system, customers can integrate their systems directly to Dell TechDirect using APIs to help streamline the support management process.

End-of-Life Services

- **Post Standard Support (PSS):** Extend service life beyond the initial seven years of ProSupport, adding up to five more additional years of hardware coverage
- **Data Sanitization & Data Destruction:** Renders data unrecoverable on repurposed or retired products, ensuring security of sensitive data and enabling compliance and provides NIST compliant certification.
- **Asset Recovery Services:** Recycle, resale, and disposal of hardware. Helps you securely and responsibly retire IT assets that are no longer needed while protecting both your business and the planet.

Consulting Services

Our expert consultants help customers transform faster, and quickly achieve business outcomes for the high value workloads Dell PowerEdge systems can handle. From strategy to full-scale implementation, Dell Technologies Consulting can help determine how to perform IT, workforce, or application transformation. We use prescriptive approaches and proven methodologies that are combined with portfolio and partner ecosystem of Dell Technologies to help achieve real business outcomes. We are here to help guide your next transformation that could address multi-cloud environments, business applications, DevOps, business resiliency, data center modernization, analytics, workforce collaboration, and user experiences.

Managed Services

Some customers prefer Dell to manage the complexity and risk of daily IT operations. Dell Managed Services utilizes proactive, artificial intelligence to improve operations and modern automation. This helps customers realize desired business outcomes from their infrastructure investments. With these technologies, our experts run, update, and fine-tune customer environments. You decide the service level requirements and we provide oversight of the environment. There are two types of managed service offers. First the outsourcing model, or CAPEX model, where Dell manages customer owned assets using our people and tools. The second is the "as-a-Service" model, or OPEX model, which we call APEX. In this service, Dell owns all technology and all the management of it. Many customers will have a blend of the two management types depending on the goals of the organization.

Managed	Outsourcing or CAPEX model	APEX	as-a-Service or OPEX model
<p>We manage your technology using our people and tools.¹</p> <ul style="list-style-type: none"> • Managed detection and response* • Technology Infrastructure • End-user (PC/desktop) • Service desk operations • Cloud Managed (Pub/Private) • Office365 or Microsoft Endpoint 		<p>We own all technology so you can off-load all IT decisions.</p> <ul style="list-style-type: none"> • APEX Cloud Services • APEX Flex on Demand elastic capacity • APEX Data Center Utility pay-per-use model 	

1 – Some minimum device counts may apply. Order via: ClientManagedServices.sales@dell.com

* Managed detection and response covers the security monitoring of laptops, servers, & virtual servers. Min. 50 devices combined. No Networking or Storage-only systems [SAN/NAS]. Available in 32 countries. [Details here](#)

Figure 43. Dell Managed Services

- **Managed Detection and Response (MDR):** Dell Technologies Managed Detection and Response (MDR) is powered by Secureworks Taegis XDR software platform. MDR is a managed service that secures the customer's IT environment against malicious actors and provides remediation if and when a threat is identified. When a customer purchases MDR, they will receive the following features from our team:
 - Dell badge resources
 - Agent rollout assistance to help deploy the Secureworks Endpoint Agent.
 - 24x7 threat detection and investigation
 - Up to 40 hrs per quarter of response and active remediation activities
 - If the customer experiences a breach, we will provide up to 40 hrs per year of Cyber incident response initiation.
 - Quarterly reviews with the customer to review the data

Education Services

Build the IT skills required to influence the transformational outcomes of the business. Enable talent and empower teams with the right skills to lead and perform transformational strategy that drives competitive advantage. Leverage the training and certification required for real transformation.

Dell Technologies Education Services offers PowerEdge server training and certifications that are designed to help customers achieve more from their hardware investment. The curriculum delivers the information and the practical, firsthand skills that their team must confidently install, configure, manage, and troubleshoot Dell servers.

To learn more or register for a class today, see Education.Dell.com

Resources

[Services for PowerEdge.](#)