

Dell PowerEdge R260

Technical Guide

Notes, cautions, and warnings

 **NOTE:** A NOTE indicates important information that helps you make better use of your product.

 **CAUTION:** A CAUTION indicates either potential damage to hardware or loss of data and tells you how to avoid the problem.

 **WARNING:** A WARNING indicates a potential for property damage, personal injury, or death.

Chapter 1: System overview	5
Key workloads.....	5
New technologies.....	5
Chapter 2: System features and generational comparison	7
Chapter 3: Chassis views and features	10
Front view of the system.....	10
Rear view of the system.....	11
Inside the system.....	15
Chapter 4: Processor	21
Processor features	21
Supported processors.....	21
Chapter 5: Memory subsystem	23
Supported memory.....	23
Chapter 6: Storage	24
Storage controllers.....	24
Storage controller feature matrix.....	24
Supported Drives.....	25
Internal storage configuration.....	26
External Storage.....	26
Chapter 7: Networking	27
Overview.....	27
Supported network cards	27
Chapter 8: PCIe subsystem	28
PCIe risers.....	28
Chapter 9: Power, thermal, and acoustics	30
Power.....	30
Power Supply Units.....	31
Thermal.....	31
Thermal design.....	32
Acoustics.....	33
Acoustical performance.....	33
Chapter 10: Rack, rails, and cable management	35
Rack Rails.....	35

Chapter 11: Operating Systems and Virtualization.....	38
Supported Operating Systems.....	38
Chapter 12: Dell Systems Management.....	39
Integrated Dell Remote Access Controller (iDRAC).....	39
Systems Management software support matrix.....	40
Chapter 13: Appendix D: Service and support.....	42
Why attach service contracts.....	42
ProSupport Infrastructure Suite	42
Specialty Support Services.....	44
ProDeploy Infrastructure Suite.....	45
Supplemental Deployment Services	48
Unique Deployment Scenarios.....	49
DAY 2 – Automation Services with Ansible.....	49
Dell Technologies Consulting Services.....	50
Chapter 14: Appendix A: Additional specifications.....	52
Chassis dimensions	52
System weight.....	53
NIC port specifications.....	53
Video specifications.....	53
USB Ports.....	55
PSU rating.....	56
Environmental specifications.....	57
Particulate and gaseous contamination specifications.....	58
Thermal restriction matrix.....	59
Thermal air restrictions.....	60
Chapter 15: Appendix A. Standards compliance.....	61
Chapter 16: Appendix C Additional resources.....	62

System overview

The Dell™ PowerEdge R260 is a powerful entry-level one-socket rack server designed to meet the evolving computing demands from organizations.

The system features:

- One Intel® Xeon® 6300 series or one Xeon® E-2400 series processor or one Intel® Pentium® processor
- Four DDR5 UDIMM slots
- One non cabled AC or DC power supply unit or One cabled AC power supply unit
- PCI Express® (PCIe) 4.0 enabled expansion slots
- Up to 6 x 2.5-inch SAS/SATA or up to 4 x 2.5-inch SATA drives or up to 2 x 3.5-inch SAS/SATA drives
- Onboard LAN ports

NOTE: The Dell PowerEdge R260 system supports speeds of 12 Gbps for SAS3 and 6 Gbps for SATA. The drive speed is determined by the controller's capability.

Topics:

- [Key workloads](#)
- [New technologies](#)

Key workloads

PowerEdge R260 is versatile enough to address many customer segments and workloads that include:

- Mailing and Message
- Data analytics
- Traditional Business Applications
- Non-data center application

New technologies

Table 1. New technologies

Technology	Detailed Description
Intel® Xeon® 6300 series processor/ Intel® Xeon® E-2400 series processor	Core count: Up to eight core processor
	Maximum number of PCIe lanes: Integrated 16 PCIe Gen5 lanes @ 32 GT/s, 4 PCIe Gen4 lanes @ 16 GT/s
	Maximum TDP: 95 W
Intel® Pentium® G7400/ G7400T processor	Core count: Up to two core processor
	Maximum number of PCIe lanes: Integrated 16 PCIe Gen5 lanes @ 32 GT/s, 4 PCIe Gen4 lanes @ 16 GT/s
	Maximum TDP: 46 W
5600 MT/s DDR5 Memory	Maximum 4 DIMM slots per system
	Supports DDR5 ECC UDIMM up to 4400 MT/s NOTE: Operating speed of the DIMM is limited due to the processor.
Flex I/O	LOM, 2 x 1Gb with BCM5720 LAN controller

Table 1. New technologies (continued)

Technology	Detailed Description
	Rear I/O with: <ul style="list-style-type: none"> ● 1 x Dedicated iDRAC Ethernet port ● 1 x USB 3.0 ● 1 x USB 2.0 ● 1 x VGA port ● 1 x Serial port Front I/O with: <ul style="list-style-type: none"> ● 1 x USB 2.0 ● 1 x Dedicated iDRAC Direct micro-USB
CPLD 1-wire	Support payload data of Riser, BOSS-N1, BP, and Rear I/O to BIOS and iDRAC
Dedicated PERC	PERC 11 <ul style="list-style-type: none"> ● PERC H355, PERC H755
Power Supplies	60 mm dimension is the new PSU form factor design.
	700 W mixed mode HLAC Titanium
	106 mm form factor
	450 W WRAC Platinum (AC only)

 **NOTE:** WRAC - Wide Range AC 100 VAC - 240 VAC

 **NOTE:** HLAC - High Line AC 200 VAC - 240 VAC

System features and generational comparison

The following table shows the comparison between the PowerEdge R260 with the PowerEdge R250.

Table 2. Features comparison



Features	PowerEdge R260	PowerEdge R250
Processors	One Intel® Xeon® 6300 series or one Xeon® E-2400 series processor with up to 8 cores or one Intel® Pentium® processor with up to 2 cores	One Intel® Xeon® E-2300 series processor with up to 8 cores per processor
Memory	Up to 4 x DDR5 ECC UDIMMs DIMM Speed: Up to 4400 MT/s  NOTE: Operating speed of the DIMM is limited due to the processor.	Up to 4 x DDR4 UDIMMs DIMM Speed: Up to 3200 MT/s
Storage Controllers	Internal Controllers: PERC H355, PERC H755, HBA355i	Internal Controllers: PERC H345, PERC H355, PERC H755, HBA355i
	External Controllers: HBA355e	External Controllers: HBA355e
	BOSS-N1	BOSS-S1
	Software RAID: S160 SATA	Software RAID: S150 SATA
Drive Bays	Front: Up to 2 x 3.5-inch SAS/SATA (HDD) Up to 6 x 2.5-inch SAS/SATA (HDD/SSD)	Front: Up to 4 x 3.5-inch SAS/SATA (HDD/SSD) Up to 2 x 3.5-inch SAS/SATA (HDD/SSD)
Power Supplies	450 W Platinum 100 V-240 V AC, cabled non redundant 700 W Mixed Mode Titanium 200 V-240 V AC or 240 V DC, non cabled	450 W Bronze 100-240 V AC, cabled 450 W Platinum 100-240 V AC, cabled 700 W Mixed Mode Titanium 200 V-240 V AC or 240 V DC, non cabled
Cooling Options	Air cooled	Air cooled
Fans	Up to Five Standard (STD) fans and One optional High Performance (HPR) fan.  NOTE: All fans are cabled.	Up to Three Standard (STD) fans and One optional High Performance (HPR) fan.  NOTE: All fans are cabled.
Dimension	Height : 42.8 mm (1.68 inches)	Height : 42.8 mm (1.68 inches)
	Width : 482.0 mm (18.97 inches)	Width : 482.0 mm (18.97 inches)
	Depth: 461.14 mm (18.15 inches) without bezel	Depth: 585 mm (23.02 inches) without bezel
	Depth : 496.8 mm (19.55 inches) with bezel	Depth: 598.64 mm (23.56 inches) with bezel
	Depth - 426.6 mm (16.80 inches) with cable PSU and without bezel	
Form Factor	1U	1U
Embedded Management	<ul style="list-style-type: none"> iDRAC9 	<ul style="list-style-type: none"> iDRAC9 Enterprise

Table 2. Features comparison (continued)

Features	PowerEdge R260	PowerEdge R250				
	<ul style="list-style-type: none"> • iDRAC Direct • iDRAC RESTful API with Redfish • iDRAC Service Manual 	<ul style="list-style-type: none"> • iDRAC Direct, Datacenter license options • iDRAC RESTful API with Redfish • iDRAC Service Module 				
Bezel	Security bezel or Optional Filter bezel	Optional LCD bezel or security bezel				
OpenManage Software	<ul style="list-style-type: none"> • OpenManage Enterprise • OpenManage Power Manager plugin • OpenManage Service plugin • OpenManage Update Manager plugin • CloudIQ for PowerEdge plug in • OpenManage Enterprise Integration for VMware vCenter • OpenManage Integration for Microsoft System Center • OpenManage Integration with Windows Admin Center 	<ul style="list-style-type: none"> • OpenManage Enterprise • OpenManage Power Manager plugin • OpenManage SupportAssist plugin • OpenManage Update Manager plugin 				
Mobility	OpenManage Mobile	OpenManage Mobile				
Integrations and Connections	OpenManage Integrations <ul style="list-style-type: none"> • BMC Truesight • Microsoft System Center • OpenManage Integration with ServiceNow • Red Hat Ansible Modules • Terraform Providers • VMware vCenter and vRealize Operations Manager 	<table border="1"> <tr> <td> Integrations: <ul style="list-style-type: none"> • Microsoft® System Center • VMware® vCenter™ and vRealize Operations Manager • BMC Truesight • Red Hat Ansible Modules </td> <td> Connections: <ul style="list-style-type: none"> • Nagios Core & Nagios XI • Micro Focus Operations Manager i (OMi) • IBM Tivoli Netcool/OMNIbus • IBM Tivoli® Network Manager IP Edition </td> </tr> </table>	Integrations: <ul style="list-style-type: none"> • Microsoft® System Center • VMware® vCenter™ and vRealize Operations Manager • BMC Truesight • Red Hat Ansible Modules 	Connections: <ul style="list-style-type: none"> • Nagios Core & Nagios XI • Micro Focus Operations Manager i (OMi) • IBM Tivoli Netcool/OMNIbus • IBM Tivoli® Network Manager IP Edition 		
Integrations: <ul style="list-style-type: none"> • Microsoft® System Center • VMware® vCenter™ and vRealize Operations Manager • BMC Truesight • Red Hat Ansible Modules 	Connections: <ul style="list-style-type: none"> • Nagios Core & Nagios XI • Micro Focus Operations Manager i (OMi) • IBM Tivoli Netcool/OMNIbus • IBM Tivoli® Network Manager IP Edition 					
Security	<ul style="list-style-type: none"> • Cryptographically signed firmware • Data at Rest Encryption (SEDs with local or external key mgmt) • Secure Boot • Secured Component Verification (Hardware integrity check) • Secure Erase • Secured-core server • Silicon Root of Trust • System Lockdown (requires iDRAC9 Enterprise or Datacenter) • TPM 2.0 FIPS, CC-TCG certified, TPM 2.0 China NationZ 	<ul style="list-style-type: none"> • TPM 1.2/2.0 FIPS, CC-TCG certified, TCM 2.0 optional • Cryptographically signed firmware • Silicon Root of Trust • Secure Boot • System Lockdown (requires iDRAC9 Enterprise or Datacenter) • Secure Erase 				
Embedded NIC	2 x 1GbE LOM	2 x 1 GbE LOM				
Networking Options	Optional Network Card	Optional Network Card				
GPU Options	None	None				
Ports	<table border="1"> <tr> <td> Front Ports: <ul style="list-style-type: none"> • 1 x USB 2.0 • 1 x iDRAC Direct (Micro - AB USB) port </td> <td> Rear Ports: <ul style="list-style-type: none"> • 1 x USB 3.2 Gen1 • 1 x USB 2.0 • 1 x VGA port • 1 x Serial Port • 1 x Dedicated iDRAC port • Ethernet port </td> </tr> </table>	Front Ports: <ul style="list-style-type: none"> • 1 x USB 2.0 • 1 x iDRAC Direct (Micro - AB USB) port 	Rear Ports: <ul style="list-style-type: none"> • 1 x USB 3.2 Gen1 • 1 x USB 2.0 • 1 x VGA port • 1 x Serial Port • 1 x Dedicated iDRAC port • Ethernet port 	<table border="1"> <tr> <td> Front Ports: <ul style="list-style-type: none"> • 1 x USB 2.0 • 1 x iDRAC Direct (Micro - AB USB) port </td> <td> Rear Ports: <ul style="list-style-type: none"> • 1 x USB 3.0 • 1 x USB 2.0 • 1 x VGA port • 1 x Serial Port • 1 x Dedicated iDRAC port • Ethernet port • 2 x Ethernet port </td> </tr> </table>	Front Ports: <ul style="list-style-type: none"> • 1 x USB 2.0 • 1 x iDRAC Direct (Micro - AB USB) port 	Rear Ports: <ul style="list-style-type: none"> • 1 x USB 3.0 • 1 x USB 2.0 • 1 x VGA port • 1 x Serial Port • 1 x Dedicated iDRAC port • Ethernet port • 2 x Ethernet port
Front Ports: <ul style="list-style-type: none"> • 1 x USB 2.0 • 1 x iDRAC Direct (Micro - AB USB) port 	Rear Ports: <ul style="list-style-type: none"> • 1 x USB 3.2 Gen1 • 1 x USB 2.0 • 1 x VGA port • 1 x Serial Port • 1 x Dedicated iDRAC port • Ethernet port 					
Front Ports: <ul style="list-style-type: none"> • 1 x USB 2.0 • 1 x iDRAC Direct (Micro - AB USB) port 	Rear Ports: <ul style="list-style-type: none"> • 1 x USB 3.0 • 1 x USB 2.0 • 1 x VGA port • 1 x Serial Port • 1 x Dedicated iDRAC port • Ethernet port • 2 x Ethernet port 					

Table 2. Features comparison (continued)

Features	PowerEdge R260	PowerEdge R250
	<ul style="list-style-type: none"> • 2 x Ethernet port 	
	Internal : <ul style="list-style-type: none"> • 1 x USB 3.2 Gen1 	Internal : <ul style="list-style-type: none"> • 1 x USB 3.0 (optional)
PCIe	Up to 2 x PCIe Slots Gen4 on Riser	Up to 2 x PCIe Slots Gen4
Operating System and Hypervisors	<ul style="list-style-type: none"> • Canonical Ubuntu Server LTS • Microsoft Windows Server with Hyper-V • Red Hat Enterprise Linux • SUSE Linux Enterprise Server • VMware ESXi For specifications and interoperability details, see OS support .	<ul style="list-style-type: none"> • Canonical® Ubuntu® LTS • Citrix® Hypervisor • Microsoft® Windows Server® LTSC with Hyper-V • Red Hat® Enterprise Linux • SUSE® Linux Enterprise Server For specifications and interoperability details, see Dell.com/OSsupport

Chassis views and features

Topics:

- Front view of the system
- Rear view of the system
- Inside the system

Front view of the system



Figure 1. Front view of 2 x 3.5-inch drive system

Table 3. Features are available on the front of the system for a 3.5-inch drive system

Item	Ports, panels, and slots	Icon	Description
1	Left control panel	N/A	Contains the system health, system ID, and the status LED indicator.
2	3.5-inch drives	NA	Enables you to install drives that are supported on your system. .
3	Right control panel	N/A	Contains the Power button, USB 2.0 port and iDRAC direct Micro USB port



Figure 2. Front view of 6 x 2.5-inch drive system

Table 4. Features are available on the front of the system for a 2.5-inch drive system

Item	Ports, panels, and slots	Icon	Description
1	Left control panel	N/A	Contains the system health, system ID, and the status LED indicator.
2	2.5-inch drives	NA	Enables you to install drives that are supported on your system. .
3	Right control panel	N/A	Contains the Power button, USB 2.0 port and iDRAC direct Micro USB port

Rear view of the system

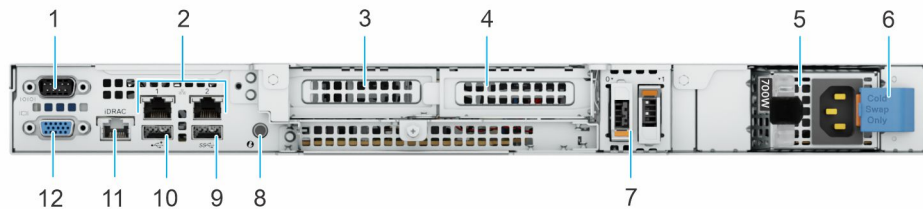





Figure 3. Rear view of the system with non-cabled PSU

Table 5. Features available on the rear of the system

Item	Ports, panels, or slots	Icon	Description
1	Serial port	10101	Enables you to connect a serial device to the system.
2	NIC ports		The NIC ports that are integrated on the system board provide network connectivity.
3	PCIe expansion riser card slot 1	N/A	The expansion card riser enables you to connect PCI Express expansion cards. For more information, see the Expansion card installation guidelines section.
4	PCIe expansion riser card slot 2	N/A	The expansion card riser enables you to connect PCI Express expansion cards. For more information, see the Expansion card installation guidelines section.
5	Power supply unit , non-cabled (PSU)		Indicates the PSU.
6	PSU lock for non-cabled PSU	N/A	Lock needs to be removed to take out the PSU

Table 5. Features available on the rear of the system (continued)

Item	Ports, panels, or slots	Icon	Description
7	BOSS-N1 module	N/A	BOSS-N1 module for internal system boot.
8	System Identification (ID) button		<p>The System Identification (ID) button is available on the front and back of the system. Press the button to identify a system in a rack by turning on the system ID button. You can also use the system ID button to reset iDRAC and to access BIOS using the step through mode. When pressed, the system ID LED in the back panel blinks until either the front or rear button is pressed again. Press the button to toggle between on or off mode.</p> <p>i NOTE: If the server stops responding during POST, press and hold the System ID button for more than five seconds to enter the BIOS progress mode</p> <p>i NOTE: To reset the iDRAC (if not disabled on the iDRAC setup page by pressing F2 during system boot), press and hold the System ID button for more than 15 seconds.</p>
9	USB 3.2 Gen1 port		This port is USB 3.2 Gen1-compliant.
10	USB 2.0 port		This port is USB 2.0-compliant.
11	Dedicated iDRAC Ethernet port	iDRAC	Enables you to remotely access iDRAC. For more information, see the <i>Integrated Dell Remote Access Controller User's Guide</i> at PowerEdge Manuals .
12	VGA port		Enables you to connect a display device to the system.

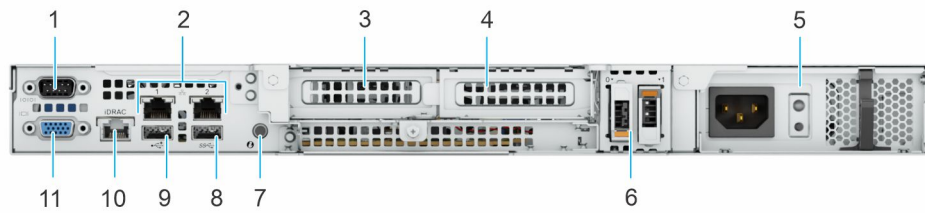





Figure 4. Rear view of the system with cabled PSU

Table 6. Features available on the rear of the system

Item	Ports, panels, or slots	Icon	Description
1	Serial port		Enables you to connect a serial device to the system.
2	NIC ports		The NIC ports that are integrated on the system board provide network connectivity.
3	PCIe expansion riser card slot 1	N/A	The expansion card riser enables you to connect PCI Express expansion cards. For more information, see the Expansion card installation guidelines section.
4	PCIe expansion riser card slot 2	N/A	The expansion card riser enables you to connect PCI Express expansion cards. For more information, see the Expansion card installation guidelines section.
5	Power supply unit , cabled (PSU)		Indicates the PSU.
6	BOSS-N1 module	N/A	BOSS-N1 module for internal system boot.
7	System Identification (ID) button		<p>The System Identification (ID) button is available on the front and back of the system. Press the button to identify a system in a rack by turning on the system ID button. You can also use the system ID button to reset iDRAC and to access BIOS using the step through mode. When pressed, the system ID LED in the back panel blinks until either the front or rear button is pressed again. Press the button to toggle between on or off mode.</p> <p>i NOTE: If the server stops responding during POST, press and hold the System ID button for</p>

Table 6. Features available on the rear of the system (continued)

Item	Ports, panels, or slots	Icon	Description
			<p>more than five seconds to enter the BIOS progress mode</p> <p>i NOTE: To reset the iDRAC (if not disabled on the iDRAC setup page by pressing F2 during system boot), press and hold the System ID button for more than 15 seconds.</p>
8	USB 3.2 Gen1 port		This port is USB 3.2 Gen1-compliant.
9	USB 2.0 port		This port is USB 2.0-compliant.
10	Dedicated iDRAC Ethernet port	iDRAC	Enables you to remotely access iDRAC. For more information, see the Integrated Dell Remote Access Controller User's Guide at PowerEdge Manuals .
11	VGA port		Enables you to connect a display device to the system.

Inside the system

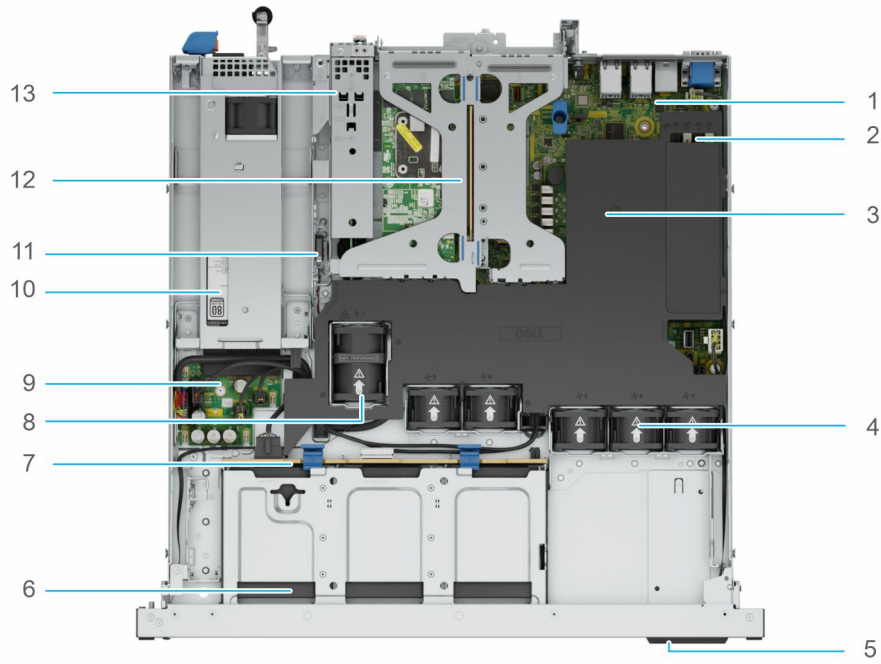

Figure 5. Inside view of the system with non-cabled PSU and 2.5 inch drives with air shroud and riser

- 1. System board
- 2. DIMM slots
- 3. Air shroud
- 4. Standard (STD) cooling fans
- 5. Express Service Code Tag
- 6. Front drives
- 7. Drive backplane
- 8. High Performance (HPR) fan - Optional
- 9. Power Interposer board (PIB)
- 10. Power supply unit (non-cabled)
- 11. Intrusion switch
- 12. Butterfly Riser with 2x PCIe slots
- 13. BOSS N1 module

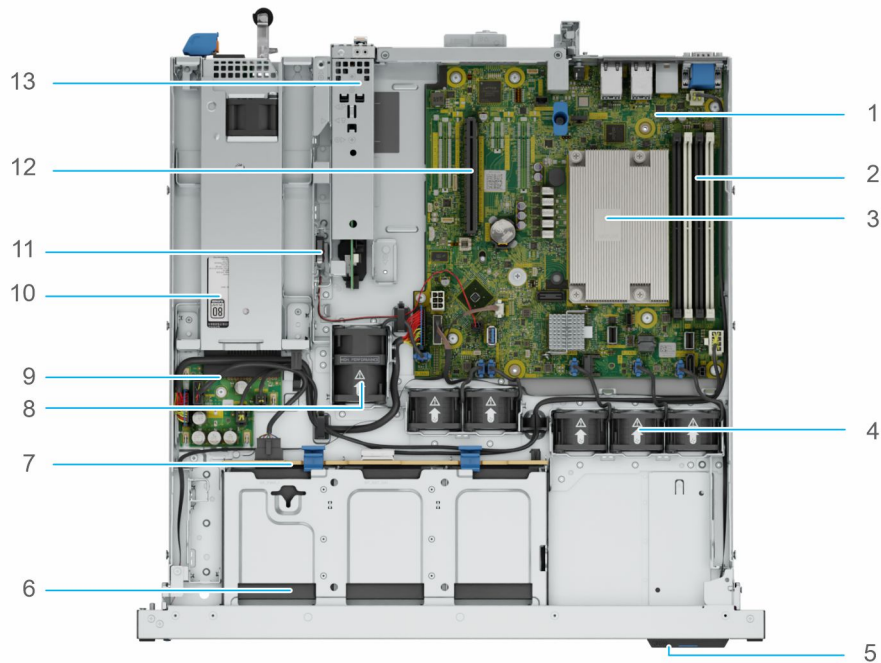

Figure 6. Inside view of the system with non-cabled PSU and 2.5 inch drives without air shroud and riser

1. System board
2. DIMM slots
3. Processor heatsink
4. Standard (STD) cooling fans
5. Express Service Code Tag
6. Front drives
7. Drive backplane
8. High Performance (HPR) fan - Optional
9. Power Interposer board (PIB)
10. Power supply unit (non-cabled)
11. Intrusion switch
12. PCIe riser slot
13. BOSS N1 module

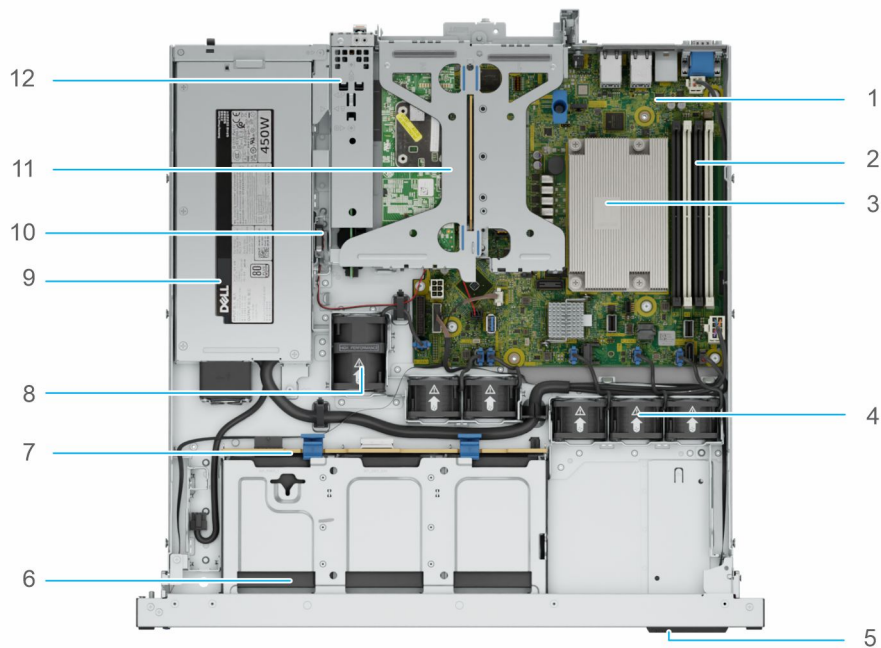

Figure 7. Inside view of the system with cabled PSU and 2.5 inch drives without air shroud

1. System board
2. DIMM slots
3. Processor heatsink
4. Standard (STD) cooling fans
5. Express Service Code Tag
6. Front drives
7. Drive backplane
8. High Performance (HPR) fan - Optional
9. Power supply unit (cabled)
10. Intrusion switch
11. Butterfly Riser with 2x PCIe slots
12. BOSS N1 module

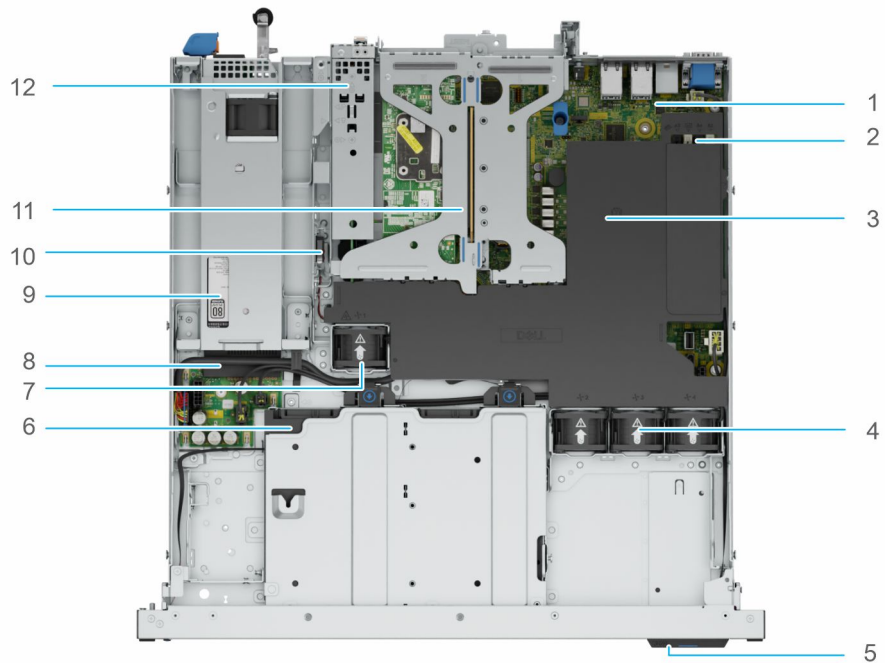

Figure 8. Inside view of the system with non-cabled PSU and 3.5 inch drives with air shroud and riser

- | | |
|--|---------------------------------|
| 1. System board | 2. DIMM slots |
| 3. Air shroud | 4. Standard (STD) cooling fans |
| 5. Express Service Code Tag | 6. Front drives |
| 7. Standard (STD) cooling fan | 8. Power Interposer board (PIB) |
| 9. Power supply unit (non-cabled) | 10. Intrusion switch |
| 11. Butterfly Riser with 2x PCIe slots | 12. BOSS N1 module |

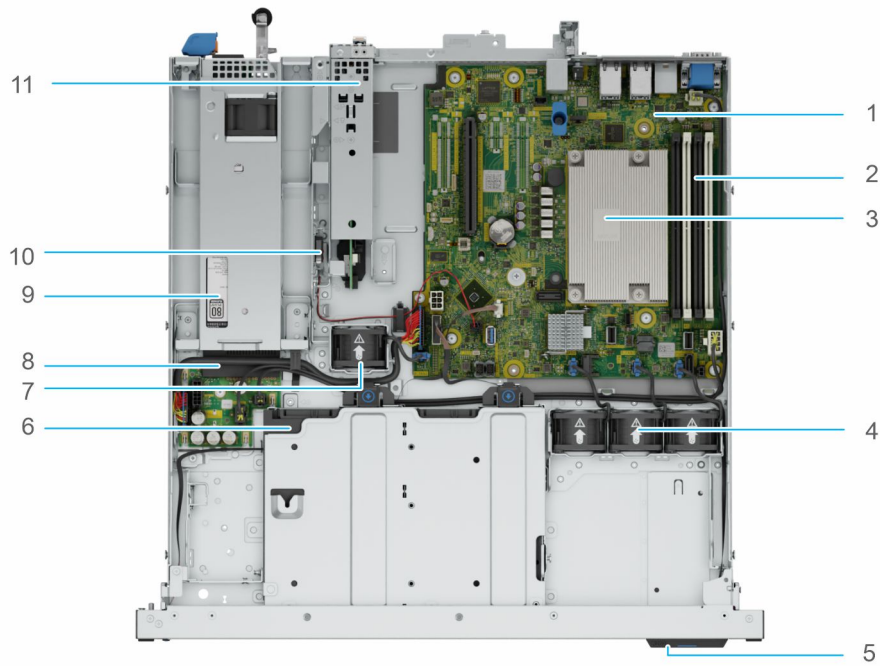

Figure 9. Inside view of the system with non-cabled PSU and 3.5 inch drives with air shroud and riser

- 1. System board
- 2. DIMM slots
- 3. Processor heatsink
- 4. Standard (STD) cooling fans
- 5. Express Service Code Tag
- 6. Front drives
- 7. Standard (STD) cooling fan
- 8. Power Interposer board (PIB)
- 9. Power supply unit (non-cabled)
- 10. Intrusion switch
- 11. PCIe riser slot
- 12. BOSS N1 module

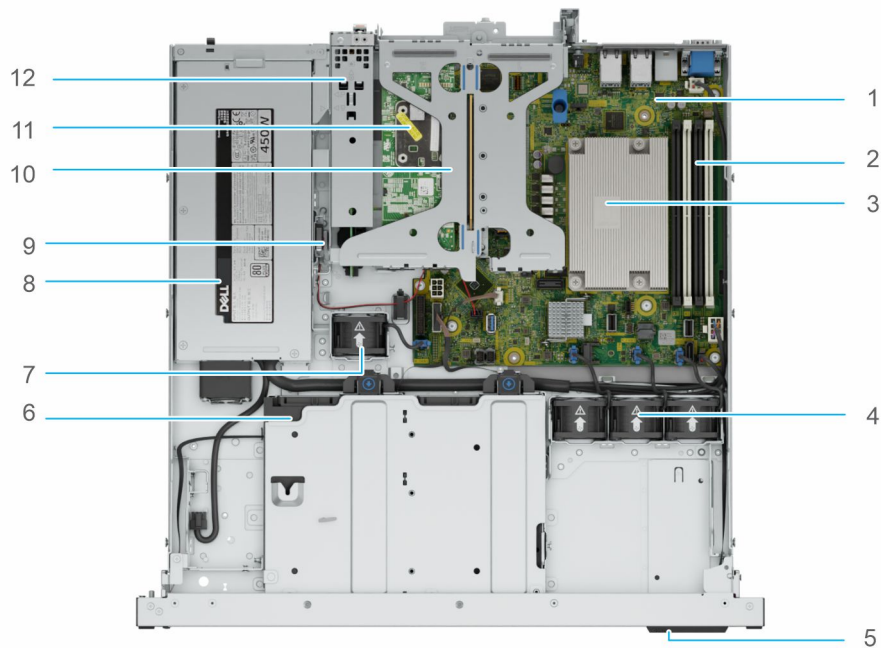

Figure 10. Inside view of the system with cabled PSU and 3.5 inch drives without air shroud

- | | |
|-------------------------------|--|
| 1. System board | 2. DIMM slots |
| 3. Processor heatsink | 4. Standard (STD) cooling fans |
| 5. Express Service Code Tag | 6. Front drives |
| 7. Standard (STD) cooling fan | 8. Power supply unit (cabled) |
| 9. Intrusion switch | 10. Butterfly Riser with 2x PCIe slots |
| 11. BOSS N1 module | |

Processor

Topics:

- [Processor features](#)

Processor features

The following lists the features and functions that are in the upcoming Intel® Xeon® 6300 series Processor offering:

- For small businesses, the Xeon® 6300 series provides a reliable solution with for business ready servers to support business-critical services and customer data needs.
- For cloud service, the Xeon® 6300 series is the perfect option for Bare Metal Instances and Code/Data Security, with a cost-effective solution for essential performance to support entry-level bare metal services.

Key updates for the 6300 series include increased performance with a new processor core architecture:

- 4, 6, and 8 core option
- Up to 95 W TDP
- Up to 128 GB memory
- DDR5 up to 4800 MT/s

Supported processors

Table 7. Supported processors for PowerEdge R260

Processor	Clock Speed (GHz)	Cache (M)	Cores	Threads	Turbo	Memory Speed (MT/s)	Memory Capacity	TDP
6369P	3.3	24	8	16	Turbo	4800	128 GB	95 W
6357P	3.0	24	8	16	Turbo	4800	128 GB	80 W
6353P	2.7	24	8	16	Turbo	4800	128 GB	65 W
6349P	3.6	18	6	12	Turbo	4800	128 GB	95 W
6337P	3.5	18	6	12	Turbo	4800	128 GB	80 W
6333P	3.1	18	6	12	Turbo	4800	128 GB	65 W
6325P	3.5	12	4	8	Turbo	4800	128 GB	55 W
6315P	2.8	12	4	4	Turbo	4800	128 GB	55 W
E-2488	3.2	24	8	16	Turbo	4800	128 GB	95 W
E-2486	3.5	18	6	12	Turbo	4800	128 GB	95 W
E-2478	2.8	24	8	16	Turbo	4800	128 GB	80 W
E-2468	2.6	24	8	16	Turbo	4800	128 GB	65 W
E-2456	3.3	18	6	12	Turbo	4800	128 GB	80 W
E-2436	2.9	18	6	12	Turbo	4800	128 GB	65 W
E-2434	3.4	12	4	8	Turbo	4800	128 GB	55 W

Table 7. Supported processors for PowerEdge R260 (continued)

Processor	Clock Speed (GHz)	Cache (M)	Cores	Threads	Turbo	Memory Speed (MT/s)	Memory Capacity	TDP
E-2414	2.6	12	4	4	Turbo	4800	128 GB	55 W
G7400	3.7	6	2	4	No Turbo	4800	128 GB	46 W
G7400T	3.1	6	2	4	No Turbo	4800	128 GB	35 W

Memory subsystem

Topics:

- Supported memory

Supported memory

Table 8. Memory technology

DIMM type	Rank	Capacity	DIMM rated voltage and speed	Operating Speed	
				1 DIMM per channel (DPC)	2 DIMM per channel (DPC)
ECC UDIMM	1 R	16 GB	DDR5 (1.1 V), 5600 MT/s	4400 MT/s	4000 MT/s
	2 R	32 GB	DDR5 (1.1 V), 5600 MT/s	4400 MT/s	3600 MT/s

The following table lists the supported DIMMs for R260.

Table 9. Supported DIMMs

Rated DIMM Speed (MT/s)	DIMM Type	DIMM Capacity (GB)	Ranks per DIMM	Data Width	DIMM Volts
5600	UDIMM	16	1	8	1.1
5600	UDIMM	32	2	8	1.1

Storage

Topics:

- Storage controllers
- Supported Drives
- Internal storage configuration
- External Storage

Storage controllers

NOTE: The size of the RAID 1 drives must be less than that of the second RAID container.

Dell's RAID controller options offer performance improvements, including the Adapter PERC solution. Adapter PERC provides a base RAID HW controller without consuming a PCIe slot by using a small form factor and high-density connector to the base planar.

Table 10. PERC Series controller offerings

Performance Level	Controller and Description
Entry	S160 - Software RAID SATA
Value	HBA355 Adapter (Internal/external) , H355 Adapter
Performance	H755 Adapter

NOTE: For more information about the features of the Dell PowerEdge RAID controllers (PERC), Software RAID controllers, or BOSS card, and on deploying the cards, see the storage controller documentation at [Storage Controllers Manuals](#).

NOTE: H355 will replace H345 as the entry raid controller.

Storage controller feature matrix

Table 11. Storage controller feature matrix

Model and Form Factors	Interface Support	PCI Support	SAS Connection	Cache Memory Size	Write Back Cache	RAID Levels	Max Drive Support	RAID Support
PowerEdge Server-Storage Controllers (PERC and SAS HBA) Series 11								
H755 Adapter	12Gb/s SAS 6Gb/s SAS/SATA 3Gb/s SAS/SATA Gen3 (8 GT/s) NVMe Gen4 (16 GT/s) NVMe	PCIe Gen 4	16 ports- 2x8 Internal	8 GB NV	Flash Backed Cache	0,1,5,6,10,50,60	16/ controller 50 with SAS Expander	Hardware

Table 11. Storage controller feature matrix (continued)

Model and Form Factors	Interface Support	PCI Support	SAS Connection	Cache Memory Size	Write Back Cache	RAID Levels	Max Drive Support	RAID Support
HBA355i Adapter	12Gb/s SAS 6Gb/s SAS/SATA 3Gb/s SAS/SATA	PCIe Gen 4	16 ports- 2x8 Internal	N/A	N/A	N/A	16/ controller 50 with SAS Expander	N/A
HBA355e Adapter	12Gb/s SAS 6Gb/s SAS/SATA 3Gb/s SAS/SATA	PCIe Gen 4	16 ports- 4x4 external	N/A	N/A	N/A	240	N/A
H355 Adapter	12Gb/s SAS 6Gb/s SAS/SATA	PCIe Gen 4	16 ports- 2x8 Internal	No Cache	No Cache	0,1,10	Up to 32 RAID, or 32 Non- RAID	Hardware
S160 Software RAID	Gen4 (16 GT/s) NVMe	PCIe Gen 4	N/A	No Cache	No Cache	0,1,5,10	Up to 8	Software RAID - Windows only

NOTE:

1. RAID 5/50 removed from entry RAID card
2. SWRAID support for Linux provides a pre-boot configuration utility to configure MDRAID and degraded boot capability.
3. For information, post-RTS, see the Storage controller documentation at [Storage Controller Manuals](#).

This document is updated as changes happen, so for the latest version be sure to bookmark it rather than downloading an offline copy or refer to the [Storage Controller Matrix](#) on sales portal.

Internal storage configuration

PowerEdge R260 supports the following internal storage configurations:

- 6 x 2.5-inch SAS/SATA RAID
- 2 x 3.5-inch SAS/SATA RAID
- 4 x 2.5-inch SATA SWRAID

NOTE: The PowerEdge R260 system does not support rear storage.

Supported Drives

The table shown below lists the internal drives supported by the PowerEdge R260. Refer to Agile for the latest SDL.

Table 12. Supported Drives

Form Factor	Type	Speed	Rotational Speed	Capacities
2.5 inches	SAS	12 Gbps	10 K	600 GB, 1.2 TB, 2.4 TB
	SAS	24 Gbps	SSD	800 GB, 1.6 TB, 1.92 TB, 3.84 TB, 7.68 TB
	SATA	6 Gbps	SSD	480 GB, 960 GB, 1.92 TB, 3.84 TB
3.5 inches	SAS	12 Gbps	7.2 K	2 TB, 4 TB, 8 TB, 12 TB, 16 TB

Table 12. Supported Drives (continued)

Form Factor	Type	Speed	Rotational Speed	Capacities
	SATA	6 Gbps	7.2 K	2 TB, 4 TB, 8 TB, 12 TB, 16 TB

Internal storage configuration

PowerEdge R260 supports the following internal storage configurations:

- 6 x 2.5-inch SAS/SATA RAID
- 2 x 3.5-inch SAS/SATA RAID
- 4 x 2.5-inch SATA SWRAID

 **NOTE:** The PowerEdge R260 system does not support rear storage.

External Storage

The PowerEdge R260 supports the external storage device types that are listed in the table below.

Table 13. Supported External Storage Devices

Device Type	Description
External Tape	Supports connection to external USB tape products
NAS/IDM appliance software	Supports NAS software stack
JBOD	Supports connection to 12 Gb MD-series JBODs

Networking

Topics:

- [Overview](#)
- [Supported network cards](#)

Overview

PowerEdge offers a wide variety of options to get information moving to and from our servers. Industry best technologies are chosen, and systems management features are added by our partners to firmware to tie in with iDRAC. These adapters are rigorously validated for worry-free, fully supported use in Dell servers.

Supported network cards

Table 14. Supported network cards

Vendor	Port type	Port speed	Port count
Broadcom	F1	1 GbE	4
Intel	BT	10 GbE	2
Intel	BT	10 GbE	4
Broadcom	BT	10 GbE	3
Broadcom	BT	10 GbE	4
Intel	F1	1 GbE	4

PCIe subsystem

Topics:

- [PCIe risers](#)

PCIe risers

The PowerEdge R260 system supports a Gen4 butterfly riser on the system.

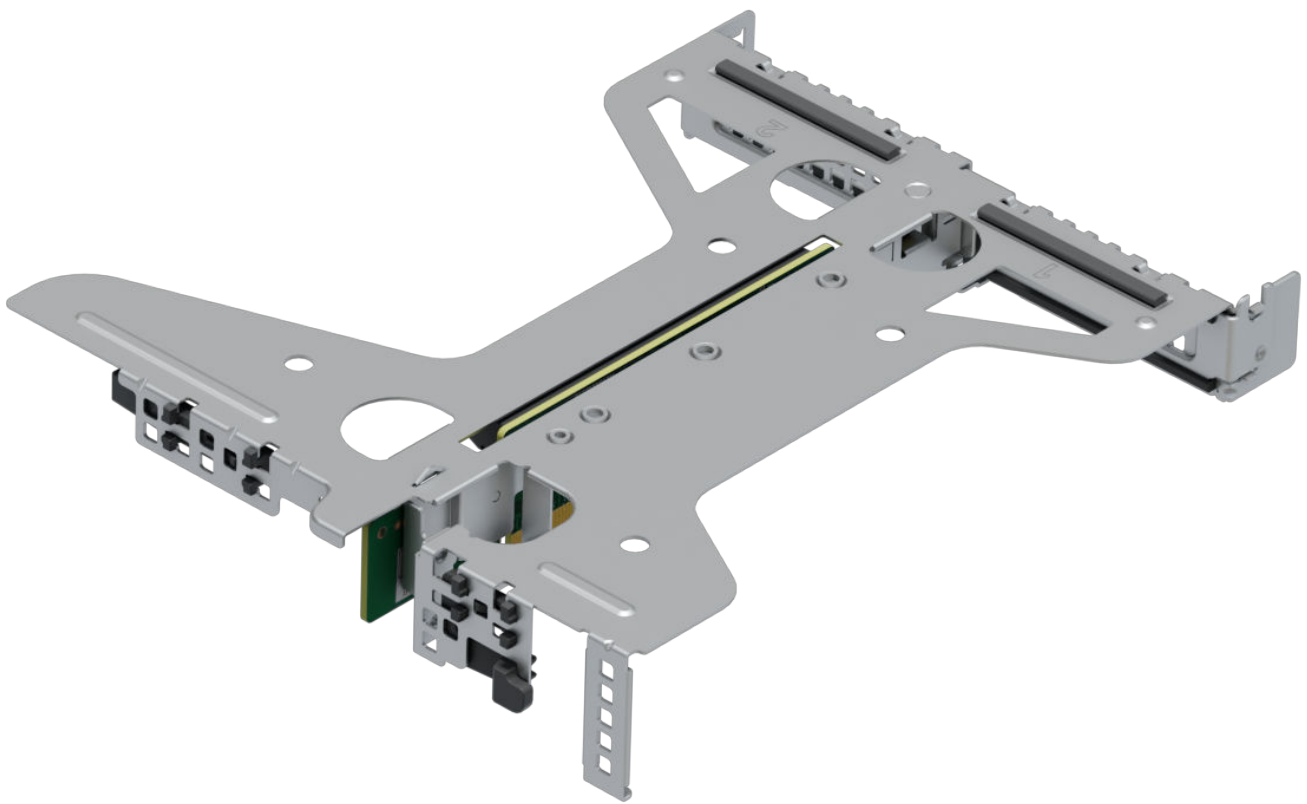

Figure 11. Butterfly Riser

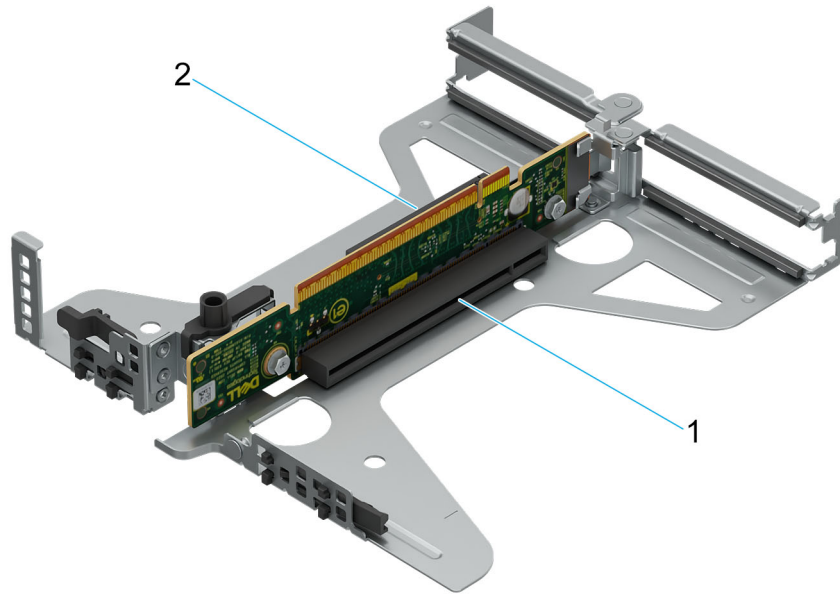

Figure 12. Butterfly Riser

- 1. PCIe Slot 2
- 2. PCIe Slot 1

Table 15. PCIe riser configurations

Configuration No.	Riser Configuration	No. of Processors	PERC type supported on riser	Rear Storage Possible
RC0	No Riser	1	N/A	No
RC1	1x Riser (Gen4)	1	aPERC	No

Power, thermal, and acoustics

PowerEdge servers have an extensive collection of sensors that automatically track thermal activity, which helps to regulate temperature by reducing server noise and power consumption. The table below lists the tools and technologies Dell offers to lower power consumption and increase energy efficiency.

Topics:

- [Power](#)
- [Thermal](#)
- [Acoustics](#)

Power

Table 16. Power tools and technologies

Feature	Description
Power Supply Units(PSU) portfolio	Dell's PSU portfolio includes intelligent features such as dynamically optimizing efficiency while maintaining availability and redundancy. Find additional information in the Power supply units section.
Tools for right sizing	Enterprise Infrastructure Planning Tool (EIPT) is a tool that can help you determine the most efficient configuration possible. With Dell's EIPT, you can calculate the power consumption of your hardware, power infrastructure, and storage at a given workload. Learn more at Dell EIPT .
Industry Compliance	Dell's servers are compliant with all relevant industry certifications and guide lines, including 80 PLUS, Climate Savers and ENERGY STAR.
Power monitoring accuracy	PSU power monitoring improvements include: <ul style="list-style-type: none"> • Dell's power monitoring accuracy is currently 1%, whereas the industry standard is 5% • More accurate reporting of power • Better performance under a power cap
Power capping	Use Dell's systems management to set the power cap limit for your systems to limit the output of a PSU and reduce system power consumption. Dell is the first hardware vendor to leverage Intel Node Manager for circuit-breaker fast capping.
Systems Management	iDRAC Enterprise and Datacenter provides server-level management that monitors, reports and controls power consumption at the processor, memory and system level. Dell OpenManage Power Center delivers group power management at the rack, row, and data center level for servers, power distribution units, and uninterruptible power supplies.
Active power management	Intel Node Manager is an embedded technology that provides individual server-level power reporting and power limiting functionality. Dell offers a complete power management solution comprised of Intel Node Manager accessed through Dell iDRAC9 Datacenter and OpenManage Power Center that allows policy-based management of power and thermal at the individual server, rack, and data center level. Hot spare reduces power consumption of redundant power supplies. Thermal control off a speed optimizes the thermal settings for your environment to reduce fan consumption and lower system power consumption. Idle power enables Dell servers to run as efficiently when idle as when at full workload.
Rack infrastructure	Dell offers some of the industry's highest-efficiency power infrastructure solutions, including:

Table 16. Power tools and technologies (continued)

Feature	Description
	<ul style="list-style-type: none"> • Power distribution units (PDUs) • Uninterruptible power supplies (UPSs) • Energy Smart containment rack enclosures Find additional information at: Power and Cooling .

Power Supply Units

Energy Smart power supplies have intelligent features, such as the ability to dynamically optimize efficiency while maintaining availability and redundancy. Also featured are enhanced power-consumption reduction technologies, such as high-efficiency power conversion and advanced thermal-management techniques, and embedded power-management features, including high-accuracy power monitoring. The table below shows the power supply unit options that are available for the PowerEdge R260.

Table 17. Power Supply Unit Options

Wattage	Frequency	Voltage/Current	Class	Heat dissipation
450 W	50/60 Hz	100-240 Vac/6.5 - 3.5 A	Platinum	1730 BTU/hr
700 W	50/60 Hz	200-240 Vac/4.1 A	Titanium	2625 BTU/hr
	N/A	240 Vdc/3.4 A	N/A	

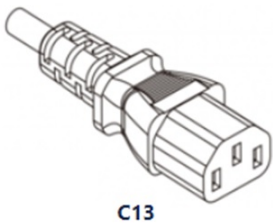

Figure 13. PSU power cord

Table 18. PSU power cords

Form factor	Output	Power cord
Cable PSU 106 mm	450 W	C13 /C14 (inlet)
Non cabled PSU 60 mm	700 W	

Thermal

PowerEdge servers have an extensive collection of sensors that automatically track thermal activity, which helps regulate temperature thereby reducing server noise and power consumption.

Thermal design

Thermal management of the platform helps deliver high performance with the right amount of cooling to components, while maintaining the lowest fan speeds possible. This is done across a wide range of ambient temperatures from 10°C to 35°C (50°F to 95°F) and to extended ambient temperature ranges.

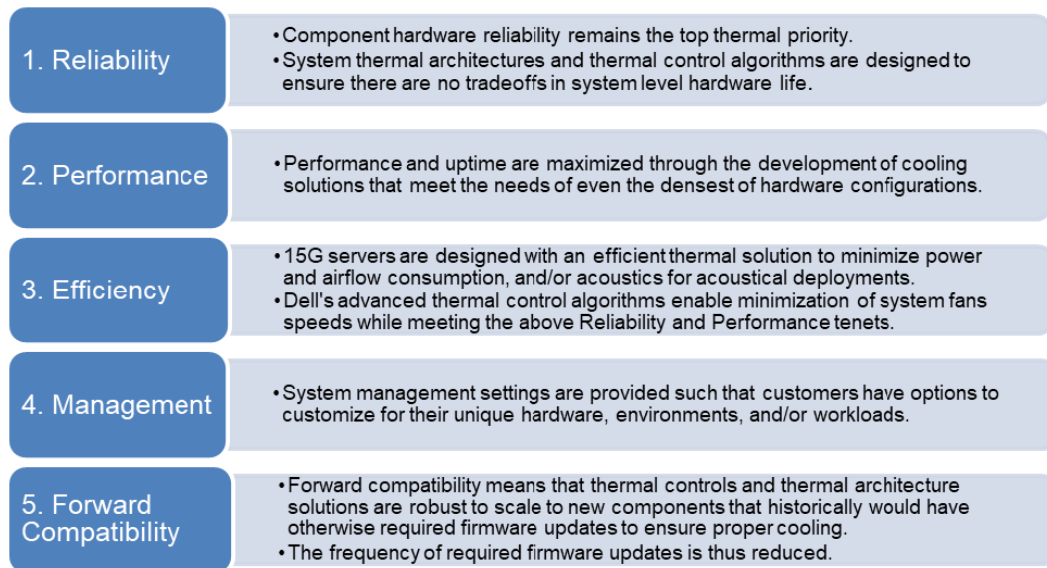

Figure 14. Thermal design characteristics

The thermal design of the PowerEdge R260 reflects the following:

- Optimized thermal design: The system layout is architected for optimum thermal design.
- System component placement and layout are designed to provide maximum airflow coverage to critical components with minimum expense of fan power.
- Comprehensive thermal management: The thermal control system regulates the fan speed based on several different responses from all system-component temperature sensors, as well as inventory for system configurations. Temperature monitoring includes components such as processors, DIMMs, chipset, the inlet air ambient, hard disk drives, and OCP.
- Open and closed loop thermal fan speed control: Open loop thermal control uses system configuration to determine fan speed based on inlet air ambient temperature. Closed loop thermal control method uses feedback temperatures to dynamically determine proper fan speeds.
- User-configurable settings: With the understanding and realization that every customer has unique set of circumstances or expectations from the system, in this generation of servers, we have introduced limited user- configurable settings residing in the iDRAC BIOS setup screen. For more information, see the Dell PowerEdge R260 Installation and Service Manual at [PowerEdge Manuals](#) and “Advanced Thermal Control: Optimizing across Environments and Power Goals” on Dell.com.
- Cooling redundancy: The PowerEdge R260 allows N+1 fan redundancy, allowing continuous operation with one fan failure in the system.
- Environmental Specifications: The optimized thermal management makes the PowerEdge R260 reliable under a wide range of operating environments.

Acoustics

Acoustical performance

Dell PowerEdge R260 is a rackmount server appropriate for attended data center environment. In fact, with typical loading condition in 23°C ± 2 °C ambient temperature, R260 is suitable for the office environment.

Table 19. Hardware and software configurations for lower acoustical output

Configuration	Economy	Volume	Volume with BOSS	Feature Rich
Processor	Xeon E-2400/Xeon 6300 series, 70 W	Xeon E-2400/Xeon 6300 series, 70 W	Xeon E-2400/Xeon 6300 series, 70 W	Xeon E-2400/Xeon 6300 series,95 W
Processor Quantity	1	1	1	1
Memory	16GB UDIMM	32GB UDIMM	32GB UDIMM	32GB UDIMM
Memory Quantity	1	2	2	4
Storage	3.5" SATA 2-TB	3.5" SATA 2-TB	3.5" SATA 2-TB	2.5" 600G SAS HDD
Storage Quantity	2	2	2	6
Backplane	2x 3.5" Cabled	2x 3.5" Cabled	2x 3.5" Cabled	6x 2.5" Hot Plug
BOSS	N/A	N/A	Yes	N/A
Power Supply Unit	450W (106mm)	450W (106mm)	450W (106mm)	450W (106mm)
Quantity	1	1	1	1
PCI 1	None (Chipset SATA)	PERC H355i	PERC H355i	PERC H355i, 2x 1GbE Broadcom
Bezel	N/A	Yes	Yes	N/A
Other	N/A	N/A	N/A	N/A

Table 20. Acoustical performance of R260 acoustical configurations

Configuration	Economy	Volume	Volume with BOSS	Feature Rich	
Acoustical Performance: Idle/ Operating @ 25 °C Ambient					
L _{WA,m} (B)	Idle	4.4	4.4	4.4	5.0
	Operating	4.4	4.4	4.4	5.7
K _v (B)	Idle	0.4	0.4	0.4	0.4
	Operating	0.4	0.4	0.4	0.4
L _{pA,m} (dB)	Idle	30	30	30	36
	Operating	30	30	30	44
Prominent tones	No prominent tones in Idle and Operating				
Acoustical Performance: Idle @ 28 °C Ambient					
L _{WA,m} (B)	4.4	4.4	4.4	5.0	
K _v (B)	0.4	0.4	0.4	0.4	
L _{pA,m} (dB)	30	30	30	36	
Acoustical Performance: Max. Loading @ 35 °C Ambient					
L _{WA,m} (B)	6.4	6.4	6.4	7.5	

Table 20. Acoustical performance of R260 acoustical configurations (continued)

Configuration	Economy	Volume	Volume with BOSS	Feature Rich
K_v (B)	0.4	0.4	0.4	0.4
$L_{pA,m}$ (dB)	49	49	49	62

LwA,m: The declared mean A-weighted sound power level (LwA) is calculated per section 5.2 of ISO 9296 (2017) with data collected using the methods that are described in ISO 7779 (2010). Data presented here may not be fully compliant with ISO 7779.

LpA,m: The declared mean A-weighted emission sound pressure level is at the bystander position per section 5.3 of ISO 9296 (2017) and measured using methods that are described in ISO 7779 (2010). The system is placed in a 24U rack enclosure, 25 cm above a reflective floor. Data presented here may not be fully compliant with ISO 7779.

Prominent tones: Criteria of D.6 and D.11 of ECMA-74 (17th ed., Dec. 2019) are followed to determine if discrete tones are prominent and to report them, if so.

Idle mode: The steady-state condition in which the server is energized but not operating any intended function.

Operating mode: The maximum of the steady state acoustical output at 50% of CPU TDP or active HDDs per C.9.3.2 in ECMA-74 (17th ed., Dec. 2019)

Rack, rails, and cable management

Topics:

- [Rack Rails](#)

Rack Rails

The ReadyRails™ static rail system for the Dell PowerEdge R260 provides tool-less support for racks with square or unthreaded round mounting holes including all generations of Dell racks. The rails also offer tooled-mounting support for four-post threaded and two-post (Telco) racks for added versatility.

Rails

The static rails for the R260 support tool-less mounting in 19-inch wide, EIA-310-E compliant square hole and unthreaded round hole racks through the ReadyRails mounting interface. The rails also support a generic mounting interface for tooled mounting in threaded hole and two-post (Telco) racks. Note that screws are not included in the kit due to the fact that threaded racks are offered with a variety of thread designations. Users must therefore provide their own screws when mounting the rails in threaded or two-post racks.

The adjustment range of the rails is a function of the type of rack in which they are being mounted. The Min/Max values listed below represent the allowable distance between the front and rear mounting flanges in the rack. Rail depth represents the minimum depth of the rail as measured from the rack front mounting flanges when the rail rear bracket is positioned all the way forward.

Table 21. Supported rack types

Product	Rail ID	Mounting Interface	Rail Type	Rack Types Supported				
				4-Post			2-Post	
				Square	Round	Thread	Flush	Center
R260	A4	ReadyRails /Generic	Static	√	√	√	√	√

Table 22. Rail adjustment range for supported racks

Adjustment Range											
Product	Rail ID	Mounting Interface	Rail Type	Rail Adjustment Range (mm)						Rail Depth (mm)	
R260	A4	ReadyRails /Generic	Static	Square		Round		Threaded		Without CMA	With CMA
				Min	Max	Min	Max	Min	Max		
				608	879	594	872	610	898	622	N/A

Cable Management Arm

The static rails for the R260 support a wide variety of racks and mounting configurations, but do not support the ability to extend the system out of the rack for service. Thus, they do not provide support for a cable management arm (CMA).

Rack View

The PowerEdge R260 rails are a “stab-in” design, meaning that the inner (chassis) rail members must first be attached to the sides of the system and then inserted into the outer (cabinet) members installed in the rack.



Figure 15. R260 mounted in the A4 Static Rails in 2-post Center Mount configuration



Figure 16. A4 static rails installed to 4-Post rack

Operating Systems and Virtualization

Topics:

- [Supported Operating Systems](#)

Supported Operating Systems

The PowerEdge system supports the following operating systems:

- Canonical® Ubuntu® Server LTS
- Microsoft® Windows Server® with Hyper-V
- Red Hat® Enterprise Linux
- SUSE® Linux Enterprise server
- VMware® ESXi®

Links to specific OS versions and editions, certification matrices, Hardware Compatibility Lists (HCL) portal, and Hypervisor support are available at [Dell Enterprise Operating Systems](#).

Dell Systems Management

Dell delivers management solutions that help IT administrators effectively deploy, update, monitor, and manage IT assets. Dell solutions and tools enable you to quickly respond to problems by helping them to manage Dell servers efficiently; in physical, virtual, local, and remote environments; all without the need to install an agent in the operating system.

The OpenManage portfolio includes:

- Innovative embedded management tools - integrated Dell Remote Access Controller (iDRAC)
- Consoles - OpenManage Enterprise
- Extensible with plug-ins - OpenManage Power Manager
- Update tools - Repository Manager

Dell has developed comprehensive systems management solutions that are based on open standards and has integrated with management consoles from partners such as Microsoft and VMware, allowing advanced management of Dell servers. Dell management capabilities extend to offerings from the industry's top systems management vendors and frameworks such as Ansible, Splunk, and ServiceNow. OpenManage tools automate the full span of server life cycle management activities along with powerful RESTful APIs to script or integrate with your choice of frameworks.

For more information about the entire OpenManage portfolio, see:

- The latest [Dell Systems Management Overview Guide](#).

Topics:

- [Integrated Dell Remote Access Controller \(iDRAC\)](#)
- [Systems Management software support matrix](#)

Integrated Dell Remote Access Controller (iDRAC)

iDRAC9 delivers advanced, agent-free, local and remote server administration. Embedded in every PowerEdge server, iDRAC9 provides a secure means to automate a multitude of common management tasks. Because iDRAC is embedded within every PowerEdge server, there is no additional software to install; just plug in power and network cables, and iDRAC is ready to go. Even before installing an operating system (operating system) or hypervisor, IT administrators have a complete set of server management features at their fingertips.

With iDRAC9 in-place across the Dell PowerEdge portfolio, the same IT administration techniques and tools can be applied throughout. This consistent management platform allows easy scaling of PowerEdge servers as an organization's infrastructure grows. Customers can use the iDRAC RESTful API for the latest in scalable administration methods of PowerEdge servers. With this API, iDRAC enables support for the Redfish standard and enhances it with Dell extensions to optimize at-scale management of PowerEdge servers. By having iDRAC at the core, the entire OpenManage portfolio of Systems Management tools allows every customer to tailor an effective, affordable solution for any size environment.

Zero Touch Provisioning (ZTP) is embedded in iDRAC. ZTP - Zero Touch Provisioning is Intelligent Automation Dell's agent-free management puts IT administrators in control. Once a PowerEdge server is connected to power and networking, that system can be monitored and fully managed, whether you're standing in front of the server or remotely over a network. In fact, with no need for software agents, an IT administrator can: · Monitor · Manage · Update · Troubleshoot and remediate Dell servers. With features like zero-touch deployment and provisioning, iDRAC Group Manager, and System Lockdown, iDRAC9 is purpose-built to make server administration quick and easy. For those customers whose existing management platform utilizes in-band management, Dell does provide iDRAC Service Module, a lightweight service that can interact with both iDRAC9 and the host operating system to support legacy management platforms.

When ordered with DHCP enabled from the factory, PowerEdge servers can be automatically configured when they are initially powered up and connected to your network. This process uses profile-based configurations that ensure each server is configured per your specifications. This feature requires an iDRAC Enterprise license.

iDRAC9 offers following license tiers:

Table 23. iDRAC9 license tiers

License	Description
iDRAC9 Basic	<ul style="list-style-type: none"> Available only on 100-500 series rack/tower Basic instrumentation with iDRAC web UI For cost conscious customers that see limited value in management
iDRAC9 Express	<ul style="list-style-type: none"> Default on 600+ series rack/tower, modular, and XR series Includes all features of Basic Expanded remote management and server life-cycle features
iDRAC9 Enterprise	<ul style="list-style-type: none"> Available as an upsell on all servers Includes all features of Basic and Express. Includes key features such as virtual console, AD/LDAP support, and more Remote presence features with advanced, Enterprise-class, management capabilities
iDRAC9 Datacenter	<ul style="list-style-type: none"> Available as an upsell on all servers Includes all features of Basic, Express, and Enterprise. Includes key features such as telemetry streaming, Thermal Manage, automated certificate management, and more Extended remote insight into server details, focused on high end server options, granular power, and thermal management

For a full list of iDRAC features by license tier, see [Integrated Dell Remote Access Controller 9 User's Guide](#) at [Dell.com](#).

For more details on iDRAC9 including white papers and videos, see:

- [Support for Integrated Dell Remote Access Controller 9 \(iDRAC9\)](#) on the [Knowledge Base](#) page at [Dell.com](#)

Systems Management software support matrix

Table 24. Systems Management software support matrix

Categories	Features	PE mainstream
Embedded Management and In-band Services	iDRAC9 (Express, Enterprise, and Datacenter licenses)	Supported
	OpenManage Mobile	Supported
	OM Server Administrator (OMSA)	Supported
	iDRAC Service Module (iSM)	Supported
	Driver Pack	Supported
Change Management	Update Tools (Repository Manager, DSU, Catalogs)	Supported
	Server Update Utility	Supported
	Lifecycle Controller Driver Pack	Supported
	Bootable ISO	Supported
Console and Plug-ins	OpenManage Enterprise	Supported
	Power Manager Plug-in	Supported
	Update Manager Plug-in	Supported
	SupportAssist Plug-in	Supported
	CloudIQ	Supported
Integrations and connections	OM Integration with VMware Vcenter/vROps	Supported
	OM Integration with Microsoft System Center (OMIMSC)	Supported
	Integrations with Microsoft System Center and Windows Admin Center (WAC)	Supported

Table 24. Systems Management software support matrix (continued)

Categories	Features	PE mainstream
	ServiceNow	Supported
	Ansible	Supported
	Third-party Connectors (Nagios, Tivoli, Microfocus)	Supported
Security	Secure Enterprise Key Management	Supported
	Secure Component Verification	Supported
Standard operating system	Red Hat Enterprise Linux, SUSE, Windows Server 2019 or 2022, Ubuntu, CentOS	Supported (Tier-1)

Appendix D: Service and support

Topics:

- [Why attach service contracts](#)
- [ProSupport Infrastructure Suite](#)
- [Specialty Support Services](#)
- [ProDeploy Infrastructure Suite](#)
- [Supplemental Deployment Services](#)
- [Unique Deployment Scenarios](#)
- [DAY 2 – Automation Services with Ansible](#)
- [Dell Technologies Consulting Services](#)

Why attach service contracts

Dell PowerEdge servers include a standard hardware warranty that highlights our commitment to product quality by guaranteeing repair or replacement of defective components. While industry-leading, our warranties are limited to 1 or 3 years, depending on model, and do not cover software assistance. Call records show that customers are most often seeking Dell technical support for software related issues like configuration guidance, troubleshooting, upgrade assistance or performance tuning. Encourage customers to purchase ProSupport service contracts to supplement warranty coverage and ensure optimal support for both hardware and software. ProSupport provides a complete hardware guarantee beyond the original warranty period.

ProSupport Infrastructure Suite

ProSupport Infrastructure Suite is a set of support services that enable customers to build the solution that is right for their organization. It is an industry-leading, enterprise-class support that aligns with the criticality of your systems, the complexity of your environment, and the allocation of your IT resources.

Figure 17. ProSupport Enterprise Suite

	Basic Hardware Support	ProSupport	BEST ProSupport Plus
Customer Advocacy via assigned Services Account Manager ①			
Benefit from personalized services assistance that aligns with your business goals.			✓
Stay ahead of challenges with actionable insights gained through comprehensive service intelligence.			✓
Experience fast critical issue resolution through coordinated team response and executive escalation paths.			✓
Ensure coverage continuity by planning effectively for technology lifecycle transitions.			✓
Proactive Monitoring & Actionable Insights via Dell's connectivity solutions and tools			
Quickly visualize performance through a current system health score		✓	✓
Cybersecurity monitoring and mitigation recommendations provide another layer of protection		✓	✓
Predictive performance and capacity analysis address bottlenecks		✓	✓
Prevent or plan for downtime with predictive hardware anomaly detection		✓	✓
Energy consumption and carbon footprint forecasting support sustainability and stewardship initiatives		✓	✓
Get ahead of problems with proactive issue detection with automated case creation	✓	✓	✓
Streamline internal IT efforts with efficient service request and escalation management tools	✓	✓	✓
Minimize disruptions by self-dispatching eligible parts	✓	✓	✓
Support Essentials			
Keep systems code current and performing at peak through Proactive System Maintenance			✓
Count on Mission Critical Support during Sev 1 incidents and natural disasters ①			✓
Enjoy priority access to senior technical support engineers			✓
Bringing your own software? We provide limited 3rd party software support ①			✓
Choose onsite parts delivery and labor response that meets your needs	Next Business Day	NBD or 4-hour	4-hour
Select product coverage that best augments your internal resources	Hardware	Hardware & Software	Hardware & Software
Have an issue? We are here for you by phone, chat and online	Local business hours	24/7/365	24/7/365

ProSupport Plus for Infrastructure

ProSupport Plus for Infrastructure is the ultimate solution for customers seeking preventative maintenance and optimal performance on their business-critical assets. The service caters to customers who require proactive, predictive, and personalized support for systems that manage critical business applications and workloads. When customers purchase PowerEdge server, we recommend ProSupport Plus, our proactive and preventative support service for business-critical systems. ProSupport Plus provides all the benefits of ProSupport, including the following “Top five reasons to buy ProSupport Plus (PSP)”

- 1. Priority access to specialized support experts:** Immediate advanced troubleshooting from an engineer that understands Dell infrastructure solutions.
- 2. Mission Critical Support:** When critical (Severity 1) support issues happen, the customer is assured that we do all that we can to get them back up and running as quickly as possible.
- 3. Service Account Manager:** A customer’s #1 support advocate, ensuring they get the best possible proactive and predictive support experience.
- 4. Systems maintenance:** On a semiannual basis, we will keep a customer’s ProSupport Plus system(s) up to date by installing the latest firmware, BIOS, and driver updates to improve performance and availability.
- 5. Third-party software support:** Dell is a customer’s single point of accountability for any eligible third-party software that is installed on their ProSupport Plus system, whether they purchased the software from us or not.

ProSupport for Infrastructure

Comprehensive 24x7 support for hardware and software – best for production, but not critical, workloads and applications. The ProSupport service offers highly trained experts around the clock and around the globe to address IT needs. We help minimize disruptions and maximize availability of PowerEdge server workloads with:

- 24x7 support through phone, chat and online
- A central point of accountability for all hardware and software issues
- Hypervisor, operating system, and application support
- Dell security advisories
- Onsite response service levels 4 hour or Next Business Day options

- Proactive issue detection with automated case creation
- Predictive hardware anomaly detection
- Incident Manager assigned for Severity 1 cases
- Collaborative third-party support
- Access to AIOps Platforms - (MyService360, TechDirect, and CloudIQ)
- Consistent experience regardless of where customers are located or what language that they speak.

Basic Hardware Support

Provides reactive hardware support during normal business hours, excluding local national holidays. No software support or software-related guidance. For improved levels of support, choose ProSupport or ProSupport Plus.

Specialty Support Services

Optional specialty support services complement the ProSupport Infrastructure Suite to provide additional proficiencies that are critical for modern data center operations.

Hardware coverage add-ons to ProSupport

- **Keep Your Hard Drive (KYHD), Keep Your Component (KYC), or Keep Your GPU (KYGPU):**

Normally if a device fails under warranty, Dell replaces it using a one-for-one exchange process. KYHD/KYCC/KYGPU gives you the option to retain your device. It provides full control of sensitive data and minimizes security risk by letting you retain possession of failed drives, components, or GPU when receiving replacement parts without incurring additional cost.

- **Onsite Diagnosis Service:**

Ideal for sites with non-technical staff. Dell field technician performs initial troubleshooting diagnosis onsite and transfers to Dell remote engineers to resolve the issue.

- **ProSupport Add-on for HPC:**

Sold as an add-on to a ProSupport service contract, the ProSupport Add-on for HPC provides solution-aware support to cover the additional requirements that are required to maintain an HPC environment such as:

- Access to senior HPC experts
- Advanced HPC cluster assistance: Performance, interoperability, and configuration
- Enhanced HPC solution level end-to-end support
- Remote pre-support engagement with HPC Specialists during ProDeploy implementation

- **ProSupport Add-on for Telco (Respond & Restore):**

An add-on service designed for the top 31 TELCO customers globally, Respond & Restore provides direct access to Dell solution experts who specialize in TELCO carrier-grade support. This add-on also provides a hardware uptime guarantee, meaning if a system fails, Dell has it installed and operational within 4 hours for Severity 1 issues. Dell incurs penalties and fees if SLAs are not met.

Personalized Support and Supplemental Site-wide Expertise

- **Technical Account Manager:**

Designated technology lead who monitors and manages the performance and configuration of specific technology sets.

- **Designated Remote Support:**

Personalized support expert who manages all troubleshooting and resolution of IT assets.

- **Multivendor Support Service:**

Support your third-party devices as one service plan for servers, storage, and networking (includes coverage for: Broadcom, Cisco, Fujitsu, HPE, Hitachi, Huawei, IBM, Lenovo, NetApp, Oracle, Quanta, SuperMicro and others).

Services for large enterprises

- **ProSupport One for Data Center:**

ProSupport One for Data Center offers flexible site-wide support for large and distributed data centers with more than 1,000 assets (combined total of server, storage, networking, so forth). This offering is built on standard ProSupport features that leverage our global scale and are tailored to specific customer needs. While not for everyone, this service option offers a truly unique solution for our largest customers with the most complex environments.

- Team of assigned Services Account Managers with remote or onsite options
- Assigned technical and field engineers who are trained on the customer's environment and configurations.
- On-demand reporting and recommendations that are enabled by ProSupport AIOps tools (MyService360, TechDirect, and CloudIQ)
- Flexible onsite support and parts options that fit their operational model
- A tailored support plan and training for their operations staff

- **ProSupport One for CSPs (Cloud Serviced Providers)**

ProSupport One for CSPs is a unique offer that is designed for a limited set of Dell accounts purchasing Gen AI computing solutions greater than 1,000 servers and \$250M in sales. PS1 for CSPs improves the entire services experience combining support, deployment (rack integration), residency services, a designated support engineer and the LOIS parts locker as one holistic bundle. Special pricing has been determined to compete effectively against competitors and provide the best customer experience. PS1 for CSPs can only be sold with XE Servers and all networking platforms (Dell and NVIDIA). All other products would be eligible for the standard PS1DC not this special bundle offer. More details on PS1 for CSPs [here](#).

- **Logistics Online Inventory Solution (LOIS)**

Ideal for large organizations that have their own staff to support their data center. Dell offers a service that is called Logistics Online Inventory Solution which is an onsite parts locker that provides self-maintainers with a local inventory of common replacement components. Having access to these parts lockers allows the self-maintainer to replace a failed component immediately without delay. Each replacement part would automatically initiate a replenishment of the parts inventory that is shipped the next day or delivered onsite by Dell during a regular scheduled visit (called Scheduled Onsite Service). As part of the LOIS system, customers can integrate their systems directly to Dell TechDirect using APIs to help streamline the support management process.

End-of-Life Services

- **Post Standard Support (PSS)**

Extend service life beyond the initial seven years of ProSupport, adding up to five more additional years of hardware coverage.

- **Data Sanitization & Data Destruction**

Renders data unrecoverable on repurposed or retired products, ensuring security of sensitive data and enabling compliance and provides NIST-compliant certification.

- **Asset Recovery Services**

Recycle, resale, and disposal of hardware. Helps you securely and responsibly retire IT assets that are no longer needed while protecting both your business and the planet.

ProDeploy Infrastructure Suite

ProDeploy Infrastructure Suite provides various deployment offerings that satisfy a customer's unique needs. It is made up of various sub-offers: Factory Configuration Services, Rack Integration, Basic Deployment, ProDeploy, ProDeploy Plus, and optionally ProDeploy FLEX which allows for some customization of the features listed.

ProDeploy Infrastructure Suite

Versatile choices for accelerated deployments

NOTE: All XE Series servers require mandatory deployment

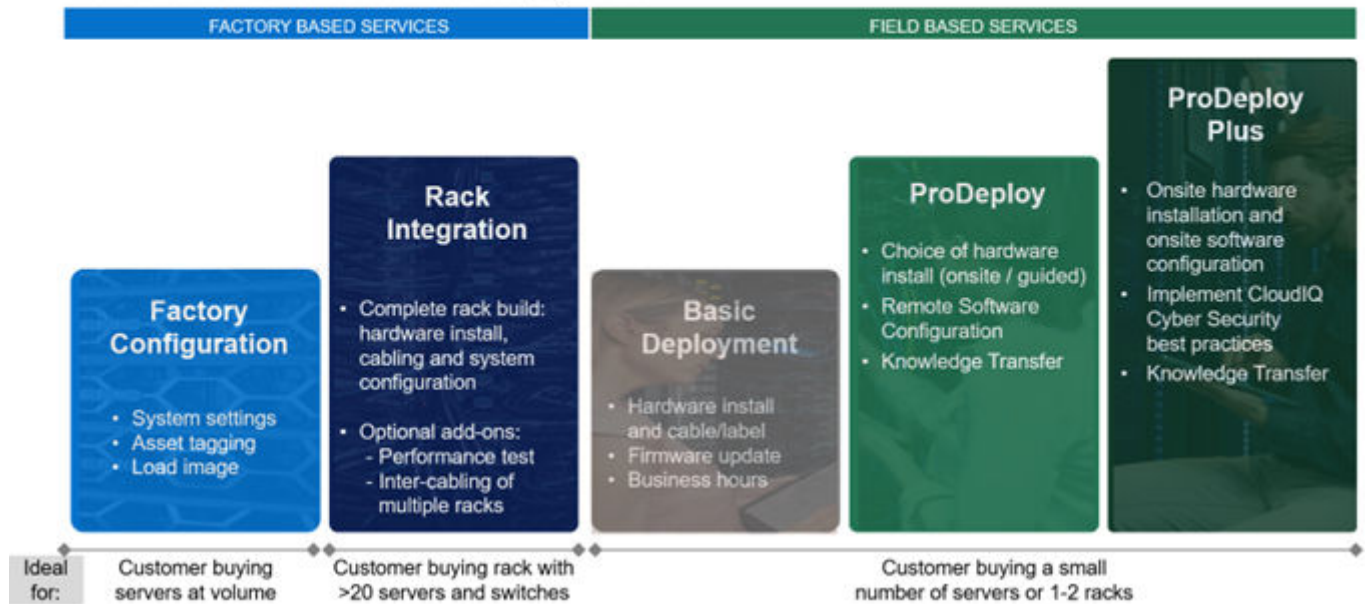

Figure 18. ProDeploy Infrastructure Suite

Factory-based Services

Pre-configured systems or complete racks, customized prior to shipping to the customer's site.

Rack Integration or ProDeploy FLEX Rack Integration

Ideal for customers buying servers in volume and seeking pre-configuration prior to shipping such as: custom image, system settings, and asset tagging so it arrives ready to use out of the box. Furthermore, servers are packaged and bundled to meet specific shipping and distribution requirements for each customer location to facilitate the rollout process. Once the server is onsite, Dell can install and configure the server to the environment using any of the field-based deployment services outlined in the next section.

- STANDARD SKUs for Rack Integration is available in then USA only and requires:
 - 20 or more devices (XE, R and C series servers, VxRail and all Dell or non-Dell switches).
 - Shipping to contiguous USA.
- USE CUSTOM QUOTE for Rack Integration scenarios that require:
 - Any Direct Liquid Cooling (DLC) implementation
 - Shipping to multiple locations or shipment to any country outside USA or shipping outside contiguous USA
 - Air-cooled racks containing less than 20 servers
 - Any rack that includes Storage

Factory Configuration

Ideal for customers buying servers in volume and seeking pre-configuration prior to shipping such as: custom image, system settings, and asset tagging so it arrives ready to use out of the box. Furthermore, servers are packaged and bundled to meet specific shipping and distribution requirements for each customer location to facilitate the rollout process. Once the server is onsite, Dell can install and configure the server to the environment using any of the field-based deployment services outlined in the next section.

ProDeploy Flex | Modular deployment (built in factory, onsite or remote)

Pre -deployment	Single point of contact for project management	●
	Expanded end-to-end project management	Selectable
	Site readiness review and implementation planning	●
Deployment	Deployment service hours	24/7
	Hardware installation options ¹	Onsite, factory ^{2,5} or remote ³
	System software installation and configuration options ¹	Onsite, factory ^{2,5} or remote ³
	Multivendor networking deployment ⁴	Onsite, factory ^{2,5} or remote ³
	Onsite Deployment in remote locations	Selectable
	Onsite Deployment in challenging environments	Selectable
	Onsite Deployment with special site-based protocols or requirements	Selectable
	Install connectivity software based on Secure Connect Gateway technology	●
	Dell NativeEdge Orchestrator deployment	Selectable
	Configure 3 rd party software applications and workloads ⁴	Selectable
Post -deployment	Deployment verification, documentation, and knowledge transfer	●
	Configuration data transfer to Dell support	●
Online collaboration	Online collaborative environment - Planning, managing and tracking delivery process	●

¹ Hardware and Software delivery methods can be independently chosen; selecting Rack integration for software requires hardware Rack integration to also be selected.

² Factory Rack Integration for server and VxRail; includes associated Dell network switches; final onsite rack installation available.

³ Remote hardware option includes project specific instructions, documentation and live expert guidance for hardware installation.

⁴ Select 3rd party multivendor networking and software applications.

⁵ Pair with Field Onsite Hardware service for final installation.

Figure 19. ProDeploy Flex modular services

Field-based services

Put PowerEdge servers to work faster with Dell field-based deployment services. Whether we are deploying one server to one thousand – we have you covered. Dell provides versatile delivery options to fit every budget and operating model.

- **ProDeploy Plus:** Elevate Infrastructure deployments with our most complete service from planning through onsite hardware installation and software configuration including the implementation of cybersecurity best practices. ProDeploy Plus provides the skill and scale that is needed to successfully execute demanding deployments in today's complex IT environments. The deployment starts with a site readiness review and implementation plan. Certified deployment experts perform the software configuration to include setup of leading operating systems and hypervisors. Dell will also configure PowerEdge software tools to include iDRAC and OpenManage system utilities as well as support AIOps platforms: MyService360, TechDirect, and CloudIQ. Unique to ProDeploy Plus, the cybersecurity implementation helps customers understand potential security risks and make recommendations for reducing product attack surfaces. The system is tested, validated prior to completion. The customer will also receive full project documentation and knowledge transfer to complete the process.
- **ProDeploy:** ProDeploy provides remote software configuration and choice of hardware installation (onsite or guided). ProDeploy is great for customers who are price sensitive or willing to participate in some portion of the deployment to include providing remote access to their network. The ProDeploy remote software includes everything mentioned in ProDeploy Plus except it does not include the added value, cybersecurity implementation, and implementation best practices.
- **Basic Deployment:** Basic Deployment delivers worry-free professional installation by experienced technicians. This service is often sold to Competency Enabled Partners who will have Dell do the hardware installation while they complete the software configuration. Furthermore, Basic Deployment tends to be purchased by large enterprises who have smart technical staff. These companies just need Dell to install the hardware, and they will perform the software configuration. The last use case for Basic Deployment is when paired with Factory Configuration services. The servers are preconfigured in the factory, and the basic deployment service will install the system into the rack to finalize the deployment.

ProDeploy Infrastructure Suite | Field services

		Basic Deployment	ProDeploy	ProDeploy Plus
Pre-deployment	Single point of contact for project management	-	●	In region
	Site readiness review and implementation planning	-	●	●
Deployment	Deployment service hours	Business hours	24/7	24/7
	Hardware installation options	Onsite	Onsite or guided ¹	Onsite
	System software installation and configuration options	-	Remote	Onsite
	Install connectivity software based on Secure Connect Gateway technology ²	-	●	●
	Implement CyberSecurity best practices and policies in APEX AIOps Infrastructure Observability	-	-	●
Post-deployment	Deployment verification, documentation and knowledge transfer	-	●	●
	Configuration data transfer to Dell technical support	-	●	●
Online collaboration	Online collaborative platform in TechDirect for planning, managing and tracking delivery	-	●	●

¹ Choose from onsite hardware installation or a guided option including project specific instructions, documentation and live expert guidance

² Post deployment use for intelligent, automated support & insights

Figure 20. ProDeploy Infrastructure Suite - Field services

Supplemental Deployment Services

Additional ways to expand scope or deploy for unique scenarios.

Two Host Adder (requires PD/PDP)

Deploying new storage, compute, or networking devices may require interconnection to other servers (also called hosts). The Dell delivery team will set up four hosts per device as part of every ProDeploy service. For example, if the customer is buying two storage arrays the ProDeploy service will automatically include connectivity of four hosts each (4x2=8 total hosts per project since there are two devices). This supplemental "Two Host Adder" service provides for the configuration of additional hosts above what is already provided as part of the ProDeploy service. In many cases, customers can work with us while we set up the included hosts, so they may understand how to do the rest themselves. Always ask the customer how many hosts are being connected and sell the host adder depending on the customer's technology skillset. Note that this service applies to the connectivity of Dell devices not 3rd party devices.

Additional Deployment Services (ADT) – sold with or without PD/PDP

You can expand the scope of a ProDeploy engagement leveraging Additional Deployment Time (ADT). ADT covers additional tasks above the normal deliverables of the ProDeploy offers. ADT can also be used as a standalone service without ProDeploy. SKUs are available for both Project Management and Technical Resource Expertise. SKUs are sold as blocks of four hours remote or eight hours onsite. The delivery team can help in scoping the number of hours required for additional tasks.

Data Migration Services

Migrating data sets is no easy task. Our experts use proven tools and process to streamline data migrations and avoid compromising data. A customer project manager works with our experienced team of experts to create a migration plan. Data migration is part of every technology upgrade, platform change, and shift to the cloud. You can rely on Dell data migration services to perform a seamless transition.

Residency Services

Certified technical professionals act like an extension of your IT staff to enhance internal capabilities and resources and help you realize faster adoption and maximized ROI of new technology. Residency Services help customers transition to new capabilities quickly by leveraging specific technology skill sets. Residency experts can provide post implementation management and knowledge transfer that is related to a new technology acquisition or day-to-day operational management of the IT infrastructure.

- Global experts available to serve in-person (onsite) or virtual (remote)
- Engagements starting at 2 weeks with flexibility to adjust
- Residency is available for project management needs, and many different technology skills sets such as: Server, storage, Gen AI, networking, security, multi-cloud, data mgmt., and modern workforce application residents

Unique Deployment Scenarios

Custom Deployment Services

When a deployment is beyond the scope of the ProDeploy Infrastructure Suite, you can turn to the custom deployment services team to address complex implementation scenarios and customer unique requirements. The Dell custom deployment team is staffed with solution architects who will assist with customer scoping calls to define the project and develop the statement of work. Custom services can handle a wide range of deployments that can be performed in the factory or onsite. All custom engagement services are requested through SFDC.

Deployment of AI or HPC

Dell provides a number of deploy options for Artificial Intelligence (AI) or High-Performance Computing (HPC) implementations. These complex environments require specialists that understand advanced feature sets. Dell deploys and understands the complexities to optimize the environment. AI and HPC deployments are always scoped as custom service engagements.

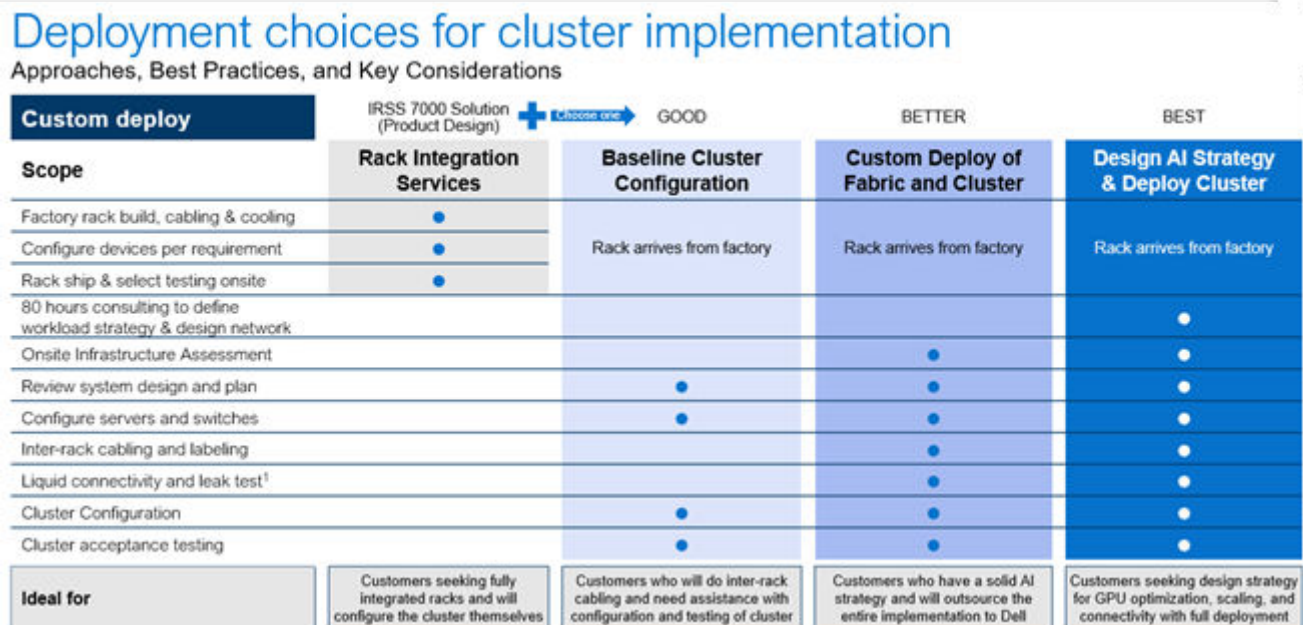

Figure 21. Deployment choices for cluster implementation

DAY 2 – Automation Services with Ansible

Dell solutions are built as “automation ready” with integrated APIs (Application Programming Interfaces) to allow customers to programmatically call actions on the product through code. Although Dell has published Ansible automation use cases,

some customers need additional assistance with GitOps. By the end of the service, the customer will have the foundational components required to accelerate automation and understand how the programming works together: Day 1 and Day 2 use case automation scripts (ansible modules), CI/CD tool (Jenkins), and Version control (Git).

Dell Technologies Consulting Services

Our expert consultants help customers transform faster, and quickly achieve business outcomes for the high-value workloads Dell PowerEdge systems can handle. From strategy to full-scale implementation, Dell Technologies Consulting can help determine how to perform IT, workforce, or application transformation. We use prescriptive approaches and proven methodologies that are combined with the portfolio and partner ecosystem of Dell Technologies to help achieve real business outcomes. From multicloud, applications, DevOps, and infrastructure transformations, to business resiliency, data center modernization, analytics, workforce collaboration, and user experiences-we are here to help.

Dell Managed Services

Some customers prefer Dell to manage the complexity and risk of daily IT operations, Dell Managed Services utilizes proactive, AI enabled delivery operations and modern automation to help customers realize desired business outcomes from their infrastructure investments. With these technologies, our experts run, update, and fine-tune customer environments that are aligned with service levels, while providing environment-wide and down-to-the-device visibility. There are two types of managed service offers. First the outsourcing model or CAPEX model where Dell manages the customer owned assets using our people and tools. The second is the as-a-Service model or OPEX model called APEX. In this service, Dell owns all technology and all the management of it. Many customers will have a blend of the two management types depending on the goals of the organization.

Managed	Outsourcing or CAPEX model	APEX	as-a-Service or OPEX model
<p>We manage your technology using our people and tools.¹</p> <ul style="list-style-type: none"> • Managed detection and response* • Technology Infrastructure • End-user (PC/desktop) • Service desk operations • Cloud Managed (Pub/Private) • Office365 or Microsoft Endpoint 		<p>We own all technology so you can off-load all IT decisions.</p> <ul style="list-style-type: none"> • APEX Cloud Services • APEX Flex on Demand elastic capacity • APEX Data Center Utility pay-per-use model 	

1 – Some minimum device counts may apply. Order via: ClientManagedServices.sales@dell.com

* Managed detection and response covers the security monitoring of laptops, servers, & virtual servers. Min. 50 devices combined. No Networking or Storage-only systems [SAN/NAS]. Available in 32 countries. [Details here](#)

Figure 22. Dell Managed Services

Managed Detection and Response (MDR)

Dell Technologies Managed Detection and Response (MDR) is powered by Secureworks Taegis XDR software platform. MDR is a managed service that secures the customer’s IT environment against malicious actors and provides remediation if and when a threat is identified. When a customer purchases MDR, they will receive the following features from our team:

- Dell badge resources
- Agent rollout assistance to help deploy the Secureworks Endpoint Agent
- 24x7 threat detection and investigation
- Up to 40 hrs per quarter of response and active remediation activities
- If the customer experiences a breach, we will provide up to 40 hrs per year of Cyber incident response initiation
- Quarterly reviews with the customer to review the data

Dell Technologies Education Services

Build the IT skills required to influence the transformational outcomes of the business. Enable talent and empower teams with the right skills to lead and perform transformational strategy that drives competitive advantage. Leverage the training and certification that is required for real transformation.

Dell Technologies Education Services offers PowerEdge server training and certifications that are designed to help customers achieve more from their hardware investment. The curriculum delivers the information and the practical, firsthand skills that their team must confidently install, configure, manage, and troubleshoot Dell servers.

To learn more or register for a class today, see [Education.Dell.com](https://www.dell.com/education).

Resources

[Service for powerEdge](#)

Appendix A: Additional specifications

Topics:

- Chassis dimensions
- System weight
- NIC port specifications
- Video specifications
- USB Ports
- PSU rating
- Environmental specifications

Chassis dimensions

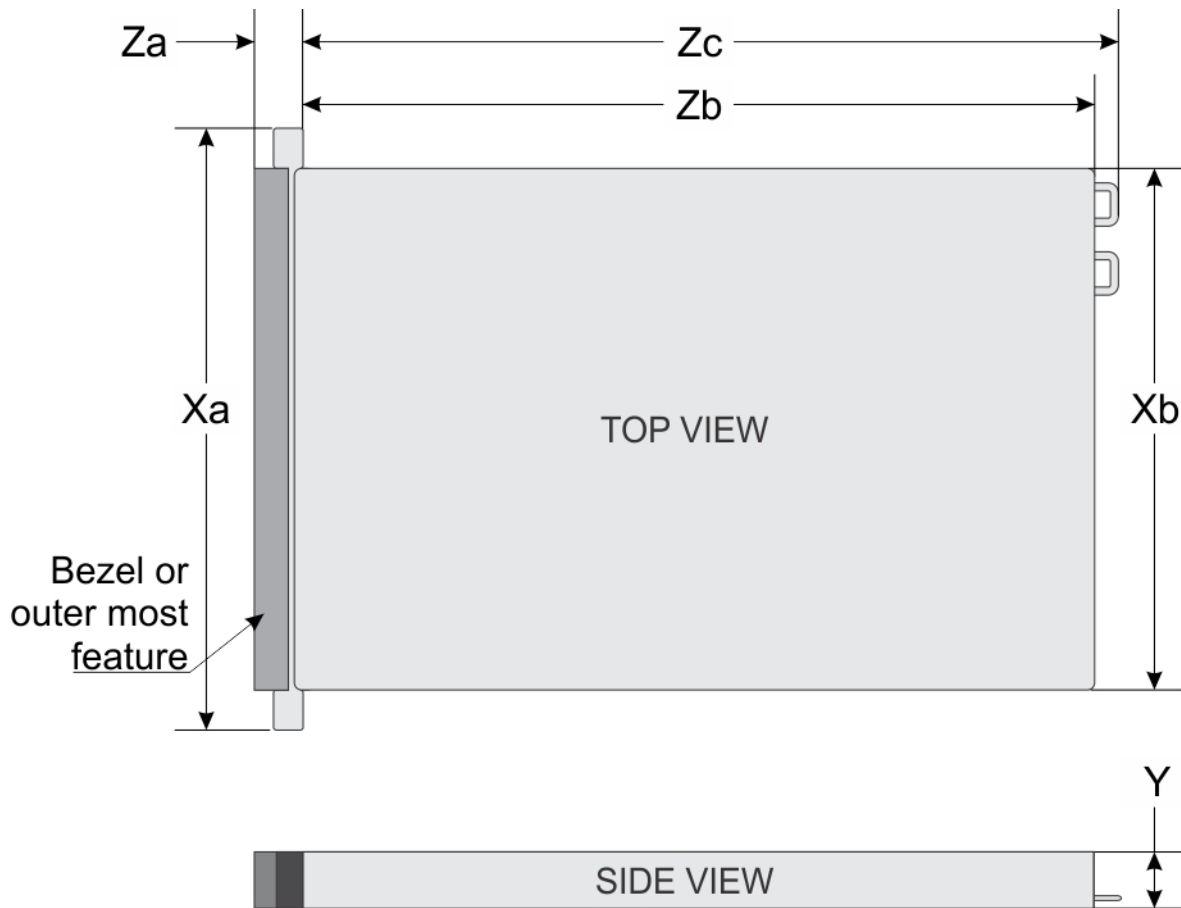

Figure 23. Chassis dimensions

Table 25. PowerEdge R260 chassis dimensions

Drives	Xa	Xb	Y	Za	Zb	Zc
6 drives 2.5 - inch	482.0 mm (18.976 inches)	434.0 mm (17.086 inches)	42.8 mm (1.685 inches)	With bezel 35.6 mm (1.401 inches) Without	426.6 mm (16.795 inches)	461.14 mm (18.155 inches)

Table 25. PowerEdge R260 chassis dimensions (continued)

Drives	Xa	Xb	Y	Za	Zb	Zc
				bezel 22.0 mm (0.866inches)		
2 drives 3.5 - inch	482.0 mm (18.976 inches)	434.0 mm (17.086 inches)	42.8 mm (1.685 inches)	With bezel 35.6 mm (1.401 inches) Without bezel 22.0 mm (0.866inches)	426.6 mm (16.795 inches)	461.14 mm (18.155 inches)

NOTE: Zb is the nominal rear wall external surface where the system board I/O connectors reside.

System weight

Table 26. PowerEdge R260 system weight

System configuration	Maximum weight (with all drives/SSDs)	
A server with fully populated drives and redundant PSU	2.5-inch drives	9.60 kg (21.16 pounds)
	3.5-inch drives	9.61 kg (21.18 pounds)
A server with fully populated drives and cable PSU	2.5-inch drives	9.44 kg (20.81 pounds)
	3.5-inch drives	9.45 kg (20.83 pounds)
A server without drives and redundant PSU installed	2.5-inch drives	7 kg (15.43 pounds)
	3.5-inch drives	6.98 kg (15.38 pounds)
A server without drives and cable PSU installed	2.5-inch drives	6.79 kg (14.96 pounds)
	3.5-inch drives	6.81 kg (15.01 pounds)

NIC port specifications

The system supports up to two 10/100/1000 Mbps Network Interface Controller (NIC) ports embedded on the LAN on Motherboard (LOM) and up to four ports integrated on the optional network cards.

Table 27. NIC port specification for the system

Feature	Specifications
LOM	1 Gb x 2
Network Card (optional)	1 Gb x 4, 10 Gb x 2, 10 Gb x 4

Video specifications

The platform supports the following video resolution and refresh rates.

Table 28. Video specifications for PowerEdge R260

Resolution	Refresh Rate	Sestotal Freq	Pixel Clock	DVO Display Port
640 x 480	60 Hz	31.5 kHz	25.175 MHz	No
640 x 480	72 Hz	37.9 kHz	31.5 MHz	No
640 x 480	75 Hz	37.5 kHz	31.5 MHz	No

Table 28. Video specifications for PowerEdge R260 (continued)

Resolution	Refresh Rate	Sestotal Freq	Pixel Clock	DVO Display Port
640 x 480	85 Hz	43.3 kHz	36.0 MHz	No
800 x 600	60 Hz	37.0 kHz	40.0 MHz	No
800 x 600	72 Hz	48.1 kHz	50.0 MHz	No
800 x 600	75 Hz	46.9 kHz	49.5 MHz	No
800 x 600	85 Hz	53.7 kHz	56.25 MHz	No
1024 x 768	60 Hz	48.4 kHz	65.0 MHz	No
1024 x 768	72 Hz	57.67 kHz	78.43 MHz	No
1024 x 768	75 Hz	60.0 kHz	78.75 MHz	No
1024 x 768	85 Hz	68.7 kHz	94.5 MHz	No
1280 x 800	60 Hz	49.7 kHz	83.5 MHz	No
1280 x 800	75 Hz	62.625 kHz	107.21 MHz	No
1280 x 1024	60 Hz	64.0 kHz	108.0 MHz	No
1280 x 1024	75 Hz	80.0 kHz	135.0 MHz	No
1360 x 768	60 Hz	47.71 kHz	85.5 MHz	No
1440 x 900	60 Hz	55.9 kHz	106.5 MHz	No
1440 x 900	60 Hz (RB)	55.5 kHz	88.75 MHz	No
1600 x 900	60 Hz (RB)	55.54 kHz	97.75 MHz	No
1600 x 900	60 Hz (RB)	60.00 kHz	108.0 MHz	No
1600 x 1200	60 Hz	75.0 kHz	162.0 MHz	No
1600 x 1200	60 Hz (RB)	74.01 kHz	130.25 MHz	No
1680 x 1050	60 Hz	65.3 kHz	146.25 MHz	No
1680 x 1050	60 Hz (RB)	64.7 kHz	119.0 MHz	No
1920 x 1080	60 Hz	67.158 kHz	173.0 MHz	No
1920 x 1080	60 Hz (RB)	66.587 kHz	138.5 MHz	No
1920 x 1200	60 Hz	74.556 kHz	193.25 MHz	No
1920 x 1200	60 Hz (RB)	74.038 kHz	154.00 MHz	No

*DVO - DP is for investigation only, dependent on Nuvoton DVO capabilities to support up to 165MHz.Rear Panel Performance is TBD subject to final board design and losses to rear VGA connector.

*(RB) - Reduced Blanking for Digital Displays requiring less blank time. This was introduced for Signal Integrity improvements by reducing Pixel Clock rates for VGA- Analog input devices.

USB Ports

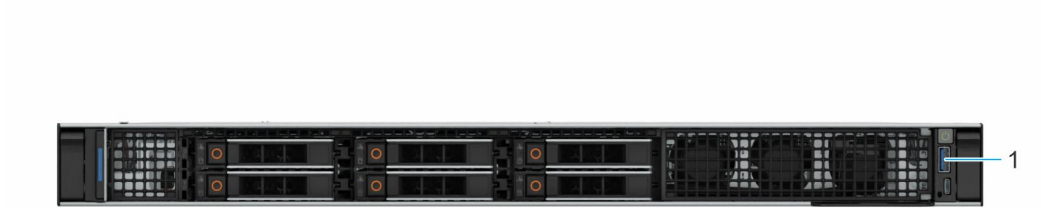

Figure 24. Front USB port

1. USB 2.0 Port



Figure 25. Rear USB ports

1. USB 2.0 Port
2. USB 3.2 Gen1

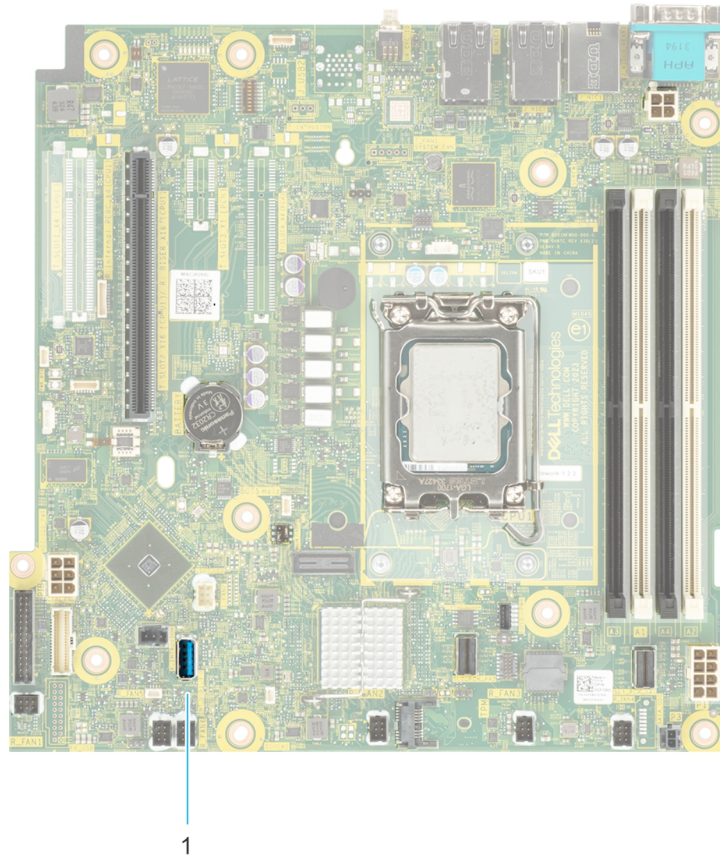

Figure 26. Internal USB Port

1. USB 3.2 Gen1

Table 29. Systems USB Specifications

Front		Rear		Internal	
USB port type	No. of ports	USB port type	No. of ports	USB port type	No. of ports
USB 2.0-compliant port	One	USB 2.0-compliant port	One	Internal USB 3.2 Gen1-compliant port	One
iDRAC Direct port (Micro-AB USB 2.0-compliant port)	One	USB 3.2 Gen1-compliant ports	One		

PSU rating

Below table lists the power capacity the PSUs in high/low line operation mode.

Table 30. PSUs highline and lowline ratings

—	450 W Platinum	700 W Titanium
Peak Power (Highline/-72 VDC)	450 W	700 W
Lowline/-40 VDC	450 W	N/A
Highline 240 VDC	N/A	700 W

Table 30. PSUs highline and lowline ratings (continued)

—	450 W Platinum	700 W Titanium
Highline 200 ~ 380VDC	N/A	N/A
DC -(48 to 60V)	N/A	N/A

The PowerEdge R260 supports up to one AC or DC power supplies, autosensing, and auto switching capability.

Dell PSUs have achieved Titanium or Platinum efficiency levels as shown in the table below.

Table 31. PSU efficiency level

Efficiency Targets by Load						
Form factor	Output	Class	10%	20%	50%	100%
Cabled 106 mm	450W	Platinum	-	90%	94%	91%
Non Cabled 60 mm	700W	Titanium	90%	94%	96%	91%

Environmental specifications

NOTE: For additional information about environmental certifications, refer to the *Product Environmental Datasheet* located with the *Documentation* on [Dell Support Home](#).

Table 32. Continuous Operation Specifications for ASHRAE A2

-	Allowable continuous operations
Temperature range for altitudes <= 900 m (<= 2953 ft)	10–35°C (50–95°F) with no direct sunlight on the equipment
Humidity percent range (non-condensing at all times)	8% RH with -12°C minimum dew point to 80% RH with 21°C (69.8°F) maximum dew point
Operational altitude de-rating	Maximum temperature is reduced by 1°C/300 m (33.8°F/984 Ft) above 900 m (2953 Ft)

Table 33. Continuous Operation Specifications for ASHRAE A3

-	Allowable continuous operations
Temperature range for altitudes <= 900 m (<= 2953 ft)	5–40°C (41–104°F) with no direct sunlight on the equipment
Humidity percent range (non-condensing at all times)	8% RH with -12°C minimum dew point to 85% RH with 24°C (75.2°F) maximum dew point
Operational altitude de-rating	Maximum temperature is reduced by 1°C/175 m (33.8°F/574 Ft) above 900 m (2953 Ft)

Table 34. Continuous Operation Specifications for ASHRAE A4

-	Allowable continuous operations
Temperature range for altitudes <= 900 m (<= 2953 ft)	5–45°C (41–113°F) with no direct sunlight on the equipment
Humidity percent range (non-condensing at all times)	8% RH with -12°C minimum dew point to 90% RH with 24°C (75.2°F) maximum dew point
Operational altitude de-rating	Maximum temperature is reduced by 1°C/125 m (33.8°F/410 Ft) above 900 m (2953 Ft)

Table 35. Common Environmental Specifications for ASHRAE A2, A3, and A4

-	Allowable continuous operations
Maximum temperature gradient (applies to both operation and non-operation)	20°C in an hour* (36°F in an hour) and 5°C in 15 minutes (41°F in 15 minutes), 5°C in an hour* (41°F in an hour) for tape <i>i</i> NOTE: * - Per ASHRAE thermal guidelines for tape hardware, these are not instantaneous rates of temperature change.
Non-operational temperature limits	-40 to 65°C (-104 to 149°F)
Non-operational humidity limits	5% to 95% RH with 27°C (80.6°F) maximum dew point
Maximum non-operational altitude	12,000 meters (39,370 feet)
Maximum operational altitude	3,048 meters (10,000 feet)

Table 36. Maximum vibration specifications

Maximum vibration	Specifications
Operating	0.21 G _{rms} at 5 Hz to 500 Hz (all operation orientations)
Storage	1.88 G _{rms} at 10 Hz to 500 Hz for 15 minutes (all six sides tested)

Table 37. Maximum shock pulse specifications

Maximum shock pulse	Specifications
Operating	Six consecutively executed shock pulses in the positive and negative x, y, and z axis of 6 G for up to 11 ms.
Storage	Six consecutively executed shock pulses in the positive and negative x, y, and z axis (one pulse on each side of the system) of 71 G for up to 2 ms.

Particulate and gaseous contamination specifications

The following table defines the limitations that help avoid any equipment damage or failure from particulates and gaseous contamination. If the levels of particulates or gaseous pollution exceed the specified limitations and result in equipment damage or failure, you must rectify the environmental conditions. Remediation of environmental conditions is the responsibility of the customer.

Table 38. Particulate contamination specifications

Particulate contamination	Specifications
Air filtration: Conventional Data Center only	Data center air filtration as defined by ISO Class 8 per ISO 14644-1 with a 95% upper confidence limit <i>i</i> NOTE: Filtering room air with a MERV8 filter, as specified in ANSI/ASHRAE Standard 127, is a recommended method for achieving the necessary environmental conditions. <i>i</i> NOTE: Air entering the data center must have MERV11 or MERV13 filtration. <i>i</i> NOTE: This condition applies to data center environments only. Air filtration requirements do not apply to IT equipment designed to be used outside a data center, in environments such as an office or factory floor.
Walk-Up Edge Data Center or Cabinet (sealed, closed loop environment)	Filtration is not required for cabinets that are anticipated to be opened six times or less per year. Class 8 per ISO 1466-1 filtration as defined above is required otherwise. <i>i</i> NOTE: In environments commonly above ISA-71 Class G1 or that may have known challenges, special filters may be required.

Table 38. Particulate contamination specifications (continued)

Particulate contamination	Specifications
Conductive dust: data center and non-data center environments	<p>Air must be free of conductive dust, zinc whiskers, or other conductive particles.</p> <p>i NOTE: Conductive dust, which can interfere with equipment operation, can originate from various sources, including manufacturing processes and zinc whiskers that may develop on the plating of raised floor tiles.</p> <p>i NOTE: This condition applies to data center and non-data center environments.</p>
Corrosive dust: data center and non-data center environments	<ul style="list-style-type: none"> Air must be free of corrosive dust. Residual dust present in the air must have a deliquescent point less than 60% relative humidity. <p>i NOTE: This condition applies to data center and non-data center environments.</p>

Table 39. Gaseous contamination specifications

Gaseous contamination	Specifications	Notes
Copper coupon corrosion rate	ISA-71 Class G1: <300 Å/month	Per ANSI/ISA71.04
Silver coupon corrosion rate	ISA-71 Class G1: <200 Å/month	Per ANSI/ISA71.04

Thermal restriction matrix

Table 40. Processor and heat sink matrix

Heat sink	Configuration No
1U HSK	All configurations

Table 41. Label reference

Label	Description
STD	Standard
HPR	High Performance
LP	Low profile
FH	Full height

Table 42. Thermal restriction matrix

Configuration		Configuration 1 3.5 inch Drives Without PCIe card and BOSS-N1	Configuration 2 3.5 inch Drives All Configurations except Configuration 1	Configuration 3 2.5 inch Drives All Configurations	Ambient temperature
CPU TDP/ cTDP	≤ 55 W	3 x STD Fans 1U STD HSK	4 x STD 1U STD HSK	1 x HPR Fan, 5 x STD Fan 1U STD HSK	35°C (95°F)
	55 W ~ 95 W	4 x STD 1U STD HSK	4 x STD 1U STD HSK		35°C (95°F)

NOTE: Refer to the ASHRAE A3/A4 environment specifications under Appendix A for detailed configuration limitation.

Table 43. Fan Location

Chassis	Configuration	Fan Quantity	Fan Location
3.5 inch Drives	For CPU TDP \leq 55 W, No PCIe card, No BOSS	3	Fan 1 (STD fan), Fan 2, Fan 3
3.5 inch Drives	All other configurations except Low power CPU configurations	4	Fan 1 (STD Fan), Fan 2, Fan 3, Fan 4
2.5 inch Drives	All other configurations	6	Fan 1 (HPR), Fan 2, Fan 3, Fan 4, Fan 5, Fan 6

NOTE: Fan 4 is optional and is based on configurations.

NOTE: Fan 2 ~ Fan 6 are STD fan.

Thermal air restrictions

ASHRAE A3/A4 environment

- The operating temperature is for a maximum altitude of 950 m for ASHRAE A3/A4 Cooling.
- If over 950 m, we need to do the ambient temperature de-rating.
- CPU TDP greater than 80 W is not supported.
- BOSS-N1 (M.2) module is not supported.
- Non-Dell qualified peripheral cards and/or peripheral cards greater than 25 W are not supported.

Appendix A. Standards compliance

The system conforms to the following industry standards.

Table 44. Industry standard documents

Standard	URL for information and specifications
ACPI Advance Configuration and Power Interface Specification, v6.4	ACPI
Ethernet IEEE Std 802.3-2022	IEEE Standards
MSFT WHQL Microsoft Windows Hardware Quality Labs	Windows Hardware Compatibility Program
IPMI Intelligent Platform Management Interface, v2.0	IPMI
DDR5 Memory DDR5 SDRAM Specification	JEDEC Standards
PCI Express PCI Express Base Specification, v5.0	PCIe Specifications
PMBus Power System Management Protocol Specification, v1.2	Power System Management Protocol Specification
SAS Serial Attached SCSI, 3 (SAS-3) (T10/INCITS 519)	SCSI Storage Interfaces
SATA Serial ATA Rev. 3.3	SATA IO
SMBIOS System Management BIOS Reference Specification, v3.3.0	DMTF SMBIOS
TPM Trusted Platform Module Specification, v1.2 and v2.0	TPM Specifications
UEFI Unified Extensible Firmware Interface Specification, v2.7	UEFI Specifications
PI Platform Initialization Specification, v1.7	
USB Universal Serial Bus v2.0 and SuperSpeed v3.0 (USB 3.1 Gen1)	USB Implementers Forum, Inc. USB
NVMe Express Base Specification. Revision 2.0c	NVMe
NVMe Command Set Specifications	
1. NVM Express NVM Command Set Specification. Revision 1.1c	
2. NVM Express Zoned Namespaces Command Set. Revision 1.0c	
3. NVM Express® Key Value Command Set. Revision 1.0c	
NVMe Transport Specifications	
1. NVM Express over PCIe Transport. Revision 1.0c	
2. NVM Express RDMA Transport Revision. 1.0b	
3. NVM Express TCP Transport. Revision 1.0c	
NVMe NVM Express Management Interface. Revision 1.2c	
NVMe NVMe Boot Specification. Revision 1.0	

Appendix C Additional resources

Table 45. Additional resources

Resource	Description of contents	Location
Installation and Service Manual	<p>This manual, available in PDF format, provides the following information:</p> <ul style="list-style-type: none"> • Chassis features • System Setup program • System indicator codes • System BIOS • Remove and replace procedures • Diagnostics • Jumpers and connectors 	Dell.com/Support/Manuals
Getting Started Guide	<p>This guide ships with the system, and is also available in PDF format. This guide provides the following information:</p> <ul style="list-style-type: none"> • Initial setup steps 	Dell.com/Support/Manuals
Rack Installation Guide	<p>This document ships with the rack kits, and provides instructions for installing a server in a rack.</p>	Dell.com/Support/Manuals
System Information Label	<p>The system information label documents the system board layout and system jumper settings. Text is minimized due to space limitations and translation considerations. The label size is standardized across platforms.</p>	Inside the system chassis cover
QR code for system resources	<p>This code on the chassis can be scanned by a phone application to access additional information and resources for the server, including videos, reference materials, service tag information, and Dell contact information.</p>	Inside the system chassis cover
Enterprise Infrastructure Planning Tool (EIPT)	<p>The Dell online EIPT enables easier and more meaningful estimates to help you determine the most efficient configuration possible. Use EIPT to calculate the power consumption of your hardware, power infrastructure, and storage.</p>	Dell.com/calc