

Dell PowerEdge R6615

Technical Guide

Notes, cautions, and warnings

 **NOTE:** A NOTE indicates important information that helps you make better use of your product.

 **CAUTION:** A CAUTION indicates either potential damage to hardware or loss of data and tells you how to avoid the problem.

 **WARNING:** A WARNING indicates a potential for property damage, personal injury, or death.

Chapter 1: System overview	5
Key workloads.....	5
New technologies.....	5
Chapter 2: System features and generational comparison	7
Chapter 3: Chassis views and features	10
Front view of the system.....	10
Rear view of the system.....	11
Inside the system.....	12
Chapter 4: Processor	17
Processor features.....	17
Chapter 5: Memory subsystem	18
Supported memory.....	18
Chapter 6: Storage	19
Storage controllers.....	19
Supported Drives.....	19
Internal storage configuration.....	20
External Storage.....	21
Chapter 7: Networking	22
Overview.....	22
OCP 3.0 support.....	22
Supported OCP cards.....	22
OCP NIC 3.0 vs. rack Network Daughter Card comparisons.....	23
Chapter 8: PCIe subsystem	24
PCIe risers.....	24
Chapter 9: Power, thermal, and acoustics	30
Power.....	30
Power Supply Units.....	31
Thermal.....	32
Thermal design.....	32
Acoustics.....	33
Acoustical performance.....	33
Chapter 10: Rack, rails, and cable management	36
Rails and cable management information.....	36

Chapter 11: Operating Systems and Virtualization.....	45
Supported Operating Systems.....	45
Chapter 12: Dell Systems Management.....	46
Integrated Dell Remote Access Controller (iDRAC).....	46
Systems Management software support matrix.....	47
Chapter 13: Appendix A. Additional specifications.....	49
Chassis dimensions	49
System weight.....	50
NIC port specifications.....	50
Video specifications.....	50
USB ports specifications.....	51
PSU rating.....	52
Environmental specifications.....	53
Cooling components.....	55
Particulate and gaseous contamination specifications.....	55
Thermal restriction matrix.....	56
Thermal air restrictions.....	58
Chapter 14: Appendix B. Standards compliance.....	60
Chapter 15: Appendix C Additional resources.....	61
Chapter 16: Appendix D: Service and support.....	62
Why attach service contracts.....	62
ProSupport Infrastructure Suite	62
Specialty Support Services.....	64
ProDeploy Infrastructure Suite.....	65
Supplemental Deployment Services	68
Unique Deployment Scenarios.....	69
DAY 2 – Automation Services with Ansible.....	70
Dell Technologies Consulting Services.....	71

System overview

The PowerEdge R6615 system is a 1U server that supports:

- One AMD EPYC 4th Generation 9004 series processor with up to 128 cores
- 12 DDR5 DIMM slots, supports maximum 3 TB
- Two redundant AC or DC power supply units
- Up to 10 x 2.5-inch SAS/SATA/NVMe drives or 8 x 2.5-inch NVMe SSD drives or 4 x 3.5-inch SATA/SAS drives or 2 x 2.5-inch (rear) SAS/SATA (HDD/SSD) drives
- Up to 16 x E3.S NVMe Gen5 or 14 x E3.S NVMe Gen5 or 2 x E3.S (rear) NVMe Gen5 direct drives
- PCI Express® (PCIe) 5.0 enabled expansion slots
- Network interface technologies to cover Network Interface Card (NIC)
- Optional Direct Liquid Cooling for required CPUs and/or configurations

NOTE: For more information about how to hot swap NVMe PCIe SSD U.2 device, see the *Dell Express Flash NVMe PCIe SSD User's Guide* at [Dell Support](#) page > **Browse all Products** > **Data Center Infrastructure** > **Storage Adapters & Controllers** > **Dell PowerEdge Express Flash NVMe PCIe SSD** > **Documentation** > **Manuals and Documents**.

NOTE: All instances of SAS, SATA drives are referred to as drives in this document, unless specified otherwise.

CAUTION: Do not install GPUs, network cards, or other PCIe devices on your system that are not validated and tested by Dell. Damage caused by unauthorized and invalidated hardware installation will null and void the system warranty.

Topics:

- [Key workloads](#)
- [New technologies](#)

Key workloads

Customers looking for accelerated compute to maximize performance in a dense, scalable server architecture to address the following applications:

- High Performance Computing
- Virtual Desktop Infrastructure (VDI)
- Virtualization

New technologies

Table 1. New technologies

Technology	Detailed Description
AMD Genoa Processor (SP5)	Core count: Up to 128 core processor
	5 nm process technology
	AMD Inter-chip global memory interconnect (xGMI) up to 64 lanes
	Speeds up to 4.1 GHz
	Maximum TDP: 400 W
4800 MT/s DDR5 Memory	Up to 12 channels with 1 DPC per CPU and 12 DIMMs in total

Table 1. New technologies (continued)

Technology	Detailed Description
	Supports DDR5 ECC RDIMM
PCIe Gen	Gen5 @32 GT/s
PCIe Slot	Up to three PCIe Slots with x 8 or x 16 lanes
Flex I/O	<p>LOM board, 2 x1Gb with BCM5720 LAN controller (optional)</p> <p>Rear I/O with:</p> <ul style="list-style-type: none"> ● 1 x Dedicated iDRAC Ethernet port ● 1 x USB 3.0 ● 1 x USB 2.0 ● 1 x VGA (optional for Direct Liquid Cooling configuration) <p>Serial Port Option with STD RIO board</p> <p>OCP Mezz 3.0 (supported by x8 PCIe lanes) (optional)</p> <p>Front I/O with:</p> <ul style="list-style-type: none"> ● 1 x iDRAC Direct (Micro-AB USB) port ● 1 x USB 2.0 ● 1x VGA
CPLD 1-wire	Support payload data of Front PERC, Riser, BOSS N1, BP, and Rear I/O to BIOS and iDRAC.
Dedicated PERC	<p>PERC 11</p> <ul style="list-style-type: none"> ● HBA355i, H355, H755, H755N <p>PERC 12</p> <ul style="list-style-type: none"> ● H965i ● H965e ● HBA465i ● HBA465e
Software RAID	S160
Power Supplies	<p>The 60 mm dimension is the same PSU form factor with 15G on 16G design.</p> <p>Titanium 700 W AC/HVDC</p> <p>Platinum 800 W AC/HVDC</p> <p>Titanium 1100 W AC/HVDC</p> <p>Platinum 1400 W AC/HVDC</p> <p>Titanium 1400 W AC/HVDC</p> <p>Titanium 1800 W AC/HVDC</p> <p>1100 W -48 LVDC</p>

System features and generational comparison

The following table shows the comparison between the PowerEdge R6615 with the PowerEdge R6515.

Table 2. Features comparison

Features	PowerEdge R6615	PowerEdge R6515
Processors	One AMD® EPYC 4th Generation Genoa (SP5) processor	One AMD® EPYC™ 3rd Generation Rome (SP3) processor
Processor interconnect	Inter-chip global memory interconnect (xGMI) 32 GT/sec	Inter-chip global memory interconnect (xGMI) 16 GT/s
Memory	12 x DDR5 RDIMM (3 TB), bandwidth up to 4800 MT/S	16 x DDR4 RDIMM (1 TB), LRDIMM (2 TB), bandwidth up to 3200 MT/S
Storage Controllers	<ul style="list-style-type: none"> • PERC: HBA355i, H355, H755, H755N, H965i, BHA465i • External adapters: HBA355e, BHA465e, H965e • Software RAID: S160 • BOSS-N1 	<ul style="list-style-type: none"> • PERC: HBA330, H330, H730P • External adapter: H840, HBA355e • Software RAID: S150 • BOSS S1
Drive Bays	<p>Front bays:</p> <ul style="list-style-type: none"> • Up to 4 x 3.5-inch SAS/SATA (HDD/SSD) max 80 TB • Up to 8 x 2.5-inch NVMe SSD max 122.88 TB • Up to 10 x 2.5-inch SAS/SATA/NVMe (HDD/SSD) max 153.6 TB • Up to 14 x E3.S (NVMe Gen5) max 107.52 TB • Up to 16 x E3.S (NVMe Gen5) max 122.88 TB <p>Rear bays:</p> <ul style="list-style-type: none"> • Up to 2 x 2.5-inch SAS/SATA (HDD/SSD) max 30.72 TB • Up to 2 x E3.S (NVMe Gen5) max 15.36 TB 	<p>Front bays:</p> <ul style="list-style-type: none"> • Up to 4 x 3.5-inch SAS/SATA (HDD/SSD) max 64 TB • Up to 8 x 2.5-inch SAS/SATA (HDD/SSD) max 19.2 TB • Up to 10 x 2.5-inch NVMe max 76.8 TB <p>Rear bay:</p> <ul style="list-style-type: none"> • N/A
Power Supplies	<ul style="list-style-type: none"> • 1800 W Titanium 200-240 VAC or 240 HVDC • 1400 W Platinum 100-240 VAC or 240 HVDC • 1400 W Titanium 100-240 VAC or 240 HVDC • 1400 W Titanium 277 VAC or 336 HVDC • 1100 W Titanium 100-240 VAC or 240 HVDC • 1100 W LVDC -48 - -60 VDC • 800 W Platinum 100-240 VAC or 240 HVDC • 700 W Titanium 200-240 VAC or 240 HVDC <p>Hot swap PSUs with full redundancy.</p>	<ul style="list-style-type: none"> • 700 W Platinum 100-240 VAC or 240 HVDC • 5500 W Platinum 200-240 VAC or 240 HVDC <p>Hot swap PSUs with full redundancy.</p>

Table 2. Features comparison (continued)

Features	PowerEdge R6615	PowerEdge R6515		
Cooling Options	<ul style="list-style-type: none"> Air Cooling Optional Direct Liquid Cooling (DLC) <p>i NOTE: DLC is a rack solution and requires rack manifolds and a cooling distribution unit (CDU) to operate.</p>	<ul style="list-style-type: none"> Air Cooling 		
Fans	Up to four sets (dual fan module) Standard (STD) / High Performance Gold (HPR Gold) hot plug fans	Up to three sets (dual fan module) Standard (STD) / High performance (HPR) hot plug fans		
Dimension	Height: 42.8 mm (1.685 inches)	Height: 42.8 mm (1.685 inches)		
	Width: 482 mm (18.97 inches)	Width: 482 mm (18.97 inches)		
	Depth: 772.13 mm (30.39 inches) with bezel	Depth: 728.46 mm (28.67 inches) with bezel		
	Depth: 758.29 mm (29.85 inches) without bezel	Depth: 714.62 mm (28.13 inches) without bezel		
Form Factor	1U rack server	1U rack server		
Embedded Management	<ul style="list-style-type: none"> iDRAC9 iDRAC Direct iDRAC RESTful API with Redfish iDRAC Service Manual Quick Sync 2 wireless module 	<ul style="list-style-type: none"> iDRAC9 iDRAC Direct iDRAC RESTful API with Redfish iDRAC Service Manual Quick Sync 2 wireless module 		
Bezel	Optional LCD bezel or security bezel	Optional LCD bezel or security bezel		
OpenManage Software	<ul style="list-style-type: none"> OpenManage Enterprise OpenManage Power Manager plug-in OpenManage Services plug-in OpenManage Update Manager plug-in 	<ul style="list-style-type: none"> OpenManage Enterprise OpenManage Power Manager plug-in OpenManage Services plug-in OpenManage Update Manager plug-in 		
Mobility	OpenManage Mobile	OpenManage Mobile		
Integrations and Connections	OpenManage Integrations <ul style="list-style-type: none"> Microsoft System Center Red Hat Ansible Modules VMware vCenter and vRealize Operations Manager 	<table border="1"> <tr> <td> OpenManage Integrations <ul style="list-style-type: none"> Microsoft System Center Red Hat Ansible Modules VMware vCenter </td> <td> OpenManage Connections <ul style="list-style-type: none"> Micro Focus Operations Manager </td> </tr> </table>	OpenManage Integrations <ul style="list-style-type: none"> Microsoft System Center Red Hat Ansible Modules VMware vCenter 	OpenManage Connections <ul style="list-style-type: none"> Micro Focus Operations Manager
OpenManage Integrations <ul style="list-style-type: none"> Microsoft System Center Red Hat Ansible Modules VMware vCenter 	OpenManage Connections <ul style="list-style-type: none"> Micro Focus Operations Manager 			
Security	<ul style="list-style-type: none"> AMD Secure Encrypted Virtualization (SEV) AMD Secure Memory Encryption (SME) Cryptographically signed firmware Data at Rest Encryption (SEDs with local or external key mgmt) Secure Boot Secure Erase Secured Component Verification (Hardware integrity check) Silicon Root of Trust System Lockdown (requires iDRAC9 Enterprise or Datacenter) TPM 2.0 FIPS, CC-TCG certified, TPM 2.0 China NationZ 	<ul style="list-style-type: none"> AMD Secure Encrypted Virtualization (SEV) AMD Secure Memory Encryption (SME) Cryptographically signed firmware Secure Boot Secure Erase Silicon Root of Trust System Lockdown (requires iDRAC9 Enterprise or Datacenter) TPM 1.2/2.0 FIPS, CC-TCG certified, TPM 2.0 China NationZ 		
Embedded NIC	2 x 1GbE LOM card (optional)	2 x 1GbE LOM card (optional)		

Table 2. Features comparison (continued)

Features	PowerEdge R6615	PowerEdge R6515				
Networking Options	1 x OCP card 3.0 (optional) ⓘ NOTE: The system allows either LOM card or OCP card or both to be installed in the system.	1 x OCP 3.0 (optional) ⓘ NOTE: The system allows either LOM card or OCP card or both to be installed in the system.				
GPU Options	Up to 2 x 75 W (SW)					
Ports	<table border="1" style="width: 100%; border-collapse: collapse;"> <tr> <td style="width: 50%; padding: 5px;"> Front Ports <ul style="list-style-type: none"> ● 1 x Dedicated iDRAC micro-USB ● 1 x USB 2.0 ● 1 x VGA </td> <td style="width: 50%; padding: 5px;"> Rear Ports <ul style="list-style-type: none"> ● 1 x USB 2.0 ● 1 x iDRAC Direct/Ethernet port ● 1 x USB 3.0 ● 1 x VGA (optional for liquid cooling configuration) </td> </tr> </table>	Front Ports <ul style="list-style-type: none"> ● 1 x Dedicated iDRAC micro-USB ● 1 x USB 2.0 ● 1 x VGA 	Rear Ports <ul style="list-style-type: none"> ● 1 x USB 2.0 ● 1 x iDRAC Direct/Ethernet port ● 1 x USB 3.0 ● 1 x VGA (optional for liquid cooling configuration) 	<table border="1" style="width: 100%; border-collapse: collapse;"> <tr> <td style="width: 50%; padding: 5px;"> Front Ports <ul style="list-style-type: none"> ● 1 x Dedicated iDRAC micro-USB ● 1 x USB 2.0 ● 1 x VGA </td> <td style="width: 50%; padding: 5px;"> Rear Ports <ul style="list-style-type: none"> ● 1 x iDRAC Direct/Ethernet port ● 2 x USB 3.0 ● 1 x Serial port (optional) ● 1 x VGA </td> </tr> </table>	Front Ports <ul style="list-style-type: none"> ● 1 x Dedicated iDRAC micro-USB ● 1 x USB 2.0 ● 1 x VGA 	Rear Ports <ul style="list-style-type: none"> ● 1 x iDRAC Direct/Ethernet port ● 2 x USB 3.0 ● 1 x Serial port (optional) ● 1 x VGA
	Front Ports <ul style="list-style-type: none"> ● 1 x Dedicated iDRAC micro-USB ● 1 x USB 2.0 ● 1 x VGA 	Rear Ports <ul style="list-style-type: none"> ● 1 x USB 2.0 ● 1 x iDRAC Direct/Ethernet port ● 1 x USB 3.0 ● 1 x VGA (optional for liquid cooling configuration) 				
Front Ports <ul style="list-style-type: none"> ● 1 x Dedicated iDRAC micro-USB ● 1 x USB 2.0 ● 1 x VGA 	Rear Ports <ul style="list-style-type: none"> ● 1 x iDRAC Direct/Ethernet port ● 2 x USB 3.0 ● 1 x Serial port (optional) ● 1 x VGA 					
Internal Port: 1 x USB 3.0	Internal Port: 1 x USB 3.0					
PCIe	Up to three PCIe slots <ul style="list-style-type: none"> ● 2 x PCIe Gen5 slots ● 3 x PCIe Gen4 slots 	Up to two PCIe slots <ul style="list-style-type: none"> ● 1 x PCIe Gen 4 slots ● 1 x PCIe Gen 3 slots 				
Operating System and Hypervisors	<ul style="list-style-type: none"> ● Canonical Ubuntu Server LTS ● Microsoft Windows Server with Hyper-V ● Red Hat Enterprise Linux ● SUSE Linux Enterprise Server ● VMware ESXi For specifications and interoperability details, see Dell Enterprise Operating Systems on Servers, Storage, and Networking page at Dell.com/OSsupport .	<ul style="list-style-type: none"> ● Canonical Ubuntu Server LTS ● Citrix Hypervisor ● Windows Server LTSC with Hyper-V ● Red Hat Enterprise Linux ● SUSE Linux Enterprise Server ● VMware ESXi For specifications and interoperability details, see Dell Enterprise Operating Systems on Servers, Storage, and Networking page at Dell.com/OSsupport .				

Chassis views and features

Topics:

- Front view of the system
- Rear view of the system
- Inside the system

Front view of the system



Figure 1. Front view of 4 x 3.5-inch drive system



Figure 2. Front view of 8 x 2.5-inch drive system



Figure 3. Front view of 10 x 2.5-inch drive system



Figure 4. Front view of 14 x EDSFF E3.S drive system



Figure 5. Front view of 16 x EDSFF E3.S drive system

Rear view of the system



Figure 6. Rear view of the system with no risers



Figure 7. Rear view of the system with 2 x 2.5-inch rear drive system

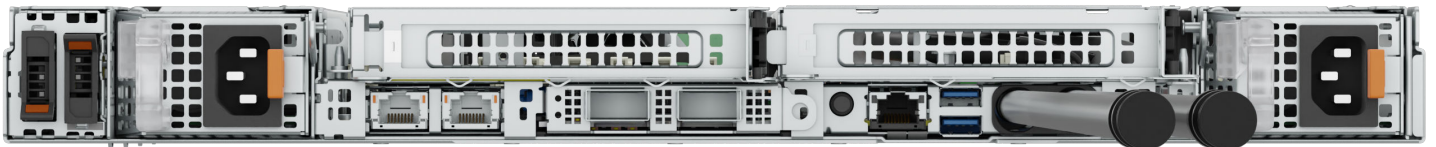
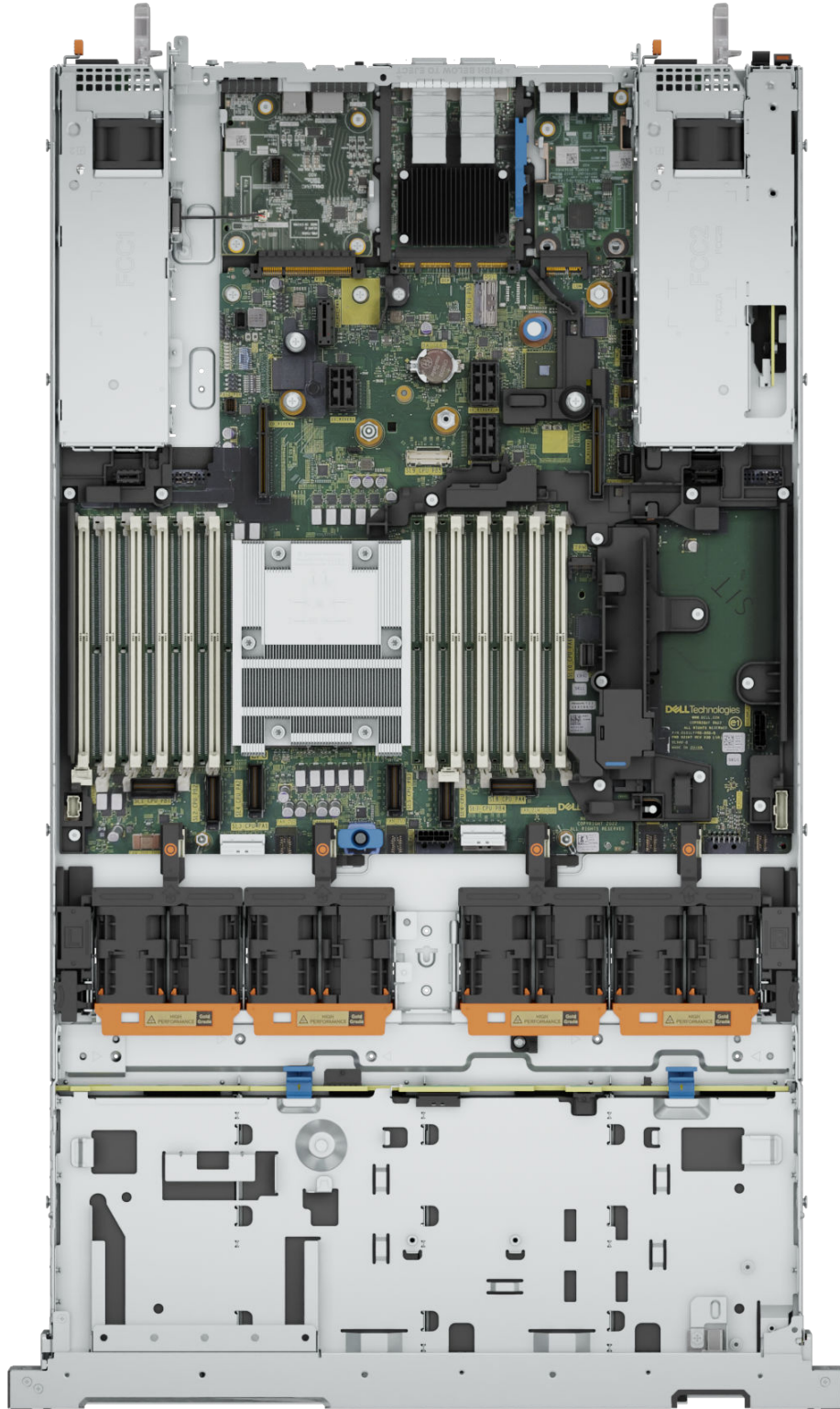

Figure 8. Rear view of the system with Direct Liquid Cooling module



Figure 9. Rear view of the system with 2 x E3.S rear drive system

Inside the system



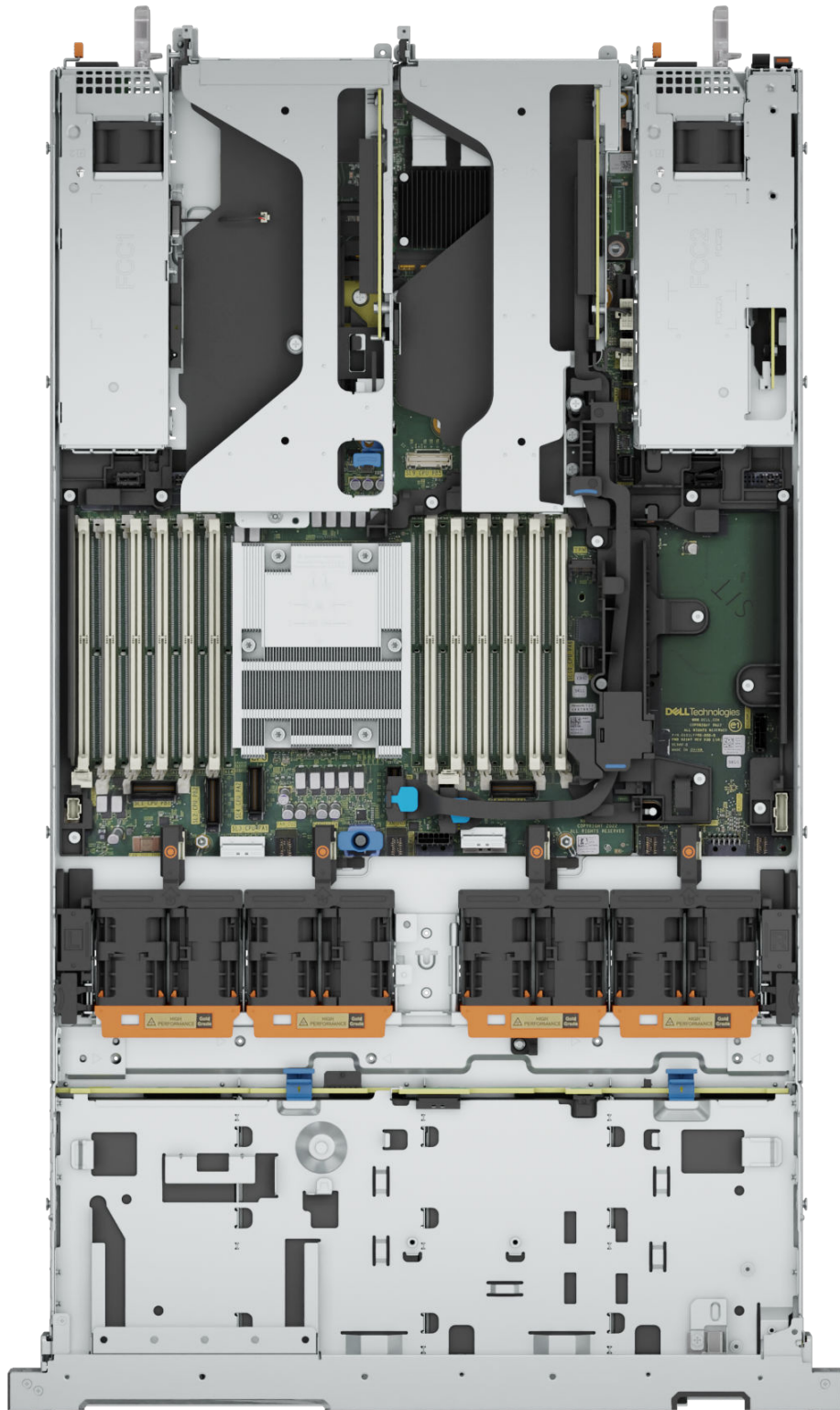

Figure 11. Inside the system with Risers

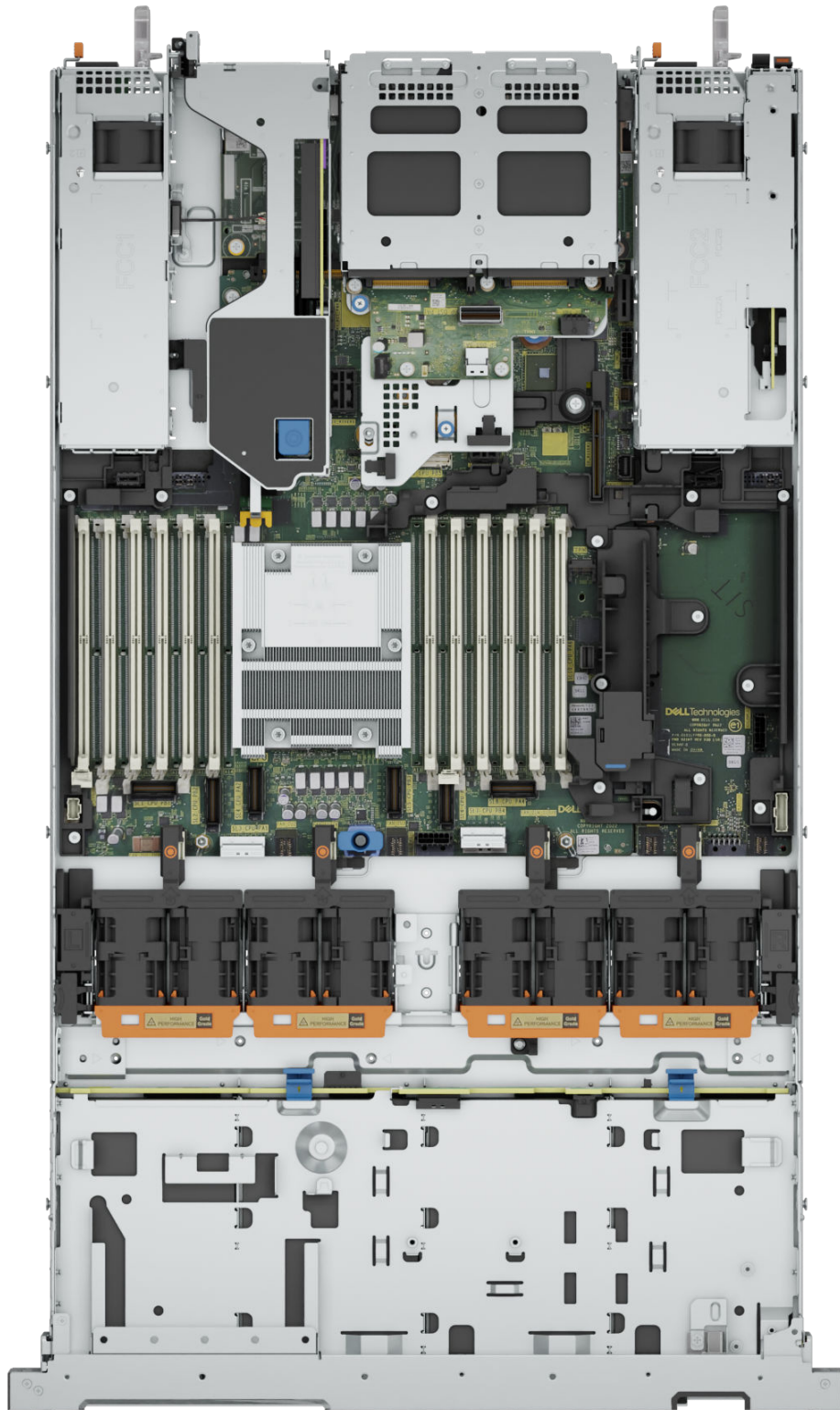

Figure 12. Inside the system with Risers + Rear 2 x 2.5-inch module

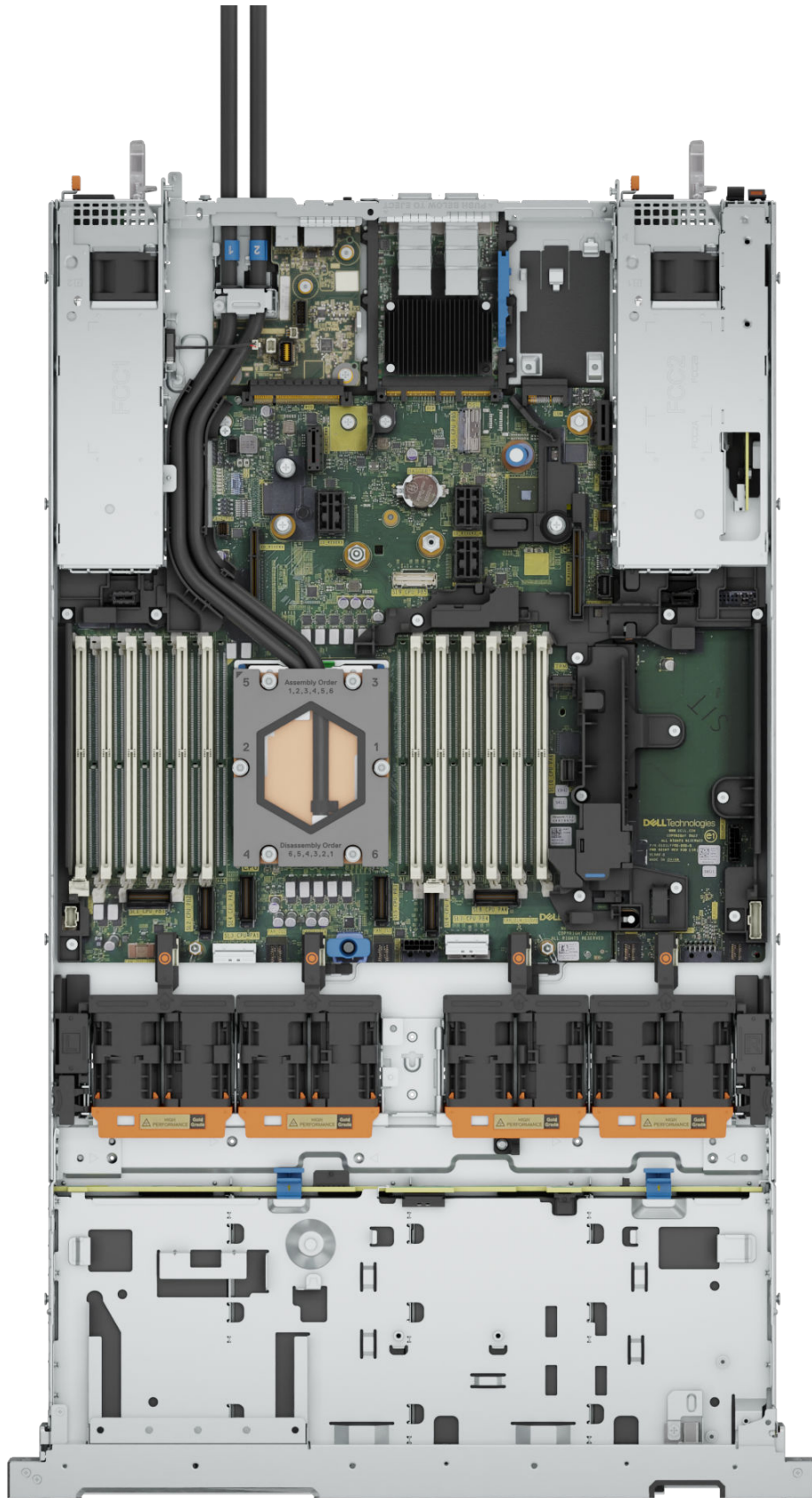

Figure 13. Inside the system with Direct Liquid Cooling module

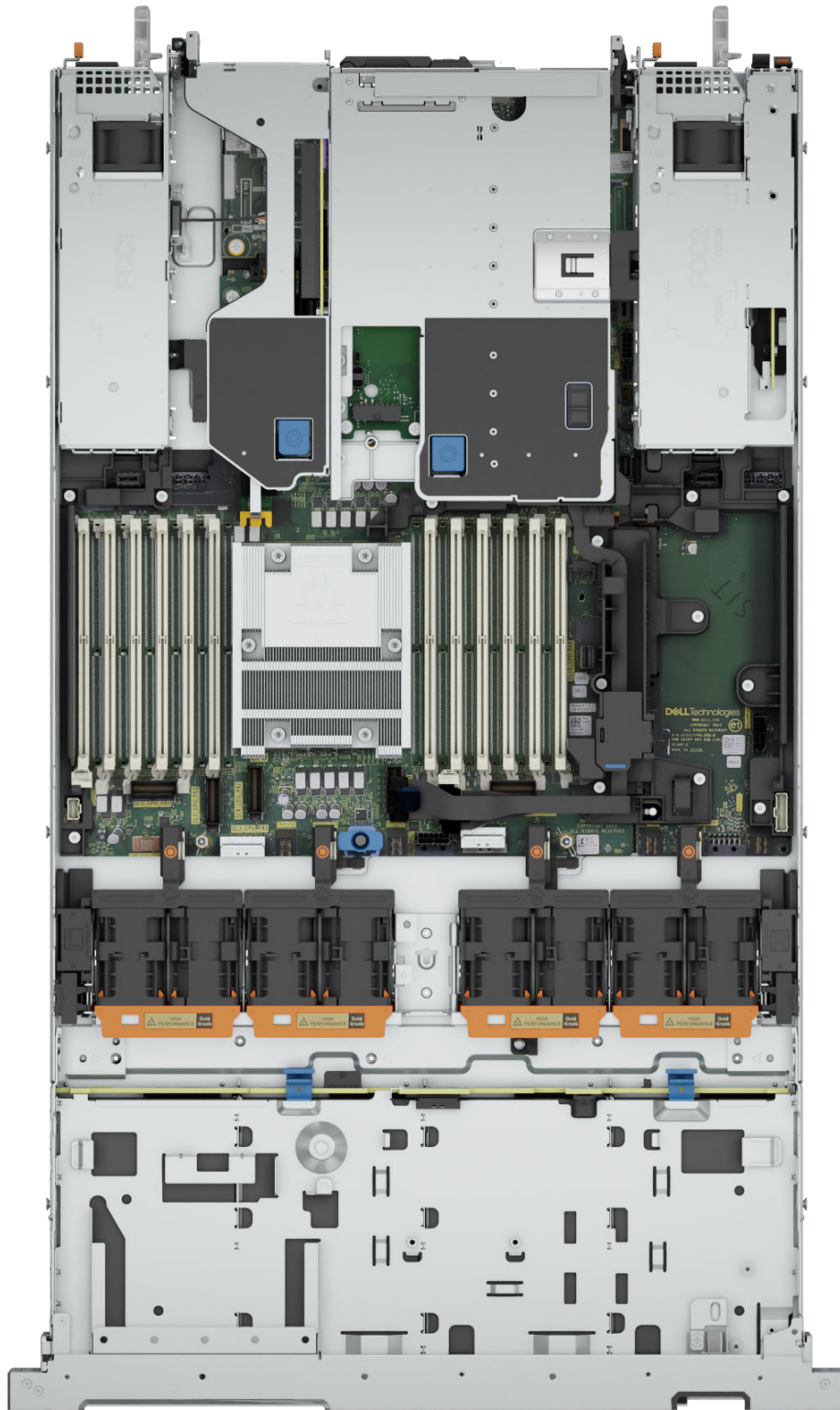

Figure 14. Inside the system with Risers + Rear 2 x E3.S

Processor

Topics:

- [Processor features](#)

Processor features



The AMD EPYC™9004 Series Processor ("Genoa") is the 4th Generation AMD EPYC™ System on a chip (SOC) supporting the modern data center. The AMD EPYC™ 9004 Series Processor is based on AMD's SP5 compatible socket infrastructure with a new BIOS. AMD EPYC™9004 Series Processor is not drop-in compatible to AMD's SP3 socket infrastructure for EPYC™ Series 7002 ("Rome") and 7003 ("Milan") Processors. Based on AMD's "Zen4" and "Zen4c" cores, integrated I/O controllers, up to 32 MB of L3 cache per core, advanced security, and synchronized fabric and memory clock speeds, "Genoa" is designed for improved performance, lower TCO, and faster time to results with next gen technologies.

The following lists the features and functions included in the AMD Genoa offering:

- Supports AMD Zen4c CPU up to 128 cores and AMD Zen4 CPU up to 96 cores with enhance performance with 32 MB L3 cache/core. Integrated I/O support for up to 128 lanes with PCI Express 5.
- Enhanced Memory Performance with support up to 4800 MT/s DIMMs (1 DPC), and RDIMM support. Enhanced Memory Performance with: Infinity Fabric™ and Memory Clock Synchronized. Largest Available x86 L3 Cache – up to 32 MB/core.
- Memory Capacity with up to 12 channels DDR5 and up to 256 GB/channel support with 2, 4, 6, 8, 10 and 12 channel performance optimization options.
- Enhanced physical and virtual security with AMD Infinity Guard that includes silicon embedded security and virtual features (Secure Memory Encryption and Secure Encrypted Virtualization-Secure Nested Paging (SEV-SNP)).

Memory subsystem

Topics:

- [Supported memory](#)

Supported memory

The R6615 supports up to 12 DIMMs, with up to 3 TB of memory and speeds of up to 4800 MT/s.

The R6615 support registered (RDIMMs), allowing for the maximum platform memory capacity. Unbuffered DIMMs (UDIMMs) are not supported.

Table 3. Memory technology comparison

Feature	PowerEdge R6615 (DDR5)
DIMM type	RDIMM
Transfer speed	4800 MT/s
Voltage	1.1 V

 **NOTE:** The processor may reduce the performance of the rated DIMM speed.

Storage

Topics:

- [Storage controllers](#)
- [Supported Drives](#)
- [Internal storage configuration](#)
- [External Storage](#)

Storage controllers

Dell's RAID controller options offer performance improvements, including the fPERC solution. fPERC provides a base RAID HW controller without consuming a PCIe slot by using a small form factor and high-density connector to the base planar. 16G PERC Controller offerings will be a heavy leverage of 15G PERC family. The Value and Value Performance levels will carry over to 16G from 15G. New to 16G, is the Harpoon-based Premium Performance tier offering. This high-end offering will drive IOPs performance and enhanced SSD performance.

NOTE: The size of the RAID 1 drives must be less than that of the second RAID container.

Table 4. PERC Series controller offerings

Performance Level	Controller and Description
Entry	S160
Value	H355, HBA355 (Internal/External), HBA465 (Internal/External)
Premium Performance	H755, H755N, H965 (Internal/External)

NOTE: For more information on the features of the Dell PowerEdge RAID controllers (PERC), Software RAID controllers, or BOSS card, and on deploying the cards, see the storage controller documentation at [Storage Controller Manuals](#).

Supported Drives

The table shown below lists the internal drives that are supported by the R6615.

Table 5. Supported Drives

Form Factor	Type	Speed	Rotational Speed	Capacities
2.5 inches	vSAS	12 Gb	SSD	1.92 TB, 3.84 TB, 960 GB, 7.62 TB
2.5 inches	SAS	24 Gb	SSD	1.92 TB, 1.6 TB, 800 GB, 3.84 TB, 960 GB, 7.68 TB
2.5 inches	SATA	6 Gb	SSD	1.92 TB, 480 GB, 960 GB, 3.84 TB
2.5 inches	NVMe	Gen4	SSD	1.6 TB, 3.2 TB, 6.4 TB, 1.92 TB, 3.84 TB, 15.63 TB, 7.68 TB, 800 GB, 400 GB
2.5 inches	DC NVMe	Gen4	SSD	3.84 TB, 960 GB
2.5 inches	SAS	12 Gb	10 K	600 GB, 1.2 TB, 2.4 TB
3.5 inches	SATA	6 Gb	7.2 K	2 TB, 4 TB, 8 TB, 12 TB, 16 TB, 20 TB

Table 5. Supported Drives (continued)

Form Factor	Type	Speed	Rotational Speed	Capacities
3.5 inches	SAS	12 Gb	7.2 K	2 TB, 4 TB, 8 TB, 12 TB, 16 TB, 20 TB
EDSFF E3.S	NVMe	Gen5	SSD	3.84 TB, 7.68 TB

Internal storage configuration

Table 6. R6615 Internal Storage Configuration Matrix

Total HDD/SSD (not BOSS)	NVMe Enabled/Universal Slots	16G Storage Front	Rear Storage	PERC Qty (f+a)	Storage Controller(s)	Controller Form Factor
0*	0 / 0	N/A	N/A	0+0	N/A	N/A
8	0 / 0	1U 4x3.5-inch Passive	N/A	1+0	HBA355i/H355	Front PERC
12	0 / 0	1U 4x3.5-inch Passive	1U Rear X2 E3.S BP	1+0	HBA355i/H355/S160_NVMe	Front PERC
14	0 / 0	1U 8x2.5 SAS4/SATA RAID	N/A	1+0	HBA355i/H355	Front PERC
14	8 / 0	1U 8x2.5 Universal (SAS4/Gen4)	N/A	0+0	S160_NVMe	N/A
16	8 / 0	1U 8x2.5 Universal (SAS4/Gen4)	N/A	1+0	H755N	Front PERC
16	8 / 0	1U 8x2.5 Universal (SAS4/Gen4)	N/A	1+0	H965i	Front PERC
16	8 / 8	1U 8x2.5 Universal (SAS4/Gen4)	N/A	1+0	HBA355i/H355/H755/S160_NVMe	Front PERC
8	8 / 8	1U 8x2.5 Universal (SAS4/Gen4)	N/A	1+0	H965i/S160_NVMe	Front PERC
8	0 / 0	1U 10x2.5-inch Uni BP (SAS4/Gen4)	N/A	1+0	HBA355i/H355/H755	Front PERC
8	0 / 0	1U 10x2.5-inch Uni BP (SAS4/Gen4)	N/A	1+0	H965i	Front PERC
16	4 / 4	1U 10x2.5-inch Uni BP (SAS4/Gen4)	N/A	1+0	HBA355i/H355/H755/S160_NVMe	Front PERC
16	4 / 4	1U 10x2.5-inch Uni BP (SAS4/Gen4)	N/A	1+0	H965i	Front PERC
16	0 / 0	1U 10x2.5-inch Uni BP (SAS4/Gen4)	1U Rear 2x2.5 Universal Passive (SAS4)	1+0	HBA355i/H355/H755	Front PERC

Table 6. R6615 Internal Storage Configuration Matrix (continued)

Total HDD/ SSD (not BOSS)	NVMe Enabled/ Universal Slots	16G Storage Front	Rear Storage	PERC Qty (f+a)	Storage Controller(s)	Controller Form Factor
16	0 / 0	1U 10x2.5-inch Uni BP (SAS4/ Gen4)	1U Rear 2x2.5 Universal Passive (SAS4)	1+0	H965i	Front PERC
16	10 / 0	1U 10x2.5-inch Uni BP (SAS4/ Gen4)	N/A	0+0	S160_NVMe	N/A
24	0 / 0	1U 10x2.5-inch Uni BP (SAS4/ Gen4)	1U Rear x2 E3.S BP	1+0	HBA355i/ H355/H755/ S160_NVMe	Front PERC
24	0 / 0	1U 10x2.5-inch Uni BP (SAS4/ Gen4)	1U Rear x2 E3.S BP	1+0	H965i/ S160_NVMe	Front PERC
24	10 / 0	1U 10x2.5-inch Uni BP (SAS4/ Gen4)	1U Rear x2 E3.S BP	0+0	S160_NVMe	N/A
24	8 / 0	1U 8xE3.S Passive BP	N/A	0+0	S160_NVMe	N/A
24	8 / 0	1U 8xE3.S w/ fPERC power slot Passive BP	N/A	2+0	H755N	Front PERC
24	8 / 0	1U 8xE3.S w/ fPERC power slot Passive BP	N/A	2+0	H965i	Front PERC
26	8 / 0	1U 8xE3.S Passive BP	N/A	0+0	S160_NVMe	N/A

 **NOTE:** *BOSS Mandatory: All other configurations support optional BOSS.

External Storage

The R6615 support the external storage device types listed in the table below.

Table 7. Support for External Storage Devices

Device Type	Description
External Tape	Supports connection to external USB tape products
NAS/IDM appliance software	Supports NAS software stack
JBOD	Supports connection to 12Gb MD-series JBODs

Networking

Topics:

- [Overview](#)
- [OCP 3.0 support](#)

Overview

PowerEdge offers a wide variety of options to get information moving to and from our servers. Industry best technologies are chosen, and systems management features are added by our partners to firmware to tie in with iDRAC. These adapters are rigorously validated for worry-free, fully supported use in Dell servers.

OCP 3.0 support

Table 8. OCP 3.0 feature list

Feature	OCP 3.0
Form factor	SFF
PCIe Gen	Gen4
Max PCIe width	x8, x16 (with OCP cable)
Max no.of ports	4
Port type	BT/SPF/SFP+/SFP28/SFP56/Q56
Max port speed	25 GbE, 100 GbE (with OCP cable)
NC-SI	Yes
SNAPI	No
WoL	Yes
Power consumption	15-35 W

Supported OCP cards

Table 9. Supported OCP cards

Form Factor	Vendor	Port type	Max Port speed	Port Count
OCP 3.0	Broadcom	Q56	100 GbE	2
	Mellanox	SFP56	100 GbE	2
	Mellanox	SFP28	25 GbE	2
	Broadcom	SFP28	25 GbE	4
	Broadcom	SFP28	25 GbE	2
	Intel	SFP28	25 GbE	2

Table 9. Supported OCP cards (continued)

Form Factor	Vendor	Port type	Max Port speed	Port Count
	Intel	SFP28	25 GbE	4
	Broadcom	BT	10 GbE	4
	Intel	BT	10 GbE	2
	Broadcom	BT	10 GbE	2
	Broadcom	BT	1 GbE	4
	Intel	BT	1 GbE	4
	Intel	BT	1 GbE	4
	Broadcom	BT	1 GbE	4

OCP NIC 3.0 vs. rack Network Daughter Card comparisons

Table 10. OCP 3.0, 2.0, and rNDC NIC comparison

Form Factor	Dell rNDC	OCP 2.0 (LOM Mezz)	OCP 3.0	Notes
PCIe Gen	Gen 3	Gen 3	Gen 4	Supported OCP3 is SFF (small form factor).
Max PCIe Lanes	x8	Up to x16	Up to x16	See server slot priority matrix.
Shared LOM	Yes	Yes	Yes	This is iDRAC port redirect.
Aux Power	Yes	Yes	Yes	Used for Shared LOM

PCIe subsystem

Topics:

- PCIe risers

PCIe risers

Shown below are the riser offerings for the platform.

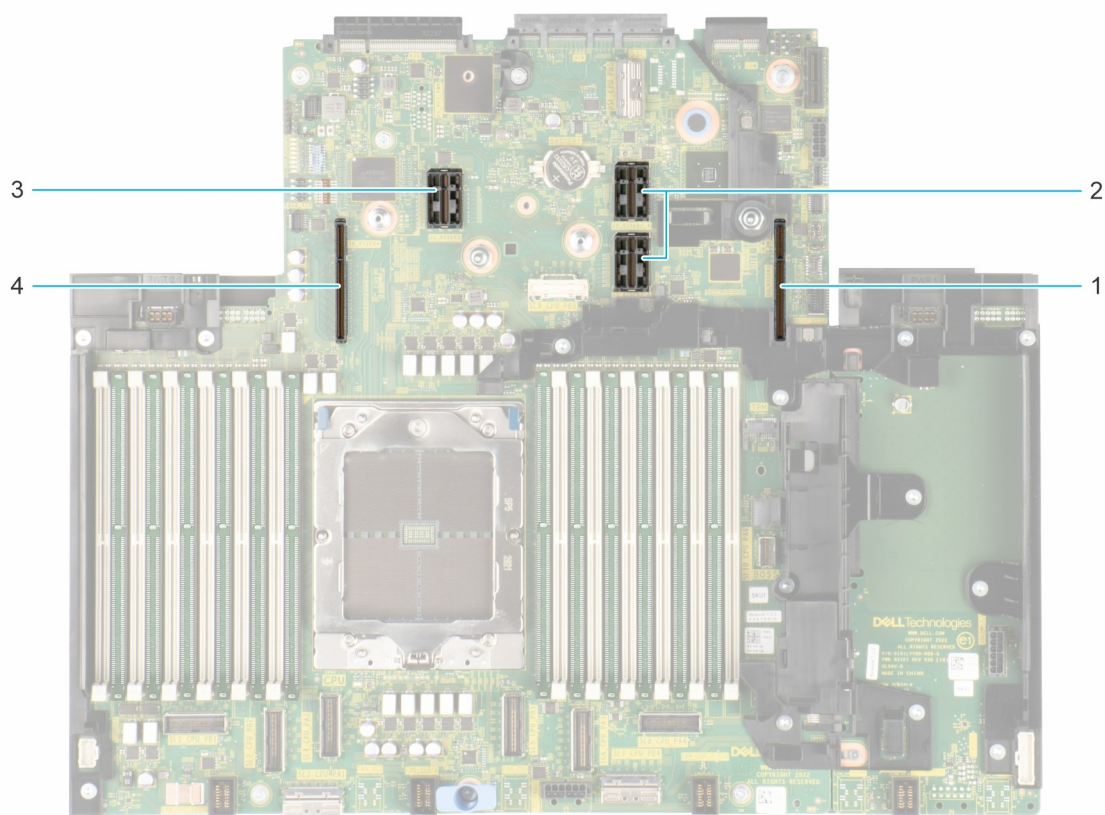

Figure 15. Riser connector location on system board

- | | |
|------------|------------|
| 1. Riser 1 | 2. Riser 2 |
| 3. Riser 3 | 4. Riser 4 |

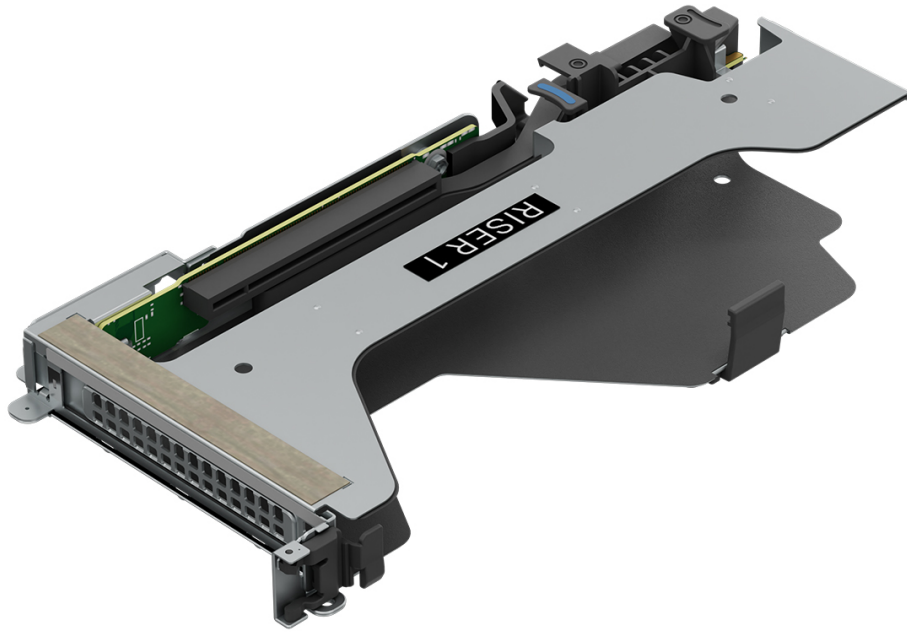

Figure 16. Riser R1Q

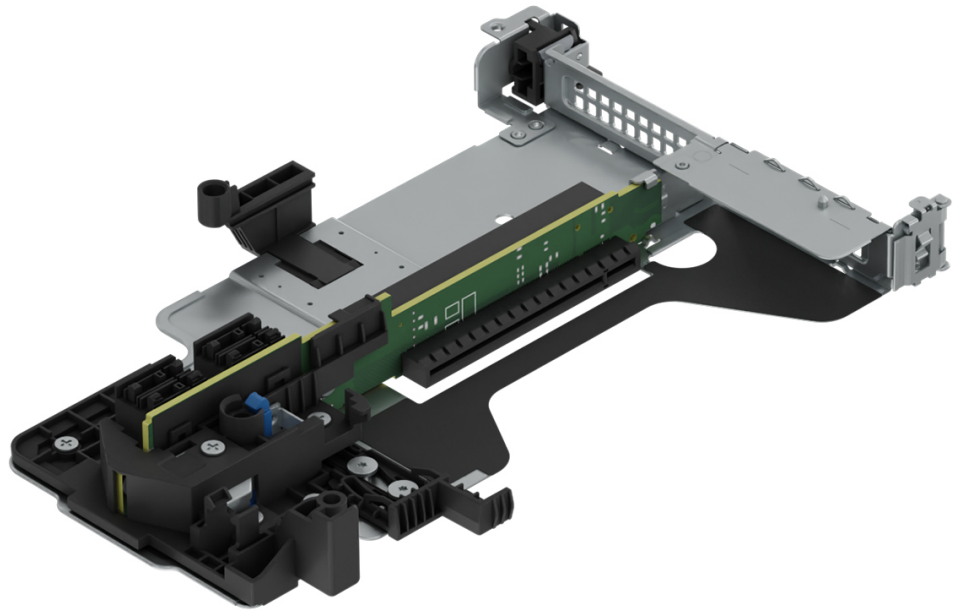

Figure 17. Riser R2A

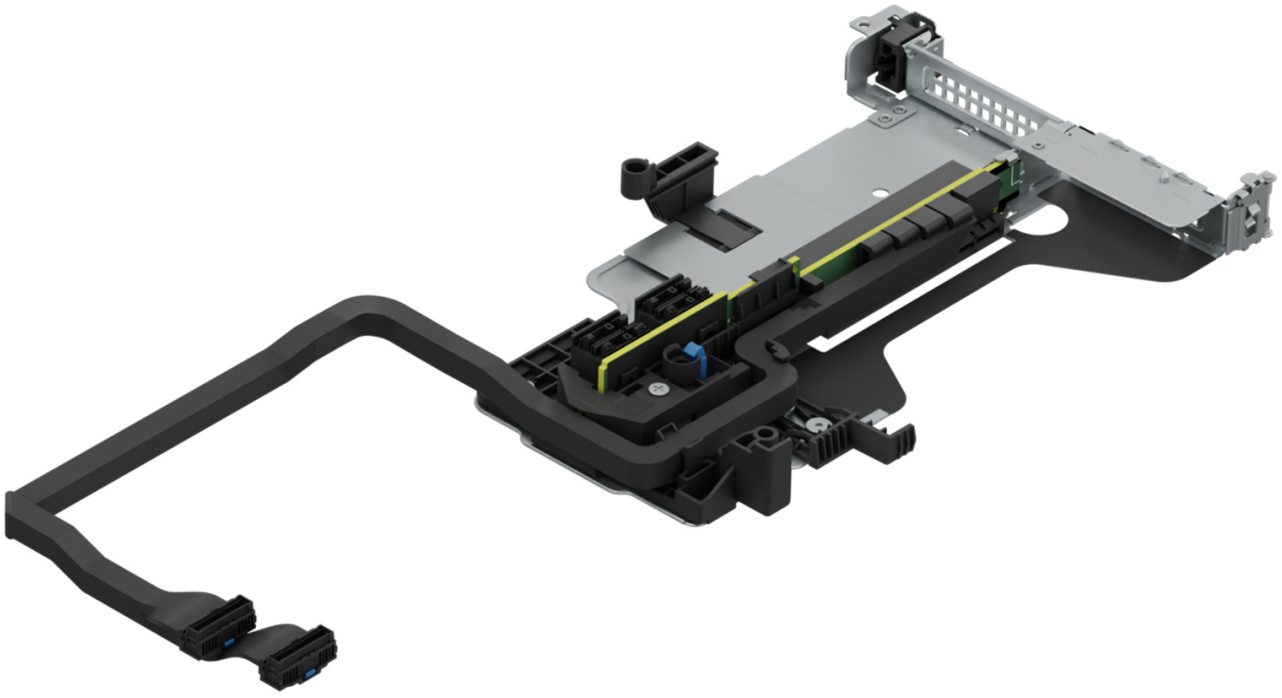

Figure 18. Riser R2T

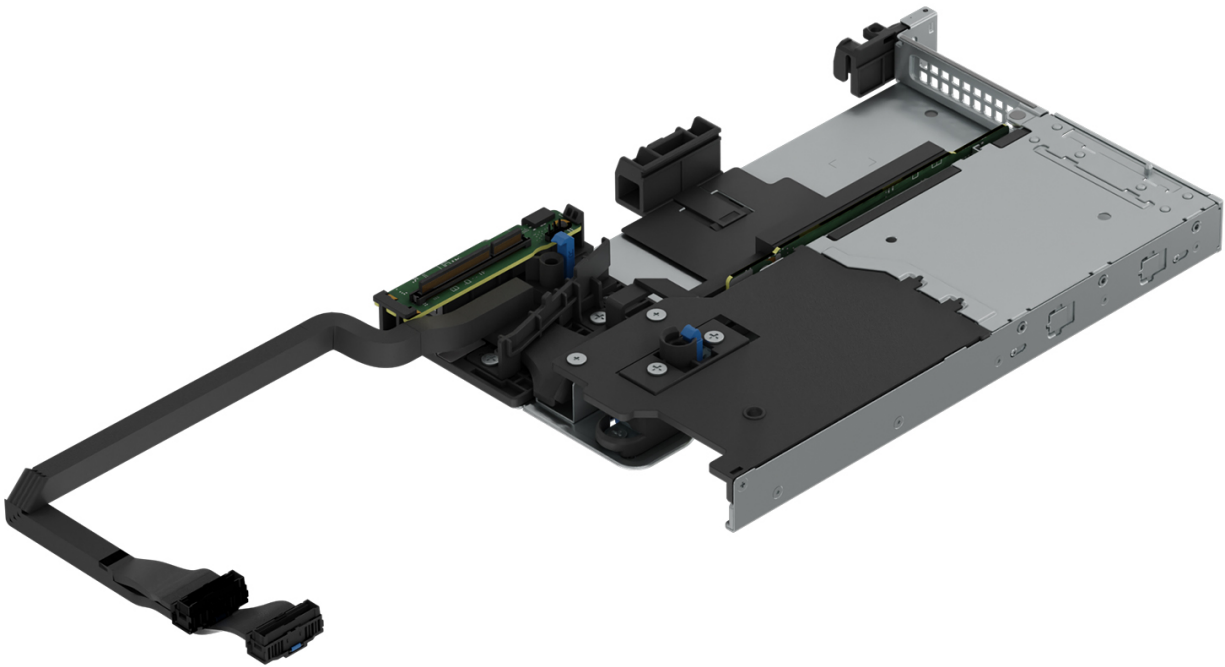

Figure 19. Riser R2U

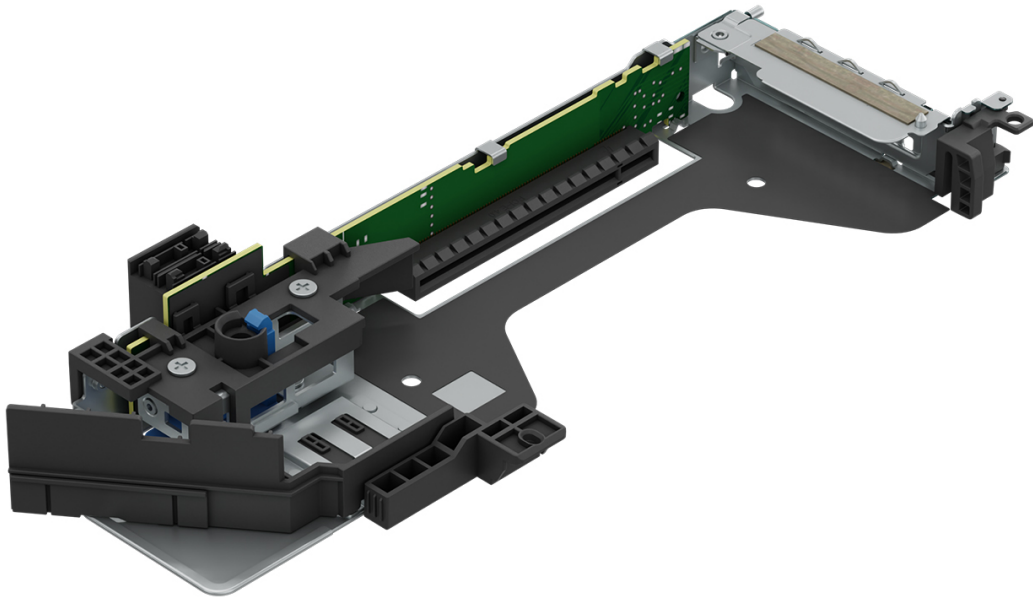

Figure 20. Riser R3A

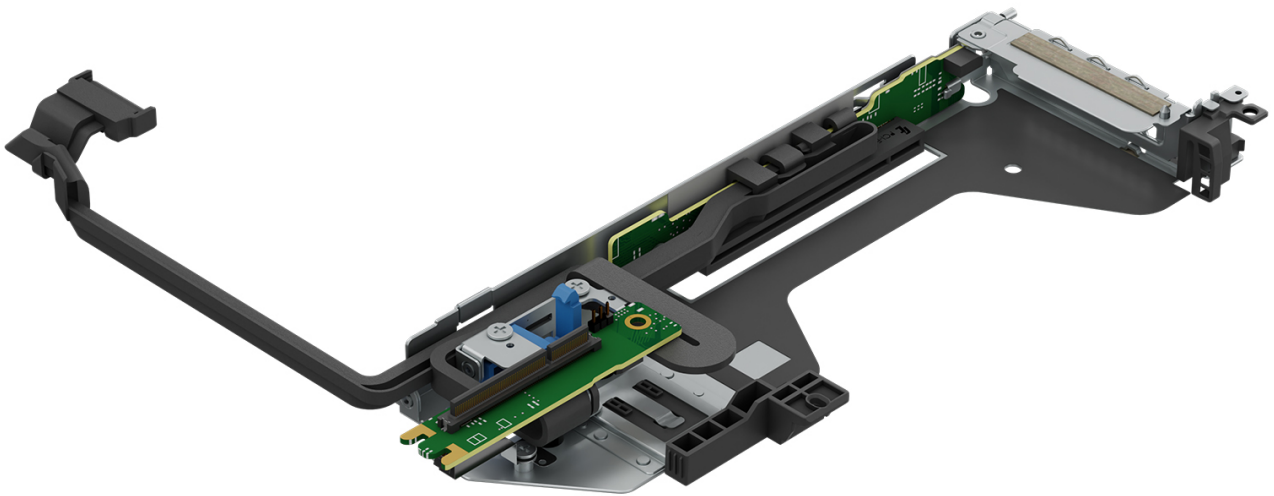

Figure 21. Riser R3P

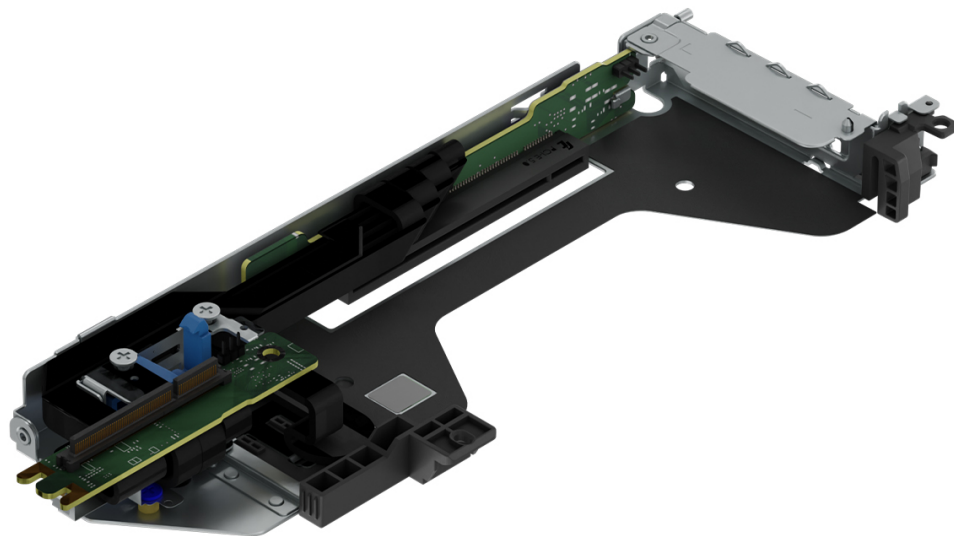

Figure 22. Riser R3S

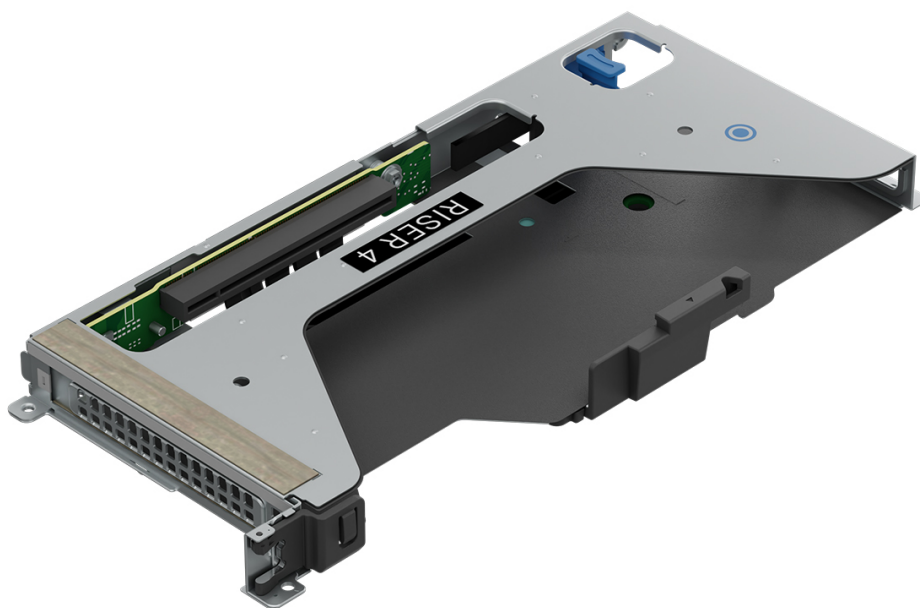

Figure 23. Riser R4P

Table 11. PCIe Riser Configs

Config No.	RSR Configuration	# of CPUs	PERC type supported	Rear Storage Possible
0	NO RSR	1	Front PERC	No
1	R2A + R3A	1	Front PERC	Yes

Table 11. PCIe Riser Configs (continued)

Config No.	RSR Configuration	# of CPUs	PERC type supported	Rear Storage Possible
2	R2T + R3P	1	Front PERC	Yes
3	R1Q + R4p	1	Front PERC	No
4	R2T	1	Front PERC	Yes
5	R3P	1	Front PERC	Yes
6	R2A	1	Front PERC	No
7	R2U + R3S	1	Front PERC	Yes
8	R2T + R3A	1	Front PERC	Yes

Power, thermal, and acoustics

PowerEdge servers have an extensive collection of sensors that automatically track thermal activity, which helps regulate temperature thereby reducing server noise and power consumption. The table below lists the tools and technologies Dell offers to lower power consumption and increase energy efficiency.

Topics:

- [Power](#)
- [Thermal](#)
- [Acoustics](#)

Power

Table 12. Power tools and technologies

Feature	Description
Power Supply Units(PSU) portfolio	Dell's PSU portfolio includes intelligent features such as dynamically optimizing efficiency while maintaining availability and redundancy. Find additional information in the Power supply units section.
Tools for right sizing	Enterprise Infrastructure Planning Tool (EIPT) is a tool that can help you determine the most efficient configuration possible. With Dell's EIPT, you can calculate the power consumption of your hardware, power infrastructure, and storage at a given workload. Learn more at Enterprise Infrastructure Planning Tool .
Industry Compliance	Dell's servers are compliant with all relevant industry certifications and guide lines, including 80 PLUS, Climate Savers and ENERGY STAR.
Power monitoring accuracy	PSU power monitoring improvements include: <ul style="list-style-type: none"> • Dell's power monitoring accuracy is currently 1%, whereas the industry standard is 5%. • More accurate reporting of power • Better performance under a power cap
Power capping	Use Dell's systems management to set the power cap limit for your systems to limit the output of a PSU and reduce system power consumption. Dell is the first hardware vendor to leverage AMD's GUARDMI for circuit-breaker fast capping.
Systems Management	iDRAC Enterprise and Datacenter provides server-level management that monitors, reports and controls power consumption at the processor, memory and system level. Dell OpenManage Power Center delivers group power management at the rack, row, and data center level for servers, power distribution units, and uninterruptible power supplies.
Active power management	AMD's GUARDMI is an embedded technology that provides individual server-level power reporting and power limiting functionality. Dell offers a complete power management solution comprised of AMD's GUARDMI accessed through Dell iDRAC9 Datacenter and OpenManage Power Center that allows policy-based management of power and thermal at the individual server, rack, and data center level. Hot spare reduces power consumption of redundant power supplies. Thermal control off a speed optimizes the thermal settings for your environment to reduce fan consumption and lower system power consumption. Idle power enables Dell servers to run as efficiently when idle as when at full workload.
Fresh Air cooling	See ASHRAE A3/A4 Thermal Restriction.

Table 12. Power tools and technologies (continued)

Feature	Description
Rack infrastructure	<p>Dell offers some of the industry's highest-efficiency power infrastructure solutions, including:</p> <ul style="list-style-type: none"> • Power distribution units (PDUs) • Uninterruptible power supplies (UPSs) • Energy Smart containment rack enclosures <p>Find additional information at: Data Center Power and Cooling Solutions.</p>

Power Supply Units

Energy Smart power supplies have intelligent features, such as the ability to dynamically optimize efficiency while maintaining availability and redundancy. Also featured are enhanced power-consumption reduction technologies, such as high-efficiency power conversion and advanced thermal-management techniques, and embedded power-management features, including high-accuracy power monitoring. The table below shows the power supply unit options that are available for the R6615.

Table 13. Power Supply Unit Options

Wattage	Frequency	Voltage/Current	Class	Heat dissipation
700 W mixed mode HLAC	50/60Hz	200-240 V AC/4.1 A	Titanium	2625 BTU/hr
	800 W mixed mode	240 V DC/3.4 A	N/A	2625 BTU/hr
800 W mixed mode	50/60Hz	100–240 V AC/9.2-4.7 A	Platinum	3000 BTU/hr
	N/A	240 V DC/3.8 A	N/A	3000 BTU/hr
1100 W mixed mode	50/60 Hz	100–240 V AC/12-6.3 A	Titanium	4100 BTU/hr
	N/A	240 V DC/5.2 A	N/A	4100 BTU/hr
1100 W -48 VDC	N/A	- (48—60) V DC/27A	N/A	4265 BTU/hr
1400 W mixed mode	50/60 Hz	100–240 V AC/12-8 A	Platinum	5250 BTU/hr
	N/A	240 V DC/6.6 A	N/A	5250 BTU/hr
1400 W mixed mode	50/60 Hz	100–240 V AC/12-8 A	Titanium	5250 BTU/hr
	N/A	240 V DC/6.6 A	N/A	5250 BTU/hr
1400 W mixed mode 277 Vac and HVDC	50/60 Hz	277 V AC/5.8 A	Titanium	5250 BTU/hr
	N/A	336 V DC/5.17 A	N/A	5250 BTU/hr
1800 W mixed mode HLAC	50/60 Hz	200-240 V AC/10 A	Titanium	6750 BTU/hr
	N/A	240 V DC/8.2 A	N/A	6750 BTU/hr

NOTE: If a system with AC 1400 W or 1100 W PSUs operates at low line 100-120 Vac, and then the power rating per PSU is degraded to 1050 W.

NOTE: Heat dissipation is calculated using the PSU wattage rating.

NOTE:

- HLAC stands for High-Line AC, with a range of 200 - 240 V AC.
- HVDC stands for High-Voltage DC, with 336 V DC.



Figure 24. PSU power cables

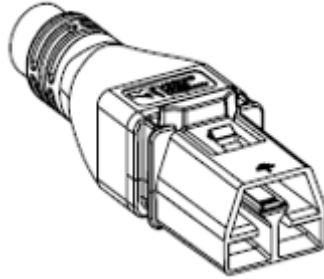

Figure 25. APP 2006G1 power cable

Table 14. PSU power cords

Form factor	Output	Power cable
Redundant 60 mm	700 W mixed mode HLAC	C13
	800 W mixed mode	C13
	1100 W mixed mode	C13
	1400 W mixed mode	C13
	1400 W mixed mode 277 Vac and HVDC	APP 2006G1
	1800 W mixed mode HLAC	C15

NOTE: C13 power cord combined with C14 to C15 jumper power cord can be used to adapt 1800 W PSU.

Thermal

PowerEdge servers have an extensive collection of sensors that automatically track thermal activity, which helps regulate temperature thereby reducing server noise and power consumption.

Thermal design

Thermal management of the platform helps deliver high performance with the right amount of cooling to components, while maintaining the lowest fan speeds possible. This is done across a wide range of ambient temperatures from 10°C to 35°C (50°F to 95°F) and to extended ambient temperature ranges.

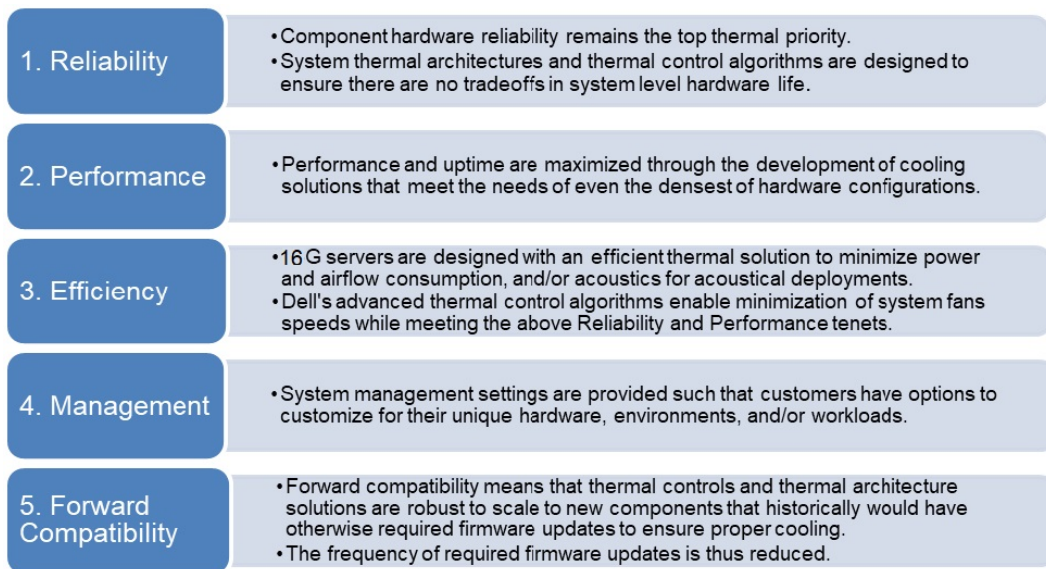

Figure 26. Thermal design characteristics

The thermal design of the PowerEdge R6615 reflects the following:

- Optimized thermal design: The system layout is architected for optimum thermal design.
- System component placement and layout are designed to provide maximum airflow coverage to critical components with minimum expense of fan power.
- Comprehensive thermal management: The thermal control system regulates the fan speed based on several different responses from all system-component temperature sensors, as well as inventory for system configurations. Temperature monitoring includes components such as processors, DIMMs, chipset, the inlet air ambient, hard disk drives, and OCP.
- Open and closed loop thermal fan speed control: Open loop thermal control uses system configuration to determine fan speed based on inlet air ambient temperature. Closed loop thermal control method uses feedback temperatures to dynamically determine proper fan speeds.
- User-configurable settings: With the understanding and realization that every customer has unique set of circumstances or expectations from the system, in this generation of servers, we have introduced limited user- configurable settings residing in the iDRAC BIOS setup screen. For more information, see the Dell PowerEdge R6615 Installation and Service Manual at [PowerEdge Manuals](#) and “Advanced Thermal Control: Optimizing across Environments and Power Goals” on Dell.com.
- Cooling redundancy: The R6615 allows N+1 fan redundancy, allowing continuous operation with one fan failure in the system.
- Environmental Specifications: The optimized thermal management makes the R6615 reliable under a wide range of operating environments.

Acoustics

Acoustical performance

Dell PowerEdge R6615 is a rack-mount server appropriate for attended data center environment. However, lower acoustical output is attainable with proper hardware or software configurations.

Table 15. Acoustical Configurations of R6615

Configuration	Quietest Low End	Entry	Volume - 1 (HPC)	Feature Rich
CPU Type	AMD Genoa	AMD Genoa	AMD Genoa	AMD Genoa
CPU TDP	200 W / 24°C	200 W / 24°C	200 W / 24°C	320 W / 48°C
CPU Quantity	1	1	1	1
Memory Type	16 GB DDR5	16 GB DDR5	64 GB DDR5	128 GB DDR5
DIMM Quantity	6	6	12	24

Table 15. Acoustical Configurations of R6615 (continued)

Configuration	Quietest Low End	Entry	Volume - 1 (HPC)	Feature Rich
Backplane Type	4 x 3.5 inches	4 x 3.5 inches	10 x 2.5 inches	10 x 2.5 inches
HDD Type	3.5 inches SATA 2 TB	3.5 inches SATA 2 TB	2.5 inches NVMe SSD	Intel P4500 2TB NVMe SSD
HDD Quantity	2	2	10	Feature Rich
PSU Type	800 W	800 W	1400 W	1400 W
PSU Quantity	2	2	2	2
PCI 1	N/A	N/A	Dual Port 25 GbE	N/A
PCI 2	N/A	N/A	Dual Port 25 GbE	N/A
Front PERC	PERC H355	PERC H355	PERC H355	No PERC
OCP	Dual Port 10 GbE	Dual Port 10 GbE	Dual Port 25 GbE	Dual Port 200 GbE
M.2	No	No	BOSS-N1	BOSS-N1

Table 16. Acoustical experience of R6615 configurations

Configuration	Quietest Low End	Entry	Volume - 1 (HPC)	Feature Rich	
Acoustical Performance: Idle/ Operating @ 25°C Ambient					
L _{wA,m} (B)	Idle ⁽⁴⁾	5.2	5.2	5.5	6.0
	Operating/Customer usage operating ⁽⁵⁾⁽⁶⁾	5.2	5.2	5.5	6.0
K _v (B)	Idle ⁽⁴⁾	0.4	0.4	0.4	0.4
	Operating/Customer usage operating ⁽⁵⁾⁽⁶⁾	0.4	0.4	0.4	0.4
L _{pA,m} (dB)	Idle ⁽⁴⁾	35	35	39	43
	Operating/Customer usage operating ⁽⁵⁾⁽⁶⁾	35	35	39	43
Prominent tones ⁽³⁾		No prominent tones in Idle and Operating			
Acoustical Performance: Idle @ 28°C Ambient					
L _{wA,m} ⁽¹⁾ (B)	5.4	5.4	5.9	6.2	
K _v (B)	0.4	0.4	0.4	0.4	
L _{pA,m} ⁽²⁾ (dB)	38	38	43	46	
Acoustical Performance: Max. loading @ 35°C Ambient					
L _{wA,m} ⁽¹⁾ (B)	7.8	7.8	8.0	8.6	
K _v (B)	0.4	0.4	0.4	0.4	
L _{pA,m} ⁽²⁾ (dB)	63	63	64	70	

⁽¹⁾L_{wA,m}: The declared mean A-weighted sound power level (L_{wA}) is calculated per section 5.2 of ISO 9296 (2017) with data collected using the methods that are described in ISO 7779 (2010). Engineering data presented here may not be fully compliant with the ISO 7779 declaration requirement.

⁽²⁾L_{pA,m}: The declared mean that A-weighted emission sound pressure level is at the bystander position per section 5.3 of ISO 9296 (2017) and measured using methods that are described in ISO 7779 (2010). The system is placed in a 24U rack enclosure,

75 cm above a reflective floor. Engineering data presented here may not be fully compliant with the ISO 7779 declaration requirement.

⁽³⁾Prominent tones: Criteria of Annex D of ECMA-74 and the Prominence Ratio method of ECMA-418 are followed to determine if discrete tones are prominent and to report them, if so.

⁽⁴⁾Idle mode: The steady-state condition in which the server is energized but not operating any intended function.

⁽⁵⁾Operating mode: The maximum of the steady state acoustical output at 50% of CPU TDP or active storage drives for the respective sections of Annex C of ECMA-74.

⁽⁶⁾ Customer Usage Operating mode: The operating mode is represented by the maximum of the steady state acoustical output at 25%~30% of CPU TDP, 2.5%~10% IOPs load, and >80% GPU load as the components showed in the above configurations.

Rack, rails, and cable management

Topics:

- [Rails and cable management information](#)

Rails and cable management information

The rail offerings for the PowerEdge R6615 consist of two general types: sliding and static. The cable management offerings consist of an optional cable management arm (CMA) and an optional strain relief bar (SRB).

See the [Dell Enterprise Systems Rail Sizing and Rack Compatibility Matrix](#) for information regarding:

- Specific details about rail types.
- Rail adjustability ranges for various rack mounting flange types
- Rail depth with and without cable management accessories
- Rack types that are supported for various rack mounting flange types

Key factors governing proper rail selection include the following:

- Spacing between the front and rear mounting flanges of the rack
- Type and location of any equipment that is mounted in the back of the rack such as power distribution units (PDUs)
- Overall depth of the rack

Sliding rails features summary

The sliding rails allow the system to be fully extended out of the rack for service. There are two types of sliding rails available, ReadyRails II sliding rails and Stab-in/Drop-in sliding rails. The sliding rails are available with or without the optional cable management arm (CMA) or strain relief bar (SRB).

A15 ReadyRails sliding rails for 4-post racks

- Supports drop-in installation of the chassis to the rails.
- Support for tool-less installation in 19" EIA-310-E compliant square or un-threaded round hole 4-post racks including all generations of the Dell racks.
- Support for tooled installation in 19" EIA-310-E compliant threaded hole 4-post racks.
- Support full extension of the system out of the rack to allow serviceability of key internal components.
- Support for optional strain relief bar (SRB).
- Support for optional cable management arm (CMA).

NOTE: For situations where CMA support is not required, the outer CMA mounting brackets can be uninstalled from the sliding rails. This reduces the overall length of the rails and eliminates the potential interferences with rear mounted PDUs or the rear rack door.

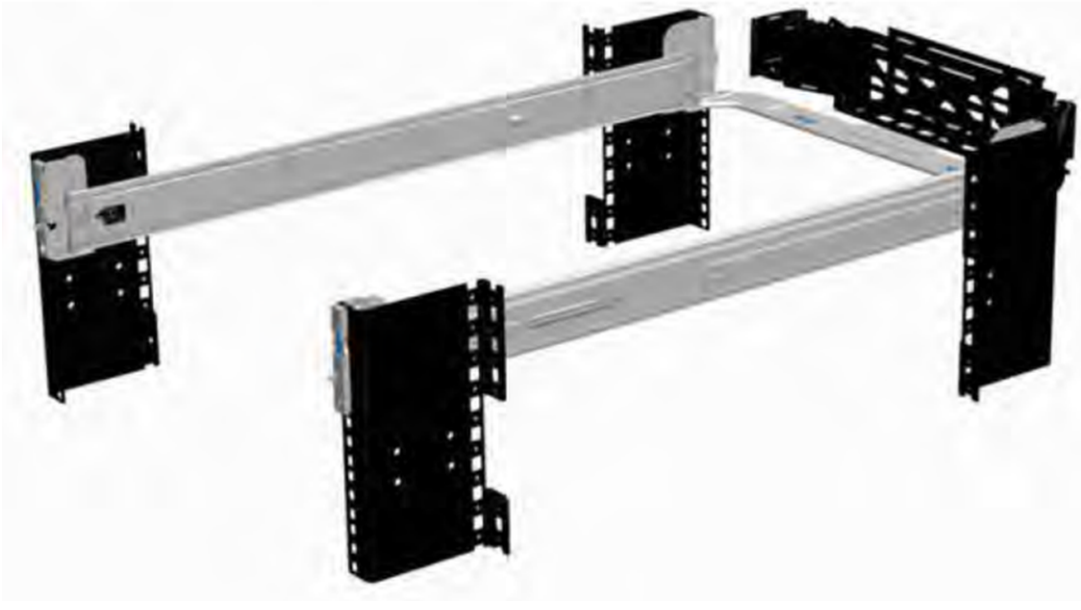

Figure 27. Sliding rails with optional CMA

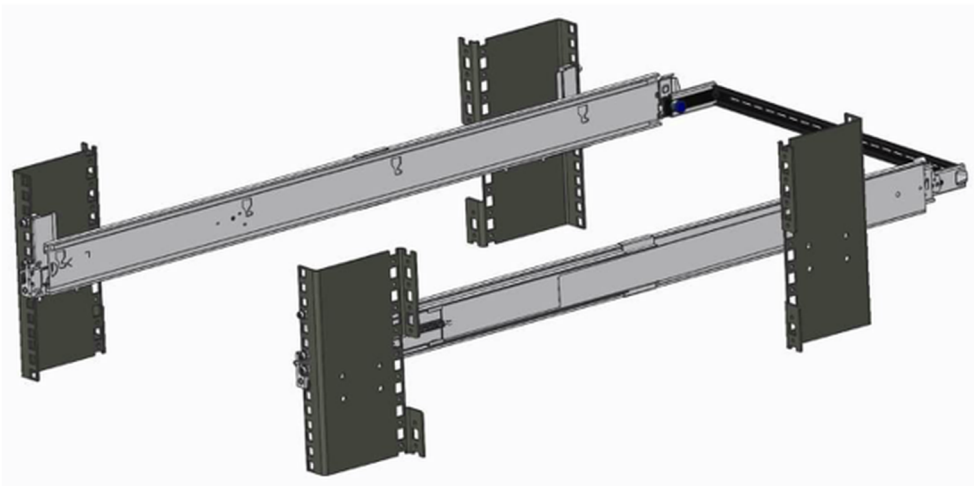

Figure 28. Sliding rails with optional SRB

A16 Stab-in/Drop-in sliding rails for 4-post racks

- Supports drop-in or stab-in installation of the chassis to the rails.
- Support for tool-less installation in 19" EIA-310-E compliant square, un-threaded round hole racks including all generations of the Dell racks. Also supports tool-less installation in threaded round hole 4-post racks.
- Support for tool-less installation in Dell Titan or Titan-D racks
- Support full extension of the system out of the rack to allow serviceability of key internal components.
- Support for optional cable management arm (CMA).
- Support for optional strain relief bar (SRB).

i NOTE: For situations where CMA support is not required, the outer CMA mounting brackets can be uninstalled from the sliding rails. This reduces the overall length of the rails and eliminates the potential interferences with rear mounted PDUs or the rear rack door.

A14 static rails summary

The static rails offer a greater adjustability range and a smaller overall mounting footprint than the sliding rails because of their reduced complexity and lack of need for CMA support. The static rails support a wider variety of racks than the sliding rails. However, they do not support serviceability in the rack and are thus not compatible with the CMA. The static rails are also not compatible with SRB.

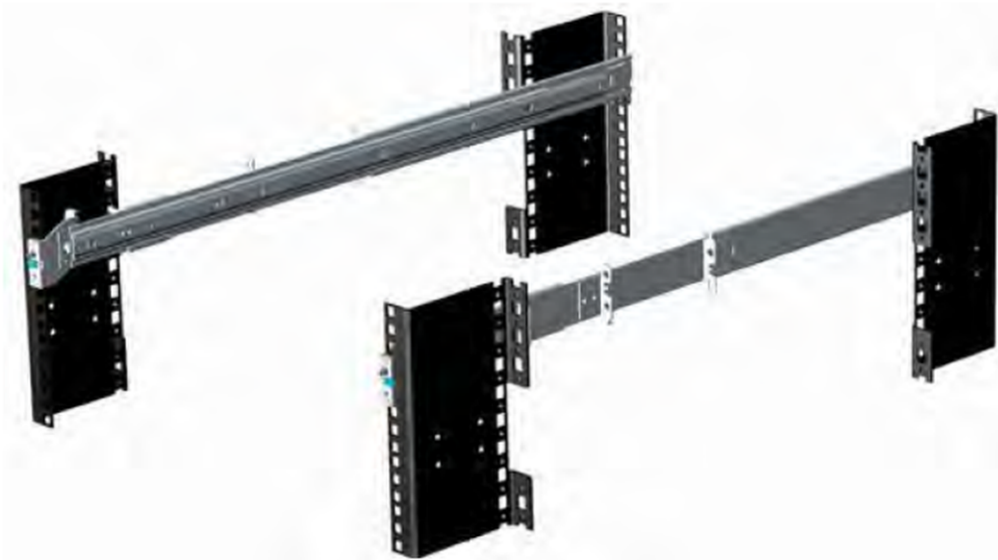

Figure 29. Static rails

Static rails features summary

Static rails for 4-post & 2-post racks:

- Supports stab-in installation of the chassis to the rails.
- Support tool-less installation in 19" EIA-310-E compliant square or un-threaded round hole 4-post racks including all generations of Dell racks.
- Support tool-less installation in 19" EIA-310-E compliant threaded hole 4-post and 2-post racks.
- Support for tool-less installation in Dell Titan or Titan-D rack.

NOTE:

- Screws are not included with the static rail kit since racks are offered with various thread types. The screws are provided for mounting static rails in racks with threaded mounting flanges.
- Screw head diameter should be 10 mm or less.

2-Post racks installation

If installing to 2-Post (Telco) racks, the ReadyRails static rails (A14) must be used. Sliding rails support mounting in 4-post racks only.



Figure 30. Static rails in 2-post center mount configuration

Installation in the Dell Titan or Titan-D racks

For tool-less installation in Titan or Titan-D racks, the Stab-in/Drop-in Sliding rails (A16) must be used. This rail collapses down sufficiently to fit in the rack with mounting flanges that are spaced about 24 inches apart from front to back. The Stab-in/Drop-in Sliding rail allows bezels of the servers and storage systems to be aligned when installed in these racks. For tooled installation, Stab-in Static rails (A14) must be used for bezel alignment with Storage systems.

Cable management arm (CMA)

The optional cable management arm (CMA) organizes and secures the cords and cables exiting the back of the systems. It unfolds to allow the systems to extend out of the rack without having to detach the cables. Some key features of the CMA include:

- Large U-shaped baskets to support dense cable loads.
- Open vent pattern for optimal airflow.
- Ability to mount on either side by swinging the spring-loaded brackets from one side to the other.
- Utilizes hook-and-loop straps rather than plastic tie wraps to eliminate the risk of cable damage during cycling.
- Includes a low-profile fixed tray to both support and retain the CMA in its fully closed position.
- Both the CMA and the tray mount without the use of tools by simple and intuitive snap-in designs.

NOTE: CMA is not supported in Direct Liquid Cooling configuration.

The CMA can be mounted to either side of the sliding rails without the use of tools or the need for conversion. For systems with one power supply unit (PSU), it is recommended to mount on the side opposite to that of the power supply to allow easier access to it and the rear drives (if applicable) for service or replacement.

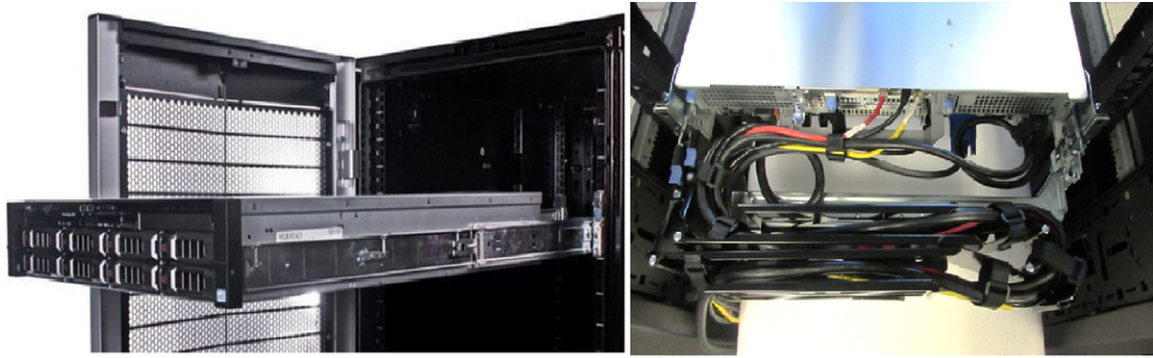

Figure 31. Sliding rails with CMA cabling

Strain Relief Bar (SRB)

The optional strain relief bar (SRB) for the PowerEdge R6615 organizes and supports cable connections at the rear end of the server to avoid damage from bending.

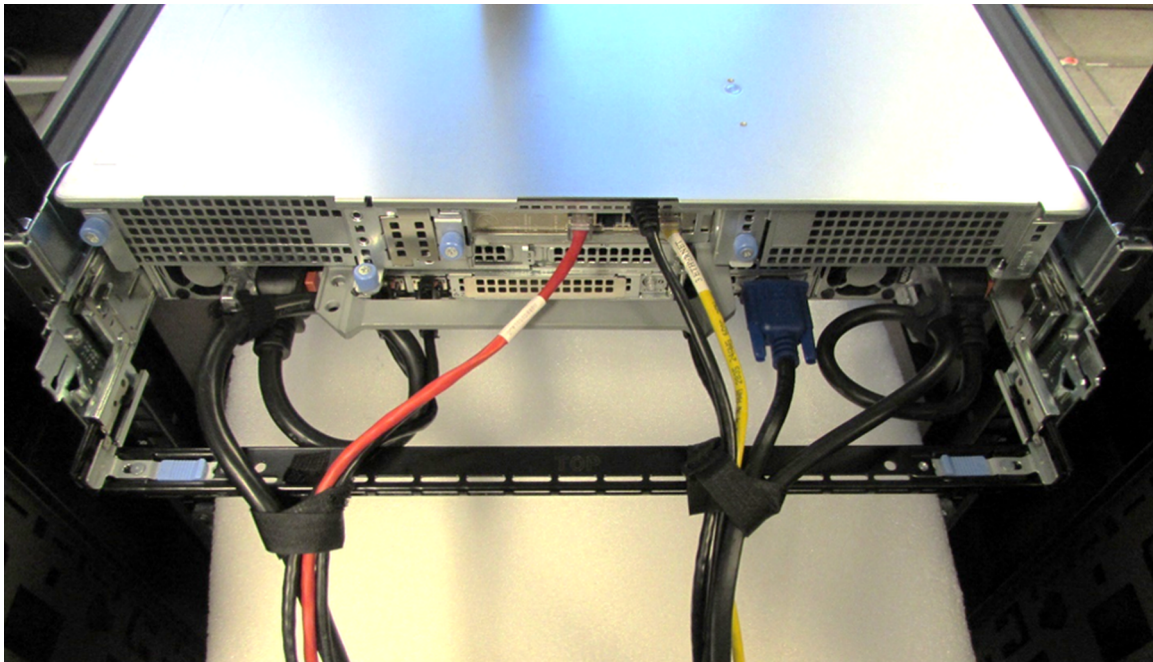

Figure 32. Cabled strain relief bar

- Tool-less attachment to the rails
- Two depth positions to accommodate various cable loads and rack depths
- Supports cable loads and controls stresses on server connectors
- Cables can be separated into discrete purpose-specific bundles

Rack Installation

Drop-in design means that the system is installed vertically into the rails by inserting the standoffs on the sides of the system into the J-slots in the inner rail members with the rails in the fully extended position. The recommended method of installation is to first insert the rear standoffs on the system into the rear J-slots on the rails to free up a hand and then rotate the system down into the remaining J-slots while using the free hand to hold the rail against the side of the system.

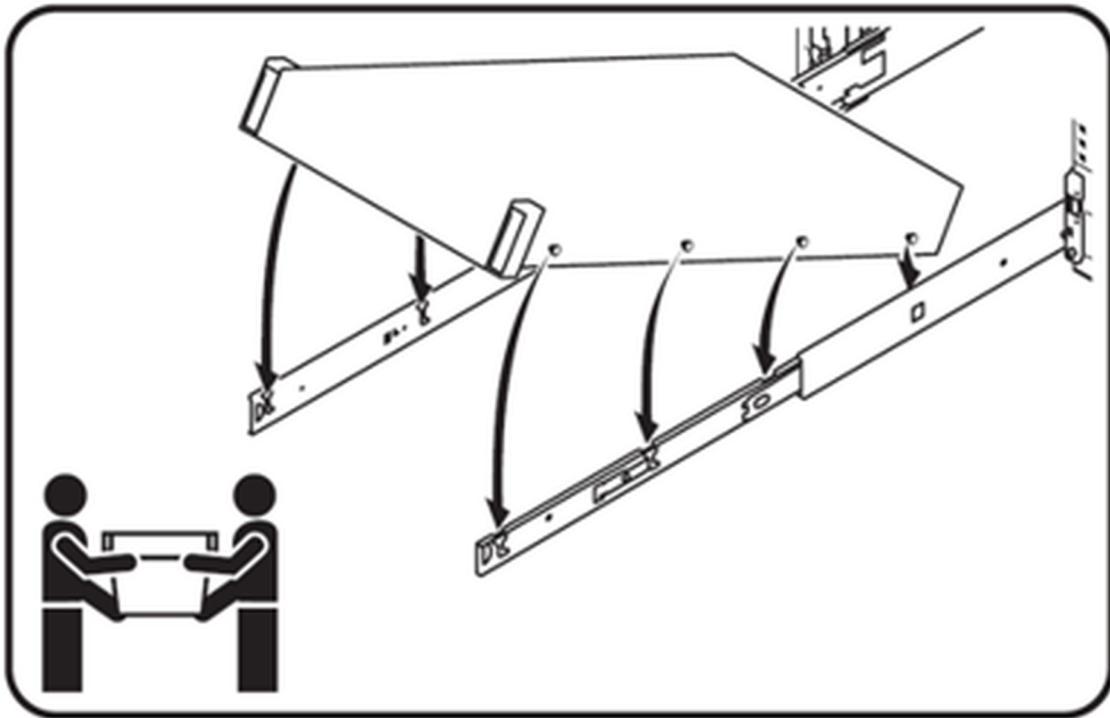

Figure 33. Installing the system in Drop-in sliding rails

Stab-in design means that the inner (chassis) rail members must first be attached to the sides of the system and then inserted into the outer (cabinet) members installed in the rack. For a 2U systems, this is a two person lift.

Installing system into the rack (option A: Drop-In)

1. Pull the inner rails out of the rack until they lock into place.

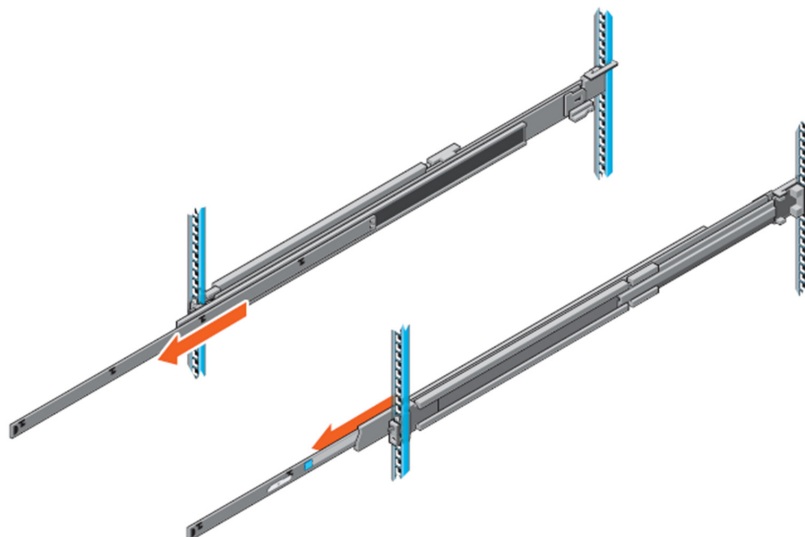

Figure 34. Pull out inner rail

2. Locate the rear rail standoff on each side of the system and lower them into the rear J-slots on the slide assemblies.
3. Rotate the system downward until all the rail standoffs are seated in the J-slots.

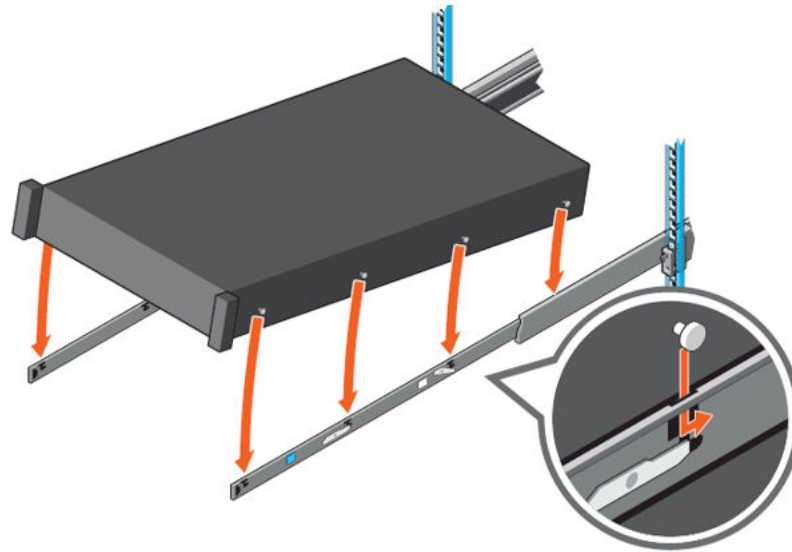

Figure 35. Rail standoffs seated in J-slots

4. Push the system inward until the lock levers click into place.
5. Pull the blue side release lock tabs forward or backward on both rails and slide the system into the rack until the system is in the rack.

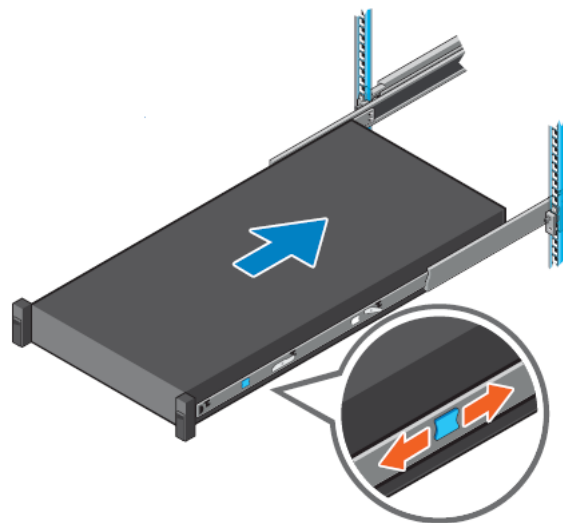

Figure 36. Slide system into the rack

Installing the system into the rack (option B: Stab-In)

1. Pull the intermediate rails out of the rack until they lock into place.
2. Release the inner rail lock by pulling forward on the white tabs and sliding the inner rail out of the intermediate rails.

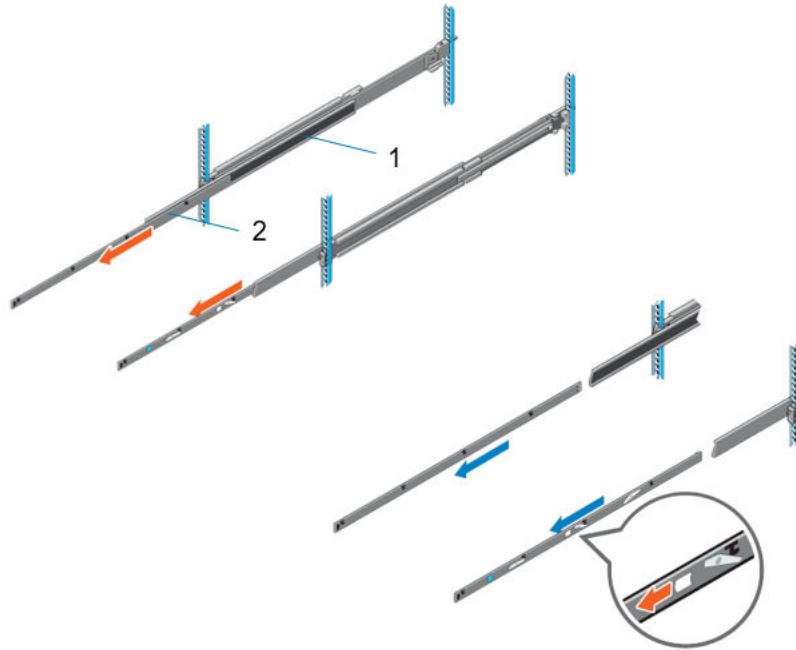

Figure 37. Pull out the intermediate rail

Table 17. Rail component label

Number	Component
1	Intermediate rail
2	Inner rail

3. Attach the inner rails to the sides of the system by aligning the J-slots on the rail with the standoffs on the system and sliding forward on the system until they lock into place.

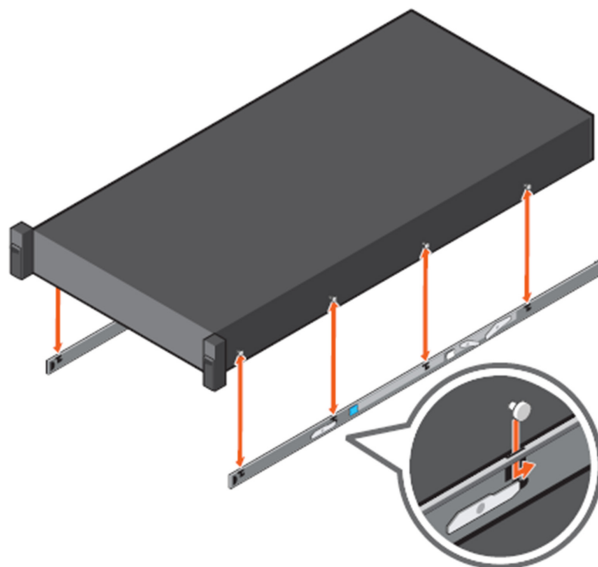

Figure 38. Attach the inner rails to the system

4. With the intermediate rails extended, install the system into the extended rails.

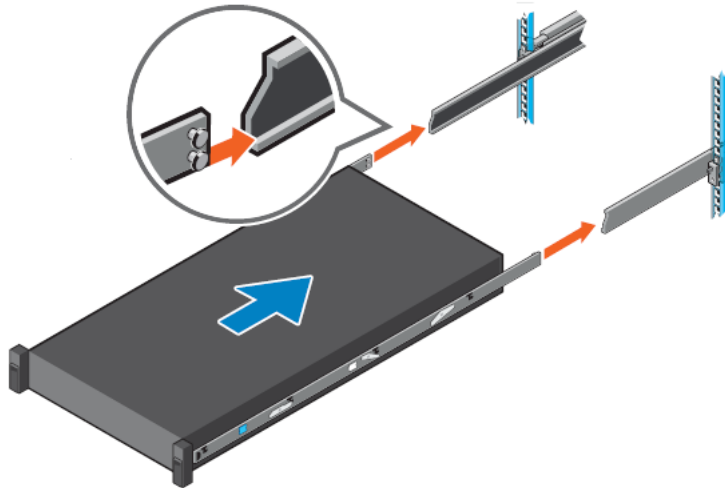

Figure 39. Install system into the extended rails

5. Pull blue slide release lock tabs forward or backward on both rails, and slide the system into the rack.

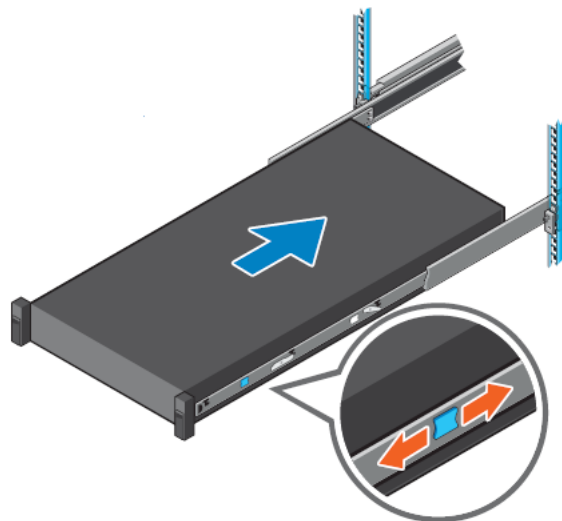

Figure 40. Slide system into the rack

Operating Systems and Virtualization

Topics:

- [Supported Operating Systems](#)

Supported Operating Systems

The PowerEdge system supports the following operating system:

- Canonical Ubuntu Server LTS
- Microsoft Windows Server with Hyper-V
- Red Hat Enterprise Linux
- SUSE Linux Enterprise Server
- VMware vSAN/ESXi
- Citrix XenServer

Links to specific OS versions and editions, certification matrices, Hardware Compatibility Lists (HCL) portal, and Hypervisor support are available at [Dell Enterprise Operating Systems](#).

Dell Systems Management

Dell delivers management solutions that help IT administrators effectively deploy, update, monitor, and manage IT assets. Dell solutions and tools enable you to quickly respond to problems by helping them to manage Dell servers efficiently; in physical, virtual, local, and remote environments; all without the need to install an agent in the operating system.

The OpenManage portfolio includes:

- Innovative embedded management tools - integrated Dell Remote Access Controller (iDRAC)
- Consoles - OpenManage Enterprise
- Extensible with plug-ins - OpenManage Power Manager
- Update tools - Repository Manager

Dell has developed comprehensive systems management solutions that are based on open standards and has integrated with management consoles from partners such as Microsoft and VMware, allowing advanced management of Dell servers. Dell management capabilities extend to offerings from the industry's top systems management vendors and frameworks such as Ansible, Splunk, and ServiceNow. OpenManage tools automate the full span of server life cycle management activities along with powerful RESTful APIs to script or integrate with your choice of frameworks.

For more information about the entire OpenManage portfolio, see:

- The latest [Dell Systems Management Overview Guide](#).

Topics:

- [Integrated Dell Remote Access Controller \(iDRAC\)](#)
- [Systems Management software support matrix](#)

Integrated Dell Remote Access Controller (iDRAC)

iDRAC9 delivers advanced, agent-free, local and remote server administration. Embedded in every PowerEdge server, iDRAC9 provides a secure means to automate a multitude of common management tasks. Because iDRAC is embedded within every PowerEdge server, there is no additional software to install; just plug in power and network cables, and iDRAC is ready to go. Even before installing an operating system (operating system) or hypervisor, IT administrators have a complete set of server management features at their fingertips.

With iDRAC9 in-place across the Dell PowerEdge portfolio, the same IT administration techniques and tools can be applied throughout. This consistent management platform allows easy scaling of PowerEdge servers as an organization's infrastructure grows. Customers can use the iDRAC RESTful API for the latest in scalable administration methods of PowerEdge servers. With this API, iDRAC enables support for the Redfish standard and enhances it with Dell extensions to optimize at-scale management of PowerEdge servers. By having iDRAC at the core, the entire OpenManage portfolio of Systems Management tools allows every customer to tailor an effective, affordable solution for any size environment.

Zero Touch Provisioning (ZTP) is embedded in iDRAC. ZTP - Zero Touch Provisioning is Intelligent Automation Dell's agent-free management puts IT administrators in control. Once a PowerEdge server is connected to power and networking, that system can be monitored and fully managed, whether you're standing in front of the server or remotely over a network. In fact, with no need for software agents, an IT administrator can: • Monitor • Manage • Update • Troubleshoot and remediate Dell servers With features like zero-touch deployment and provisioning, iDRAC Group Manager, and System Lockdown, iDRAC9 is purpose-built to make server administration quick and easy. For those customers whose existing management platform utilizes in-band management, Dell does provide iDRAC Service Module, a lightweight service that can interact with both iDRAC9 and the host operating system to support legacy management platforms.

When ordered with DHCP enabled from the factory, PowerEdge servers can be automatically configured when they are initially powered up and connected to your network. This process uses profile-based configurations that ensure each server is configured per your specifications. This feature requires an iDRAC Enterprise license.

iDRAC9 offers following license tiers:

Table 18. iDRAC9 license tiers

License	Description
iDRAC9 Basic	<ul style="list-style-type: none"> • Available only on 100-500 series rack/tower • Basic instrumentation with iDRAC web UI • For cost conscious customers that see limited value in management
iDRAC9 Express	<ul style="list-style-type: none"> • Default on 600+ series rack/tower, modular, and XR series • Includes all features of Basic • Expanded remote management and server life-cycle features
iDRAC9 Enterprise	<ul style="list-style-type: none"> • Available as an upsell on all servers • Includes all features of Basic and Express. Includes key features such as virtual console, AD/LDAP support, and more • Remote presence features with advanced, Enterprise-class, management capabilities
iDRAC9 Datacenter	<ul style="list-style-type: none"> • Available as an upsell on all servers • Includes all features of Basic, Express, and Enterprise. Includes key features such as telemetry streaming, Thermal Manage, automated certificate management, and more • Extended remote insight into server details, focused on high end server options, granular power, and thermal management

For a full list of iDRAC features by license tier, see [Integrated Dell Remote Access Controller 9 User's Guide](#) at [Dell.com](#).

For more details on iDRAC9 including white papers and videos, see:

- [Support for Integrated Dell Remote Access Controller 9 \(iDRAC9\)](#) on the [Knowledge Base](#) page at [Dell.com](#)

Systems Management software support matrix

Table 19. Systems Management software support matrix

Categories	Features	PE mainstream
Embedded Management and In-band Services	iDRAC9 (Express, Enterprise, and Datacenter licenses)	Supported
	OpenManage Mobile	Supported
	OM Server Administrator (OMSA)	Supported
	iDRAC Service Module (iSM)	Supported
	Driver Pack	Supported
Change Management	Update Tools (Repository Manager, DSU, Catalogs)	Supported
	Server Update Utility	Supported
	Lifecycle Controller Driver Pack	Supported
	Bootable ISO	Supported
Console and Plug-ins	OpenManage Enterprise	Supported
	Power Manager Plug-in	Supported
	Update Manager Plug-in	Supported
	SupportAssist Plug-in	Supported
	CloudIQ	Supported
Integrations and connections	OM Integration with VMware Vcenter/vROps	Supported
	OM Integration with Microsoft System Center (OMIMSC)	Supported
	Integrations with Microsoft System Center and Windows Admin Center (WAC)	Supported

Table 19. Systems Management software support matrix (continued)

Categories	Features	PE mainstream
	ServiceNow	Supported
	Ansible	Supported
	Third-party Connectors (Nagios, Tivoli, Microfocus)	Supported
Security	Secure Enterprise Key Management	Supported
	Secure Component Verification	Supported
Standard operating system	Red Hat Enterprise Linux, SUSE, Windows Server 2019 or 2022, Ubuntu, CentOS	Supported (Tier-1)

Appendix A. Additional specifications

Topics:

- Chassis dimensions
- System weight
- NIC port specifications
- Video specifications
- USB ports specifications
- PSU rating
- Environmental specifications

Chassis dimensions

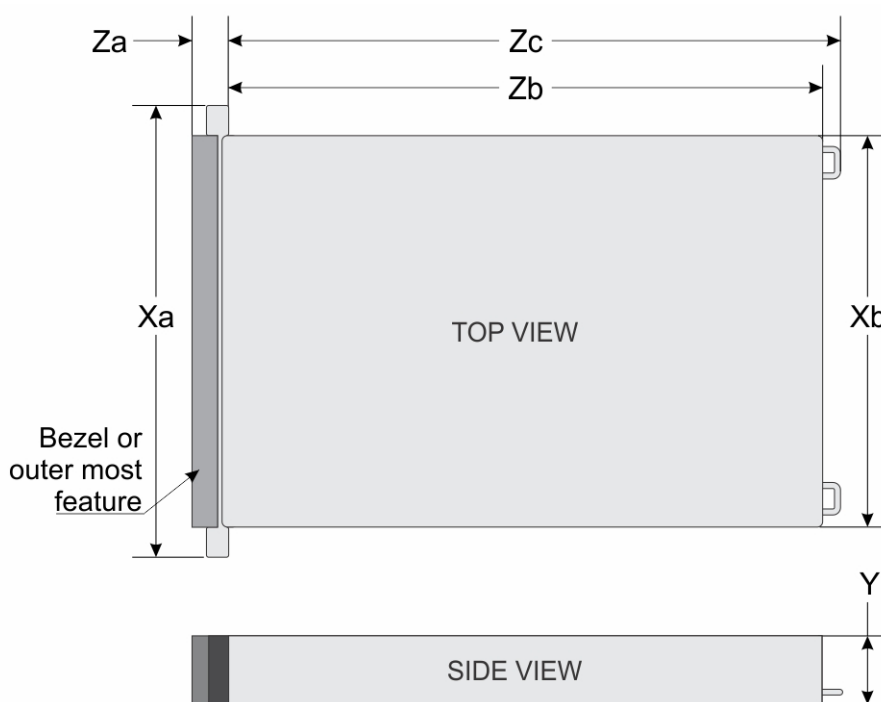

Figure 41. Chassis dimensions

Table 20. PowerEdge R6615 chassis dimensions

Drives	Xa	Xb	Y	Za with bezel	Za without bezel	Zb	Zc
0 drive	482.0 mm (18.97 inches)	434.0 mm (17.08 inches)	42.8 mm (1.685 inches)	35.84 mm (1.4 inches) With bezel	22.0 mm (0.87 inches) Without bezel	700.7 mm (27.58 inches) Ear to rear wall	736.29 mm (28.99 inches) Ear to PSU handle
4 drives, 8 drives, 10 drives	482.0 mm (18.97 inches)	434.0 mm (17.08 inches)	42.8 mm (1.685 inches)	35.84 mm (1.4 inches) With bezel	22.0 mm (0.87 inches) Without bezel	751.48 mm (29.59)	787.05 mm (30.99 inches) Ear

Table 20. PowerEdge R6615 chassis dimensions (continued)

Drives	Xa	Xb	Y	Za with bezel	Za without bezel	Zb	Zc
						inches) Ear to rear wall	to PSU handle

NOTE: Zb is the nominal rear wall external surface where the system board I/O connectors reside.

System weight

Table 21. PowerEdge R6615 system weight

System configuration	Maximum weight (with all drives/SSDs)
A server with fully populated drives	20.2 kg (44.53 lbs)
A server without drives and PSU installed	17.4 kg (38.36 lbs)

NIC port specifications

The PowerEdge R6615 system supports up to two 10/100/1000 Mbps Network Interface Controller (NIC) ports embedded on the LAN on Motherboard (LOM) and integrated on the Open Compute Project (OCP) cards.

Table 22. NIC port specification for the system

Feature	Specifications
LOM card (optional)	1 GB x 2
OCP card 3.0 (optional)	1 GbE x 4, 10 GbE x 2, 25 GbE x 2, 25 GbE x 4, 50 GbE x 2, 100 GbE x 2
Management Interface Card (MIC) to support Dell Data Processing Unit (DPU) card (optional)	25 GbE x 2, or 100 GbE x 2

NOTE: The system allows either LOM card or an OCP card or both to be installed in the system.

NOTE: On the system board, the supported OCP PCIe width is x8; when x16 PCIe width is installed, it is downgraded to x8.

NOTE: The system allows either LOM card or MIC card to be installed in the system.

Video specifications

The PowerEdge R6615 system supports integrated Matrox G200 graphics controller with 16 MB of video frame buffer.

Table 23. Video specifications for R6615

Resolution	Refresh rate (Hz)	Color depth (bits)
1024 x 768	60	8, 16, 32
1280 x 800	60	8, 16, 32
1280 x 1024	60	8, 16, 32
1360 x 768	60	8, 16, 32
1440 x 900	60	8, 16, 32
1600 x 900	60	8, 16, 32

Table 23. Video specifications for R6615 (continued)

Resolution	Refresh rate (Hz)	Color depth (bits)
1600 x 1200	60	8, 16, 32
1680 x 1050	60	8, 16, 32
1920 x 1080	60	8, 16, 32
1920 x 1200	60	8, 16, 32

USB ports specifications

Table 24. PowerEdge R6615 USB specifications

Front		Rear		Internal (optional)	
USB port type	No. of ports	USB port type	No. of ports	USB port type	No. of ports
USB 2.0-compliant port	One	USB 3.0-compliant port	One	Internal USB 3.0-compliant port	One
iDRAC Direct port (Micro-AB USB 2.0-compliant port)	One	USB 2.0-compliant ports	One		

NOTE: The micro USB 2.0 compliant port can only be used as an iDRAC Direct or a management port.



Figure 42. R6615 Front USB



Figure 43. R6615 Rear USB

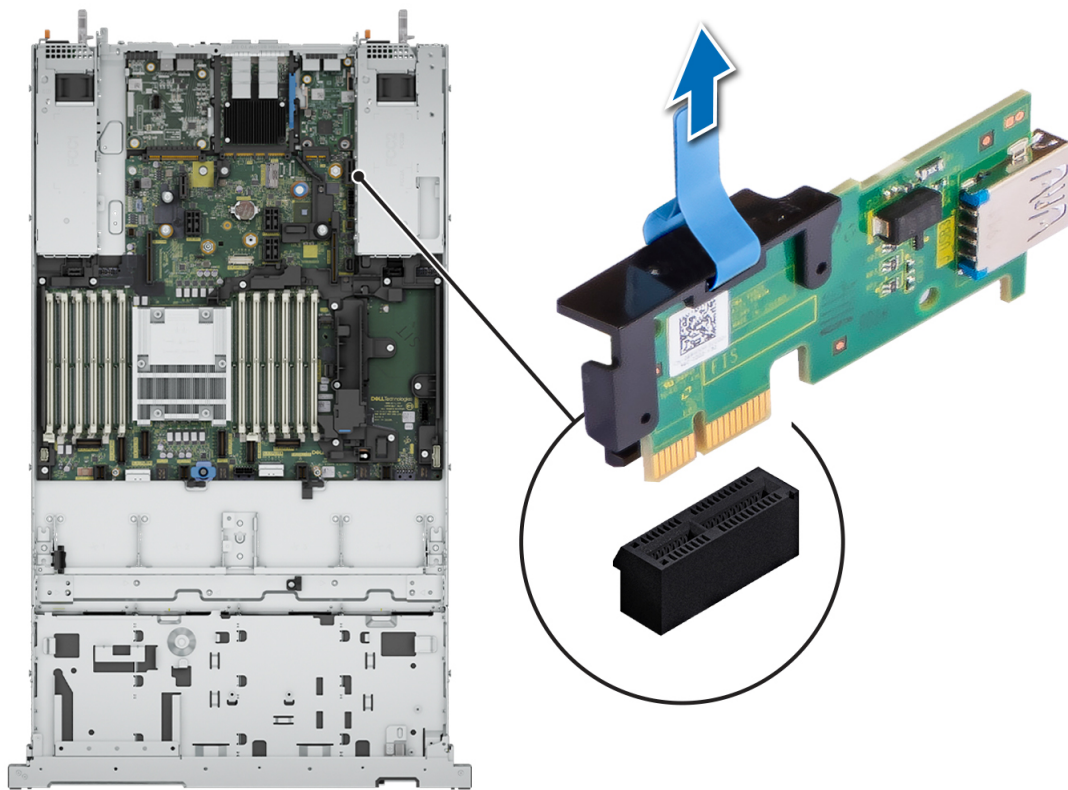

Figure 44. Internal USB Port

PSU rating

Below table lists the power capacity of the PSUs in high/low line operation mode.

Table 25. PSUs Highline and Lowline ratings

Features	700 W Titanium	800 W Platinum	1100 W Titanium	1100 W -48VDC	1400 W Platinum	1400 W Titanium	1800 W Platinum
Peak Power (Highline/-72 VDC)	1190 W	1360 W	1870 W	1870 W	2380 W	2380 W	3060 W
Highline /-72 VDC	700 W	800 W	1100 W	1100 W	1400 W	1400 W	1800 W
Peak Power (Lowline/-40 VDC)	N/A	1360 W	1785 W	N/A	1785 W	1785 W	N/A
Lowline /-40 VDC	N/A	800 W	1050 W	N/A	1050 W	1050 W	N/A
Highline 240 VDC	700 W	800 W	1100 W	N/A	1400 W	1400 W	1800 W
DC -48-60 V	N/A	N/A	N/A	1100 W	N/A	N/A	N/A

The PowerEdge R6615 supports up to two AC or DC power supplies with 1+1 redundancy, autosensing, and auto switching capability.

If two PSUs are present during POST, a comparison is made between the wattage capacities of the PSUs. In case the PSU wattages do not match, the larger of the two PSUs is enabled. Also, there is a PSU mismatch warning that is displayed in the BIOS, iDRAC, or on the System LCD.

If a second PSU is added at run-time, in order for that particular PSU to be enabled, the wattage capacity of the first PSU must equal the second PSU. Otherwise, the PSU is flagged as unmatched in iDRAC and the second PSU is not enabled.

Dell PSUs have achieved Platinum efficiency levels as shown in the table below.

Table 26. PSU Efficiency Levels

Efficiency Targets by Load						
Form factor	Output	Class	10%	20%	50%	100%
Redundant 60 mm	700 W AC	Titanium	90.00%	94.00%	96.00%	91.50%
	800 W AC	Platinum	89.00%	93.00%	94.00%	91.50%
	1100 W AC	Titanium	90.00%	94.00%	96.00%	91.50%
	1100 W -48 VDC	N/A	85.00%	90.00%	92.00%	90.00%
	1400 W AC	Platinum	89.00%	93.00%	94.00%	91.50%
	1400 W AC	Titanium	90.00%	94.00%	96.00%	91.50%
	1800 W AC	Titanium	90.00%	94.00%	96.00%	94.00%

Environmental specifications

NOTE: For additional information about environmental certifications, refer to the *Product Environmental Datasheet* located with the *Documentation* on [Dell Support](#).

Table 27. Continuous Operation Specifications for ASHRAE A2

Temperature	Specifications
Allowable operations	
Temperature range for altitudes <= 900 m (<= 2953 ft)	10 to 35°C (50 to 95°F) with no direct sunlight on the platform
Humidity percent range (non-condensing at all times)	8% RH with -12°C minimum dew point to 80% RH with 21°C (69.8°F) maximum dew point
Operational altitude de-rating	Maximum temperature is reduced by 1°C/300 m (1.8°F/984 Ft) above 900 m (2953 Ft)

Table 28. Continuous Operation Specifications for ASHRAE A3

Temperature	Specifications
Allowable operations	
Temperature range for altitudes <= 900 m (<= 2953 ft)	5 to 40°C (41 to 104°F) with no direct sunlight on the equipment
Humidity percent range (non-condensing at all times)	8% RH with -12°C minimum dew point to 85% RH with 24°C (75.2°F) maximum dew point
Operational altitude de-rating	Maximum temperature is reduced by 1°C/175 m (1.8°F/574 Ft) above 900 m (2953 Ft)

Table 29. Continuous Operation Specifications for ASHRAE A4

Temperature	Specifications
Allowable operations	
Temperature range for altitudes <= 900 m (<= 2953 ft)	5 to 45°C (41 to 113°F) with no direct sunlight on the equipment

Table 29. Continuous Operation Specifications for ASHRAE A4 (continued)

Temperature	Specifications
Humidity percent range (non-condensing at all times)	8% RH with -12°C minimum dew point to 90% RH with 24°C (75.2°F) maximum dew point
Operational altitude de-rating	Maximum temperature is reduced by 1°C/125 m (1.8°F/410 Ft) above 900 m (2953 Ft)

Table 30. Common Environmental Specifications

Allowable operations	
Maximum temperature gradient (applies to both operation and non-operation)	20°C in an hour* (36°F in an hour) and 5°C in 15 minutes (9°F in 15 minutes), 5°C in an hour* (9°F in an hour) for tape hardware <i>i</i> NOTE: * - Per ASHRAE thermal guidelines for tape hardware, these are not instantaneous rates of temperature change.
Non-operational temperature limits	-40 to 65°C (-40 to 149°F)
Non-operational humidity limits	5% to 95% RH with 27°C (80.6°F) maximum dew point
Maximum non-operational altitude	12,000 meters (39,370 feet)
Maximum operational altitude	3,050 meters (10,006 feet)

Table 31. Maximum vibration specifications

Maximum vibration	Specifications
Operating	0.21 G _{rms} at 5 Hz to 500 Hz for 10 minutes (all operation orientations)
Storage	1.88 G _{rms} at 10 Hz to 500 Hz for 15 minutes (all six sides tested)

Table 32. Maximum shock pulse specifications

Maximum shock pulse	Specifications
Operating	Six consecutively executed shock pulses in the positive and negative x, y, and z axis of 6 G for up to 11 ms
Storage	Six consecutively executed shock pulses in the positive and negative x, y, and z axis (one pulse on each side of the system) of 71 G for up to 2 ms

Particulate and gaseous contamination specifications

The following table defines the limitations that help avoid any equipment damage or failure from particulate and gaseous contamination. If the levels of particulate or gaseous pollution exceed the specified limitations and result in equipment damage or failure, you may need to rectify the environmental conditions. Remediation of environmental conditions is the responsibility of the customer.

Table 33. Particulate contamination specifications

Particulate contamination	Specifications
Air filtration	Data center air filtration as defined by ISO Class 8 per ISO 14644-1 with a 95% upper confidence limit <i>i</i> NOTE: This condition applies to data center environments only. Air filtration requirements do not apply to IT equipment designed to be used outside a data center, in environments such as an office or factory floor. <i>i</i> NOTE: Air entering the data center must have MERV11 or MERV13 filtration.

Table 33. Particulate contamination specifications (continued)

Particulate contamination	Specifications
Conductive dust	Air must be free of conductive dust, zinc whiskers, or other conductive particles <i>i</i> NOTE: This condition applies to data center and non-data center environments.
Corrosive dust	<ul style="list-style-type: none"> Air must be free of corrosive dust Residual dust present in the air must have a deliquescent point less than 60% relative humidity <i>i</i> NOTE: This condition applies to data center and non-data center environments.

Table 34. Gaseous contamination specifications

Gaseous contamination	Specifications
Copper coupon corrosion rate	<300 Å/month per Class G1 as defined by ANSI/ISA71.04-2013
Silver coupon corrosion rate	<200 Å/month as defined by ANSI/ISA71.04-2013

Cooling components

Table 35. Cooling components

Item	Type	Solution Strategy	
Fan	Standard Fan (STD)	All 3.5-inch HDD x 4 Configurations.	
	High Performance Gold Fan (HPR Gold)	for Air Cooling	for Liquid Cooling
Either one matched in non 3.5-inch Chassis: 2.5-inch x 10 configuration 2.5-inch x 8 and No BP configurations DDR5 RDIMM >128 GB Rear Drives GPU		3.5-inch HDD x 4 config. w/ LC part in QB DDR5 RDIMM >128 GB Rear Drives GPU	
CPU HSK	1U EXT. HSK.	All air cooling configurations.	
	DLC Module	For all CPU operation at DLC configurations.	
Shroud	Air Shroud	All air cooling configurations require an air shroud.	
	Air Shroud for 1DPC	New air shroud be required at all air cooling config. w/ 1DPC MB.	
	OCP Shroud	System with OCP card but without riser 2 implemented.	
Blank	DIMM Blank	When CPU > 240 W installed, except DLC configurations.	

Particulate and gaseous contamination specifications

The following table defines the limitations that help avoid any equipment damage or failure from particulates and gaseous contamination. If the levels of particulates or gaseous pollution exceed the specified limitations and result in equipment damage or failure, you must rectify the environmental conditions. Remediation of environmental conditions is the responsibility of the customer.

Table 36. Particulate contamination specifications

Particulate contamination	Specifications
Air filtration: Conventional Data Center only	<p>Data center air filtration as defined by ISO Class 8 per ISO 14644-1 with a 95% upper confidence limit</p> <p>i NOTE: Filtering room air with a MERV8 filter, as specified in ANSI/ASHRAE Standard 127, is a recommended method for achieving the necessary environmental conditions.</p> <p>i NOTE: Air entering the data center must have MERV11 or MERV13 filtration.</p> <p>i NOTE: This condition applies to data center environments only. Air filtration requirements do not apply to IT equipment designed to be used outside a data center, in environments such as an office or factory floor.</p>
Walk-Up Edge Data Center or Cabinet (sealed, closed loop environment)	<p>Filtration is not required for cabinets that are anticipated to be opened six times or less per year. Class 8 per ISO 1466-1 filtration as defined above is required otherwise.</p> <p>i NOTE: In environments commonly above ISA-71 Class G1 or that may have known challenges, special filters may be required.</p>
Conductive dust: data center and non-data center environments	<p>Air must be free of conductive dust, zinc whiskers, or other conductive particles.</p> <p>i NOTE: Conductive dust, which can interfere with equipment operation, can originate from various sources, including manufacturing processes and zinc whiskers that may develop on the plating of raised floor tiles.</p> <p>i NOTE: This condition applies to data center and non-data center environments.</p>
Corrosive dust: data center and non-data center environments	<ul style="list-style-type: none"> • Air must be free of corrosive dust. • Residual dust present in the air must have a deliquescent point less than 60% relative humidity. <p>i NOTE: This condition applies to data center and non-data center environments.</p>

Table 37. Gaseous contamination specifications

Gaseous contamination	Specifications	Notes
Copper coupon corrosion rate	ISA-71 Class G1: <300 Å/month	Per ANSI/ISA71.04
Silver coupon corrosion rate	ISA-71 Class G1: <200 Å/month	Per ANSI/ISA71.04

Thermal restriction matrix

Table 38. Label reference

Label	Description
STD	Standard performance
HPR Gold	High performance (gold grade)
EXT. HSK.	External Heat sink
LP	Low profile
FH	Full height
DLC	Direct liquid cooling

Table 39. Air cooling: Thermal restriction matrix (non-GPU)

Configuration				No BP	8 x 2.5-inch U.2	4 x 3.5-inch		10 x 2.5-inch SAS			10 x 2.5-inch NVMe		16 x E3.S 14 x E3.S	
Rear storage				No Rear Drives	No Rear Drives	No Rear Drives	E3.S x 2	No Rear Drives	2.5-inch SAS x 2	E3.S x 2	No Rear Drives	E3.S x 2	No Rear Drives	
cTDP	Model	Core Count												
CPU TDP/ cTDP	240 W	9334	32	35°C	35°C	35°C	30°C	35°C	35°C	35°C	35°C	35°C	35°C	
	240 W	9224	24	35°C	35°C	35°C	30°C	35°C	35°C	35°C	35°C	35°C	35°C	
	240 W	9254	24	35°C	35°C	35°C	30°C	35°C	35°C	35°C	35°C	35°C	35°C	
	240 W	9124	16	35°C	35°C	35°C	30°C	35°C	35°C	35°C	35°C	35°C	35°C	
	300 W	9634	84	35°C	35°C	Not Supported	Not Supported	30°C	30°C	30°C	30°C	30°C	30°C	
	300 W	9534	64	35°C	35°C			30°C	30°C	30°C	30°C	30°C	30°C	30°C
	300 W	9454/ 9454P	48	35°C	35°C			30°C	30°C	30°C	30°C	30°C	30°C	30°C
	300 W	9354/ 9354P	32	35°C	35°C			30°C	30°C	30°C	30°C	30°C	30°C	30°C
	400 W	9654/ 9654P	96	30°C	30°C	Not Supported	Not Supported	Require DLC	Not Supported	Not Supported	Not Supported	Not Supported	Not Supported	Not Supported
	400 W	9554/ 9554P	64	Require DLC										
	400 W	9474F	48	Require DLC										
	400 W	9374F	32	30°C	30°C									
	400 W	9274F	21	30°C	30°C									
	400 W	9174F	16	30°C	30°C									
	400 W	9754	128	Require DLC										
	400 W	9734	112	30°C	30°C									
	400 W	9684X	96	Require DLC										
	400 W	9384X	32	30°C	30°C									
400 W	9184X	16	30°C	30°C										
Memory	16 GB RDIMM			35°C	35°C									
	32 GB RDIMM			35°C	35°C	35°C	35°C	35°C	35°C	35°C	35°C	35°C	35°C	
	64 GB RDIMM			35°C	35°C	35°C	35°C	35°C	35°C	35°C	35°C	35°C	35°C	

Table 39. Air cooling: Thermal restriction matrix (non-GPU) (continued)

Configuration			No BP	8 x 2.5-inch U.2	4 x 3.5-inch		10 x 2.5-inch SAS			10 x 2.5-inch NVMe		16 x E3.S 14 x E3.S
Rear storage			No Rear Drives	No Rear Drives	No Rear Drives	E3.S x 2	No Rear Drives	2.5-inch SAS x 2	E3.S x 2	No Rear Drives	E3.S x 2	No Rear Drives
cTDP	Model	Core Count										
	96 GB RDIMM		35°C	35°C	35°C	35°C	35°C	35°C	35°C	35°C	35°C	35°C
	128 GB RDIMM		35°C	35°C	35°C	30°C	35°C	35°C	35°C	35°C	35°C	35°C
	256 GB RDIMM		35°C	35°C	30°C	Not Supported	35°C	30°C	30°C	35°C	30°C	35°C

Table 40. Air cooling: Thermal restriction matrix (GPU Configuration)

Configuration		No BP	8 x 2.5-inch U.2	4 x 3.5-inch		10 x 2.5-inch	16 x E3.S 14 x E3.S
Rear storage		No Rear Drives	No Rear Drives	No Rear Drives		No Rear Drives	No Rear Drives
cTDP							
CPU TDP/ cTDP	240 W	Not Supported	35°C	30°C		35°C	35°C
	300 W		30°C	Not Supported		30°C	30°C
	400 W		Not Supported				
Memory	16 GB RDIMM		35°C	30°C		35°C	35°C
	32 GB RDIMM		35°C	30°C		35°C	35°C
	64 GB RDIMM		35°C	30°C		35°C	35°C
	96 GB RDIMM		35°C	30°C		35°C	35°C
	128 GB RDIMM	35°C	30°C		35°C	35°C	
256 GB RDIMM	35°C	30°C		35°C	35°C		

NOTE: For fan type selection, refer the solution strategy under cooling components.

Thermal air restrictions

Table 41. ASHRAE A3/A4 environment - Air cooling

ASHRAE	ASHRAE A3/40°C	ASHRAE A4/45°C
Front Storage	3.5" config. is not supported 2.5" x 10 is not supported NVME not supported E3.S config. is not supported	

Table 41. ASHRAE A3/A4 environment - Air cooling (continued)

ASHRAE	ASHRAE A3/40°C	ASHRAE A4/45°C
Fan type	HPR Gold fans are required	
CPU	CPU TDP > 240 W are not supported	CPU TDP > 200 W are not supported
Memory	128 GB and higher capacity RDIMMS are not supported.	
PCIe card	Non-Dell qualified peripheral cards and consuming power greater than 25 W are not supported	
GPU	GPU cards are not supported	
Rear storage	Not Supported	
OCP	Support with 85C active optic cable	Not Supported
PSU	Two PSUs are required in redundant mode. System performance may be reduced in the event of a PSU failure	
BOSS-N1	Supported	Not Supported

Table 42. ASHRAE A3/A4 environment - Liquid cooling

ASHRAE	ASHRAE A3/40°C	ASHRAE A4/45°C
Front Storage	3.5" config. is not supported NVMe is not supported E3.S config. is not supported	
Fan type	HPR Gold fans are required	
Memory	128 GB and higher capacity RDIMMS are not supported.	
PCIe card	Non-Dell qualified peripheral cards and consuming power greater than 25 W are not supported	
GPU	GPU cards are not supported	
Rear storage	Not Supported	
OCP	Support with 85C active optic cable	Not Supported
PSU	Two PSUs are required in redundant mode. System performance may be reduced in the event of a PSU failure	
BOSS-N1	Supported	Not Supported

Appendix B. Standards compliance

The system conforms to the following industry standards.

Table 43. Industry standard documents

Standard	URL for information and specifications
ACPI Advance Configuration and Power Interface Specification, v6.4	ACPI
Ethernet IEEE Std 802.3-2022	IEEE Standards
MSFT WHQL Microsoft Windows Hardware Quality Labs	Windows Hardware Compatibility Program
IPMI Intelligent Platform Management Interface, v2.0	IPMI
DDR5 Memory DDR5 SDRAM Specification	JEDEC Standards
PCI Express PCI Express Base Specification, v5.0	PCIe Specifications
PMBus Power System Management Protocol Specification, v1.2	Power System Management Protocol Specification
SAS Serial Attached SCSI, 3 (SAS-3) (T10/INCITS 519)	SCSI Storage Interfaces
SATA Serial ATA Rev. 3.3	SATA IO
SMBIOS System Management BIOS Reference Specification, v3.3.0	DMTF SMBIOS
TPM Trusted Platform Module Specification, v1.2 and v2.0	TPM Specifications
UEFI Unified Extensible Firmware Interface Specification, v2.7	UEFI Specifications
PI Platform Initialization Specification, v1.7	
USB Universal Serial Bus v2.0 and SuperSpeed v3.0 (USB 3.1 Gen1)	USB Implementers Forum, Inc. USB
NVMe Express Base Specification. Revision 2.0c	NVMe
NVMe Command Set Specifications	
1. NVMe Express NVMe Command Set Specification. Revision 1.1c	
2. NVMe Express Zoned Namespaces Command Set. Revision 1.0c	
3. NVMe Express® Key Value Command Set. Revision 1.0c	
NVMe Transport Specifications	
1. NVMe Express over PCIe Transport. Revision 1.0c	
2. NVMe Express RDMA Transport Revision. 1.0b	
3. NVMe Express TCP Transport. Revision 1.0c	
NVMe NVMe Express Management Interface. Revision 1.2c	
NVMe NVMe Boot Specification. Revision 1.0	

Appendix C Additional resources

Table 44. Additional resources

Resource	Description of contents	Location
Installation and Service Manual	<p>This manual, available in PDF format, provides the following information:</p> <ul style="list-style-type: none"> • Chassis features • System Setup program • System indicator codes • System BIOS • Remove and replace procedures • Diagnostics • Jumpers and connectors 	Dell.com/Support/Manuals
Getting Started Guide	<p>This guide ships with the system, and is also available in PDF format. This guide provides the following information:</p> <ul style="list-style-type: none"> • Initial setup steps 	Dell.com/Support/Manuals
Rack Installation Guide	<p>This document ships with the rack kits, and provides instructions for installing a server in a rack.</p>	Dell.com/Support/Manuals
System Information Label	<p>The system information label documents the system board layout and system jumper settings. Text is minimized due to space limitations and translation considerations. The label size is standardized across platforms.</p>	Inside the system chassis cover
QR code for system resources	<p>This code on the chassis can be scanned by a phone application to access additional information and resources for the server, including videos, reference materials, service tag information, and Dell contact information.</p>	Inside the system chassis cover
Enterprise Infrastructure Planning Tool (EIPT)	<p>The Dell online EIPT enables easier and more meaningful estimates to help you determine the most efficient configuration possible. Use EIPT to calculate the power consumption of your hardware, power infrastructure, and storage.</p>	Dell.com/calc

Appendix D: Service and support

Topics:

- [Why attach service contracts](#)
- [ProSupport Infrastructure Suite](#)
- [Specialty Support Services](#)
- [ProDeploy Infrastructure Suite](#)
- [Supplemental Deployment Services](#)
- [Unique Deployment Scenarios](#)
- [DAY 2 – Automation Services with Ansible](#)
- [Dell Technologies Consulting Services](#)

Why attach service contracts

Dell PowerEdge servers include a standard hardware warranty that highlights our commitment to product quality by guaranteeing repair or replacement of defective components. While industry-leading, our warranties are limited to 1 or 3 years, depending on model, and do not cover software assistance. Call records show that failure rates for servers are roughly 1% and more commonly, customers seek Dell technical support for software-related issues like configuration guidance, troubleshooting, upgrade assistance, or performance tuning. Encourage customers to purchase ProSupport service contracts to supplement warranty coverage and ensure optimal support for both hardware and software. ProSupport provides a complete hardware guarantee beyond the original warranty period (up to 12 years: including seven years standard support and an additional five years of Post-Standard Support). Details of the ProSupport Suite and benefits are listed below.

ProSupport Infrastructure Suite

ProSupport Infrastructure Suite is a set of support services that enable customers to build the solution that is right for their organization. It is an industry-leading, enterprise-class support that aligns with the criticality of your systems, the complexity of your environment, and the allocation of your IT resources.

ProSupport Infrastructure Suite | Enhanced value across all offers!

	Basic Hardware Support	ProSupport for Infrastructure	ProSupport Plus for Infrastructure	Changes with August 2023 release
Technical support availability and response objective	9/5, immediate	24/7, immediate	24/7, immediate	No change
Covered products	Hardware	Hardware & Software	Hardware & Software	No change
Onsite response service level	NBD	NBD or 4-hour	4-hour	ProSupport Plus NBD is retired
ProSupport AIOps platforms	●	●	●	MyService360 and TechDirect (all offers) CloudIQ (ProSupport & ProSupport Plus)
Dell Security Advisories	●	●	●	Available on additional products
Proactive issue detection with automated case creation	●	●	●	New to Basic
Predictive hardware anomaly detection		●	●	New to ProSupport
Access to software updates		●	●	No change
CloudIQ health and cybersecurity monitoring & analytics		●	●	Enhanced features
Incident Manager for Severity 1 cases		●	●	No change
Mission Critical support			●	Enhanced features
Priority access to remote senior support engineers ¹			●	No change
Service Account Manager			●	No change
Proactive system maintenance			●	No change
Limited 3 rd party software support ²			●	No change

¹Based on availability

²Software license can be purchased through Dell or BYOL - see Service Descriptions for details.

DELL Technologies

Figure 45. ProSupport Enterprise Suite

ProSupport Plus for Infrastructure

ProSupport Plus for Infrastructure is the ultimate solution for customers seeking preventative maintenance and optimal performance on their business-critical assets. The service caters to customers who require proactive, predictive, and personalized support for systems that manage critical business applications and workloads. When customers purchase PowerEdge server, we recommend ProSupport Plus, our proactive and preventative support service for business-critical systems. ProSupport Plus provides all the benefits of ProSupport, including the following “Top five reasons to buy ProSupport Plus (PSP)”

- 1. Priority access to specialized support experts:** Immediate, advanced troubleshooting from an engineer that understands Dell infrastructure solutions.
- 2. Mission Critical Support:** When critical (Severity 1) support issues happen, the customer is assured that we do all that we can to get them back up and running as quickly as possible.
- 3. Service Account Manager:** A customer’s #1 support advocate, ensuring they get the best possible proactive and predictive support experience.
- 4. Systems maintenance:** On a semiannual basis, we will keep a customer’s ProSupport Plus system(s) up to date by installing the latest firmware, BIOS, and driver updates to improve performance and availability.
- 5. Third-party software support:** Dell is a customer’s single point of accountability for any eligible third-party software that is installed on their ProSupport Plus system, whether they purchased the software from us or not.

ProSupport for Infrastructure

Comprehensive 24x7 support for hardware and software – best for production, but not critical, workloads and applications. The ProSupport service offers highly trained experts around the clock and around the globe to address IT needs. We help minimize disruptions and maximize availability of PowerEdge server workloads with:

- 24x7 support through phone, chat and online
- A central point of accountability for all hardware and software issues
- Hypervisor, operating system and application support
- Dell security advisories
- Onsite response service levels 4 hour or Next Business Day options
- Proactive issue detection with automated case creation

- Predictive hardware anomaly detection
- Incident Manager assigned for Severity 1 cases
- Collaborative third-party support
- Access to AIOps Platforms - (MyService360, TechDirect, and CloudIQ)
- Consistent experience regardless of where customers are located or what language that they speak.

Basic Hardware Support

Provides reactive hardware support during normal business hours, excluding local national holidays. No software support or software-related guidance. For improved levels of support, choose ProSupport or ProSupport Plus.

Specialty Support Services

Optional specialty support services complement the ProSupport Infrastructure Suite to provide additional proficiencies that are critical for modern data center operations.

Hardware coverage add-ons to ProSupport

- **Keep Your Hard Drive (KYHD), Keep Your Component (KYC), or Keep Your GPU:**

Normally if a device fails under warranty, Dell replaces it using a one-for-one exchange process. KYHD/KYCC/KYGPU gives you the option to retain your device. It provides full control of sensitive data and minimizes security risk by letting you retain possession of failed drives, components, or GPU when receiving replacement parts without incurring additional cost.

- **Onsite Diagnosis Service:**

Ideal for sites with non-technical staff. Dell field technician performs initial troubleshooting diagnosis onsite and transfers to Dell remote engineers to resolve the issue.

- **ProSupport Add-on for HPC:**

Sold as an add-on to a ProSupport service contract, the ProSupport Add-on for HPC provides solution-aware support to cover the additional requirements that are required to maintain an HPC environment such as:

- Access to senior HPC experts
- Advanced HPC cluster assistance: performance, interoperability, and configuration
- Enhanced HPC solution level end-to-end support
- Remote pre-support engagement with HPC Specialists during ProDeploy implementation

- **ProSupport Add-on for Telco (Respond & Restore):**

An add-on service designed for the top 31 TELCO customers globally, Respond & Restore provides direct access to Dell solution experts who specialize in TELCO carrier-grade support. This add-on also provides a hardware uptime guarantee, meaning if a system fails, Dell has it installed and operational within 4 hours for Severity 1 issues. Dell incurs penalties and fees if SLAs are not met.

Personalized Support and Supplemental Site-wide Expertise

- **Technical Account Manager:**

Designated technology lead who monitors and manages the performance and configuration of specific technology sets.

- **Designated Remote Support:**

Personalized support expert who manages all troubleshooting and resolution of IT assets.

- **Multivendor Support Service:**

Support your third-party devices as one service plan for servers, storage, and networking (includes coverage for: Broadcom, Cisco, Fujitsu, HPE, Hitachi, Huawei, IBM, Lenovo, NetApp, Oracle, Quanta, SuperMicro and others).

Services for large enterprises

- **ProSupport One for Data Center:**

ProSupport One for Data Center offers flexible site-wide support for large and distributed data centers with more than 1,000 assets (combined total of server, storage, networking, so forth). This offering is built on standard ProSupport features that leverage our global scale and are tailored to specific customer needs. While not for everyone, this service option offers a truly unique solution for our largest customers with the most complex environments.

- Team of assigned Services Account Managers with remote or onsite options
- Assigned technical and field engineers who are trained on the customer's environment and configurations.
- On-demand reporting and recommendations that are enabled by ProSupport AIOps tools (MyService360, TechDirect, and CloudIQ)
- Flexible onsite support and parts options that fit their operational model
- A tailored support plan and training for their operations staff

- **ProSupport One for CSPs (Cloud Serviced Providers)**

ProSupport One for CSPs is a unique offer that is designed for a limited set of Dell accounts purchasing Gen AI computing solutions greater than 1,000 servers and \$250M in sales. PS1 for CSPs improves the entire services experience combining support, deployment (rack integration), residency services, a designated support engineer and the LOIS parts locker as one holistic bundle. Special pricing has been determined to compete effectively against competitors and provide the best customer experience. PS1 for CSPs can only be sold with XE Servers and all networking platforms (Dell and NVIDIA). All other products would be eligible for the standard PS1DC not this special bundle offer. More details on PS1 for CSPs [here](#).

- **Logistics Online Inventory Solution (LOIS)**

Ideal for large organizations that have their own staff to support their data center. Dell offers a service that is called Logistics Online Inventory Solution which is an onsite parts locker that provides self-maintainers with a local inventory of common replacement components. Having access to these parts lockers allows the self-maintainer to replace a failed component immediately without delay. Each replacement part would automatically initiate a replenishment of the parts inventory that is shipped the next day or delivered onsite by Dell during a regular scheduled visit (called Scheduled Onsite Service). As part of the LOIS system, customers can integrate their systems directly to Dell TechDirect using APIs to help streamline the support management process.

End-of-Life Services

- **Post Standard Support (PSS)**

Extend service life beyond the initial seven years of ProSupport, adding up to five more additional years of hardware coverage.

- **Data Sanitization & Data Destruction**

Renders data unrecoverable on repurposed or retired products, ensuring security of sensitive data and enabling compliance and provides NIST-compliant certification.

- **Asset Recovery Services**

Recycle, resale, and disposal of hardware. Helps you securely and responsibly retire IT assets that are no longer needed while protecting both your business and the planet.

ProDeploy Infrastructure Suite

ProDeploy Infrastructure Suite provides various deployment offerings that satisfy a customer's unique needs. It is made up of 5 offers: ProDeploy Configuration Services, ProDeploy Rack Integration Services, Basic Deployment, ProDeploy, and ProDeploy Plus.

ProDeploy Infrastructure Suite

Versatile choices for accelerated deployments

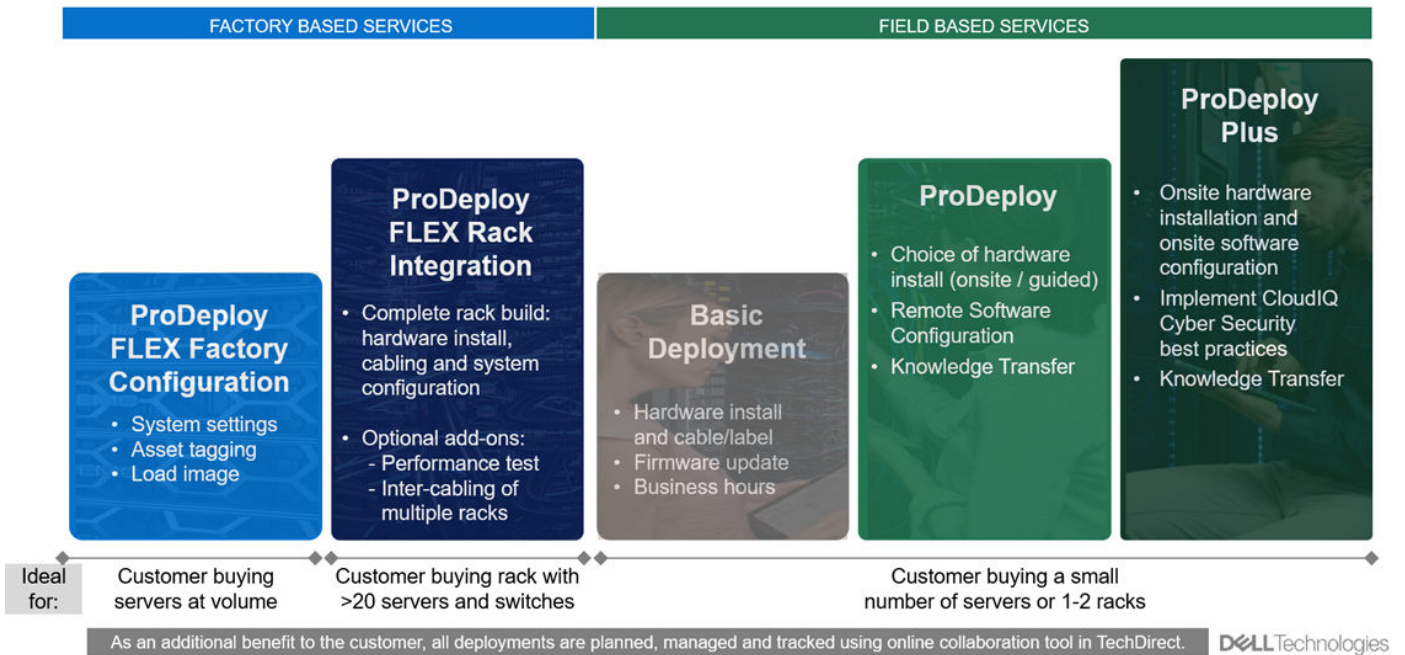

Figure 46. ProDeploy Infrastructure Suite

Factory-based Services

The new Factory Services consist of two tiers of deployment that happen prior to shipping to the Customer's site.

ProDeploy FLEX Factory Configuration

Ideal for Customers buying servers in volume and seeking pre-configuration prior to shipping such as: custom image, system settings, and asset tagging so it arrives ready to use out of the box. Furthermore, servers are packaged and bundled to meet specific shipping and distribution requirements for each customer location to facilitate the rollout process. Once the server is onsite, Dell can install and configure the server to the environment using any of the field-based deployment services outlined in the next section.

ProDeploy FLEX Rack Integration

Ideal for customers seeking to build out fully integrated racks prior to shipping. These rack builds include hardware install, cabling, and full system configuration. You can also add-on a factory stress test and optional on-site final rack configuration to complete the rack installation.

- STANDARD SKUs for Rack Integration is available in USA only and requires:
 - 20 or more devices (R and C series servers, VxRail, and all Dell or non-Dell switches.
 - Shipping to contiguous USA.
- USE CUSTOM QUOTE for Rack Integration scenarios that require:
 - Shipment to any country or region outside USA or shipping outside contiguous USA
 - Shipping to multiple locations
 - Racks containing fewer than 20 servers
 - Any rack that includes Storage.

ProDeploy Flex | Modular deployment (built in factory, onsite or remote)

Pre -deployment	Single point of contact for project management	●
	Expanded end-to-end project management	Selectable
	Site readiness review and implementation planning	●
Deployment	Deployment service hours	24/7
	Hardware installation options ¹	Onsite, factory ^{2,5} or remote ³
	System software installation and configuration options ¹	Onsite, factory ^{2,5} or remote ³
	Multivendor networking deployment ⁴	Onsite, factory ^{2,5} or remote ³
	Onsite Deployment in remote locations	Selectable
	Onsite Deployment in challenging environments	Selectable
	Onsite Deployment with special site-based protocols or requirements	Selectable
	Install connectivity software based on Secure Connect Gateway technology	●
	Dell NativeEdge Orchestrator deployment	Selectable
	Configure 3 rd party software applications and workloads ⁴	Selectable
Post -deployment	Deployment verification, documentation, and knowledge transfer	●
	Configuration data transfer to Dell support	●
Online collaboration	Online collaborative environment - Planning, managing and tracking delivery process	●

¹ Hardware and Software delivery methods can be independently chosen; selecting Rack integration for software requires hardware Rack integration to also be selected.

² Factory Rack Integration for server and VxRail; includes associated Dell network switches; final onsite rack installation available.

³ Remote hardware option includes project specific instructions, documentation and live expert guidance for hardware installation.

⁴ Select 3rd party multivendor networking and software applications.

⁵ Pair with Field Onsite Hardware service for final installation.

Figure 47. ProDeploy Flex modular services

Field-based services

- **ProDeploy Plus:**

Elevate Infrastructure deployments with our most complete service from planning through onsite hardware installation and software configuration including the implementation of cybersecurity best practices. ProDeploy Plus provides the skill and scale that is needed to successfully perform demanding deployments in today's complex IT environments. The deployment starts with a site readiness review and implementation plan. Certified deployment experts perform the software configuration to include setup of leading operating systems and hypervisors. Dell will also configure PowerEdge software tools to include iDRAC and OpenManage system utilities and support AIOps platforms: MyService360, TechDirect, and CloudIQ. Unique to ProDeploy Plus, the cybersecurity implementation helps customers understand potential security risks and make recommendations for reducing product attack surfaces. The system is tested, validated prior to completion. The customer will also receive full project documentation and knowledge transfer to complete the process.

- **ProDeploy:**

ProDeploy provides remote software configuration and choice of hardware installation (onsite or guided). ProDeploy is great for customers who are price sensitive or willing to participate in some portion of the deployment to include providing remote access to their network. The ProDeploy remote software implementation includes everything that is mentioned in ProDeploy Plus except it does not include the added value, cybersecurity implementation and best practices.

ProDeploy Infrastructure Suite | Field services

		Basic Deployment	ProDeploy	ProDeploy Plus
Pre-deployment	Single point of contact for project management	-	●	In region
	Site readiness review and implementation planning	-	●	●
Deployment	Deployment service hours	Business hours	24/7	24/7
	Hardware installation options	Onsite	Onsite or guided ¹	Onsite
	System software installation and configuration options	-	Remote	Onsite
	Install connectivity software based on Secure Connect Gateway technology ²	-	●	●
	Implement CyberSecurity best practices and policies in APEX AIOps Infrastructure Observability	-	-	●
Post-deployment	Deployment verification, documentation and knowledge transfer	-	●	●
	Configuration data transfer to Dell technical support	-	●	●
Online collaboration	Online collaborative platform in TechDirect for planning, managing and tracking delivery	-	●	●

¹ Choose from onsite hardware installation or a guided option including project specific instructions, documentation and live expert guidance

² Post deployment use for intelligent, automated support & insights

Figure 48. ProDeploy Infrastructure Suite - Field services

Supplemental Deployment Services

Additional ways to expand scope or deploy for unique scenarios.

Two Host Adder (requires PD/PDP)

Deploying new storage, compute, or networking devices may require interconnection to other servers (also called hosts). The Dell delivery team will set up four hosts per device as part of every ProDeploy service. For example, if the customer is buying two storage arrays the ProDeploy service will automatically include connectivity of four hosts each (4x2=8 total hosts per project since there are two devices). This supplemental "Two Host Adder" service provides for the configuration of additional hosts above what is already provided as part of the ProDeploy service. In many cases, customers can work with us while we set up the included hosts, so they may understand how to do the rest themselves. Always ask the customer how many hosts are being connected and sell the host adder depending on the customer's technology skillset. Note that this service applies to the connectivity of Dell devices not 3rd party devices.

Additional Deployment Services (ADT) – sold with or without PD/PDP

You can expand the scope of a ProDeploy engagement leveraging Additional Deployment Time (ADT). ADT covers additional tasks above the normal deliverables of the ProDeploy offers. ADT can also be used as a standalone service without ProDeploy. SKUs are available for both Project Management and Technical Resource Expertise. SKUs are sold as blocks of four hours remote or eight hours onsite. The delivery team can help in scoping the number of hours required for additional tasks.

Data Migration Services

Migrating data sets is no easy task. Our experts use proven tools and process to streamline data migrations and avoid compromising data. A customer project manager works with our experienced team of experts to create a migration plan. Data migration is part of every technology upgrade, platform change, and shift to the cloud. You can rely on Dell data migration services to perform a seamless transition.

Residency Services

Certified technical professionals act like an extension of your IT staff to enhance internal capabilities and resources and help you realize faster adoption and maximized ROI of new technology. Residency Services help customers transition to new capabilities quickly by leveraging specific technology skill sets. Residency experts can provide post implementation management and knowledge transfer that is related to a new technology acquisition or day-to-day operational management of the IT infrastructure.

- Global experts available to serve in-person (onsite) or virtual (remote)
- Engagements starting at 2 weeks with flexibility to adjust
- Residency is available for project management needs, and many different technology skills sets such as: Server, storage, Gen AI, networking, security, multi-cloud, data mgmt., and modern workforce application residents

Unique Deployment Scenarios

Custom Deployment Services

When a deployment is beyond the scope of the ProDeploy Infrastructure Suite, you can turn to the custom deployment services team to address complex implementation scenarios and customer unique requirements. The Dell custom deployment team is staffed with solution architects who will assist with customer scoping calls to define the project and develop the statement of work. Custom services can handle a wide range of deployments that can be performed in the factory or onsite. All custom engagement services are requested through SFDC.

ProDeploy FLEX

ProDeploy Flex is a modular service and a powerful tool for you to attach more services and improve revenue and margins. The ProDeploy Flex modular offer allows sales teams to build and better tailor services by mixing factory and field delivery options. You can also select special deployment scenarios without going to the custom order desk. FLEX is ideal for unique deployments where ProDeploy or ProDeploy Plus are not an adequate answer to the customer needs. Key features of ProDeploy FLEX :

- Build deployment quotes using modular, selectable features for both hardware and software.
- The system automatically scales pricing based on volume.
- Ideal for customers who require NativeEdge Orchestrator or edge deployments.
- Ability to add deployment services to third-party networking devices.

Deployment of HPC

High-Performance Computing (HPC) implementations require specialists that understand advanced feature sets. Dell deploys the world 's fastest systems and understands the nuances that make them perform. HPC deployments are most often scoped as custom service engagements, however we can do smaller HPC clusters under 300 nodes using a standard ProDeploy SKU. Any standard SKU for HPC deployment will be sold as one base SKU per cluster (ProDeploy for HPC Base) along with one ProDeploy for HPC Add-on for each device in the cluster (server nodes and switches).

Scope of ProDeploy for HPC:

 **NOTE:** Available as standard SKUs in US and Canada. Custom Service would be required for all other regions.

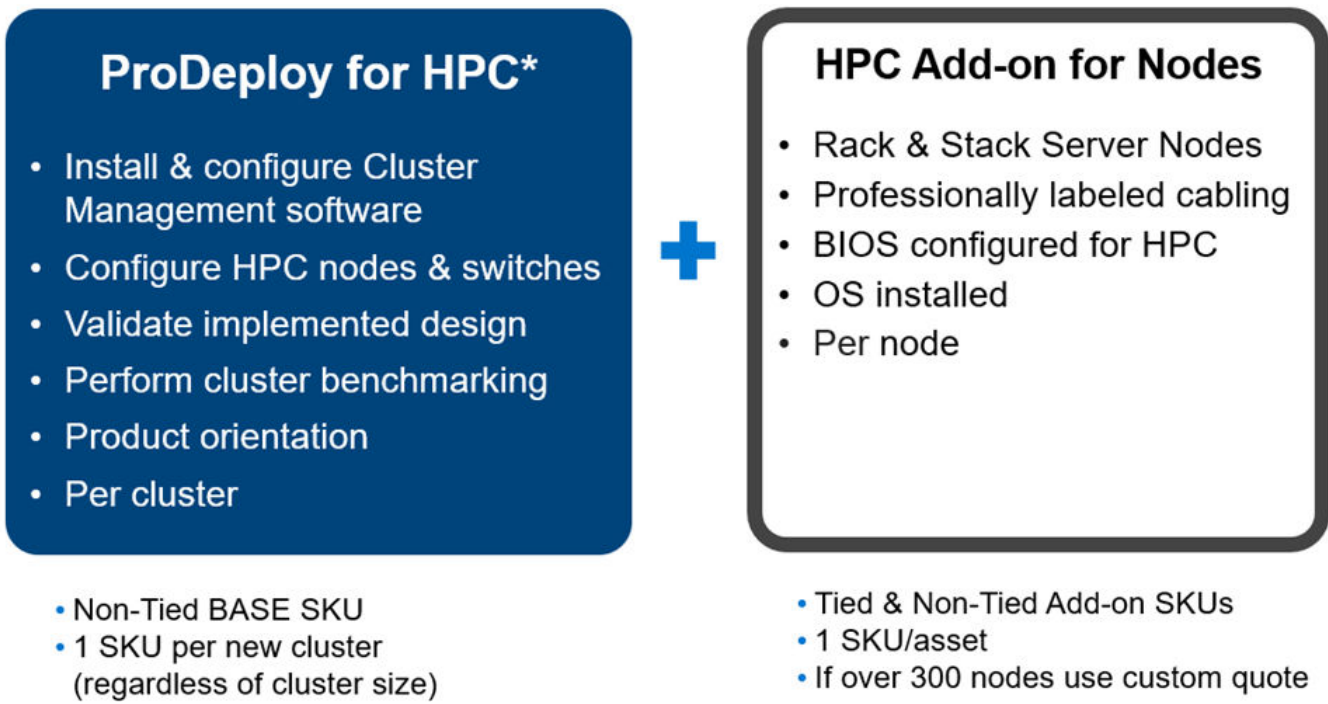
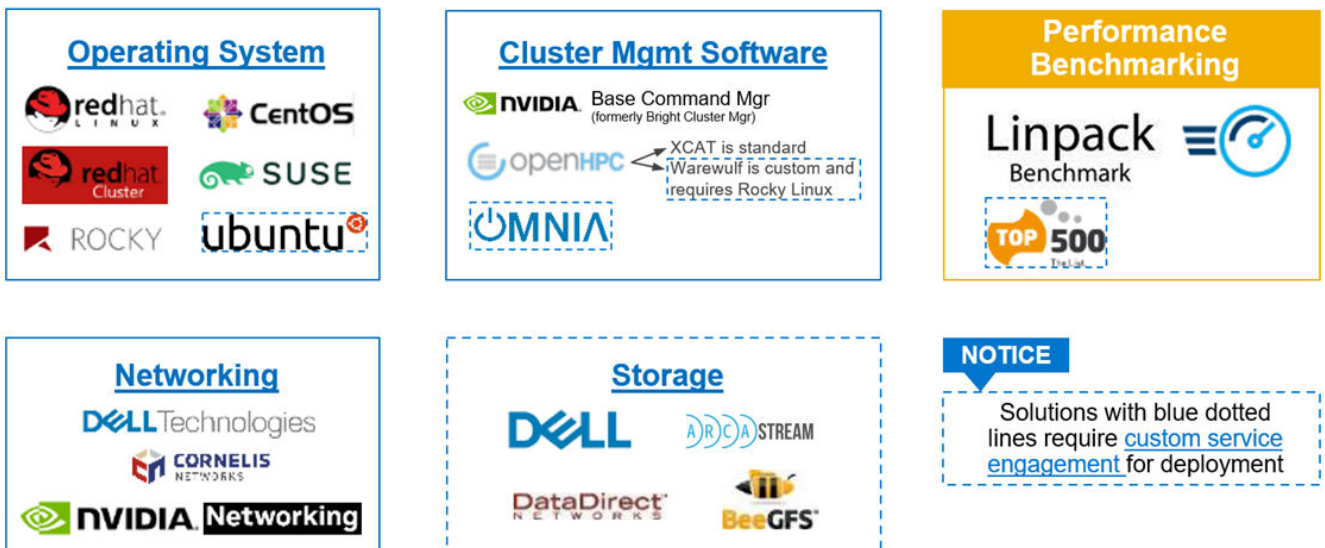

Figure 49. Standard deliverables of ProDeploy for HPC

Build HPC solutions for your unique requirements

Choose ProDeploy for HPC or Custom deploy

ProDeploy service includes configuration of most OS, cluster mgmt., networking and benchmarking



Notes related to networking above: Omni-Path is no longer an Intel Product, but is now distributed by a company called Cornelis, and Mellanox was purchased by Nvidia, and now goes by Nvidia Networking.

Figure 50. Visual view of HPC deployment options to include hardware and software

DAY 2 – Automation Services with Ansible

Dell solutions are built as “automation ready” with integrated APIs (Application Programming Interfaces) to allow customers to programmatically call actions on the product through code. Although Dell has published Anisble automation use cases, some customers need additional assistance with GitOps. By the end of the service, the customer will have the foundational

components required to accelerate automation and understand how the programming works together: Day 1 and Day 2 use case automation scripts (ansible modules), CI/CD tool (Jenkins), and Version control (Git).

Dell Technologies Consulting Services

Our expert consultants help customers transform faster, and quickly achieve business outcomes for the high value workloads Dell PowerEdge systems can handle. From strategy to full-scale implementation, Dell Technologies Consulting can help determine how to perform IT, workforce, or application transformation. We use prescriptive approaches and proven methodologies that are combined with portfolio and partner ecosystem of Dell Technologies to help achieve real business outcomes. From multi cloud, applications, DevOps, and infrastructure transformations, to business resiliency, data center modernization, analytics, workforce collaboration, and user experiences-we are here to help.

Dell Managed Services

Some customers prefer Dell to manage the complexity and risk of daily IT operations, Dell Managed Services utilizes proactive, AI enabled delivery operations and modern automation to help customers realize desired business outcomes from their infrastructure investments. With these technologies, our experts run, update and fine-tune customer environments aligned with service levels, while providing environment-wide and down-to-the-device visibility. There are two types of managed service offers. First the outsourcing model or CAPEX model where Dell manages the customer owned assets using our people and tools. The second is the as-a-Service model or OPEX model called APEX. In this service, Dell owns all technology and all the management of it. Many customers will have a blend of the two management types depending on the goals of the organization.

Managed	Outsourcing or CAPEX model	APEX	as-a-Service or OPEX model
<p>We manage your technology using our people and tools.¹</p> <ul style="list-style-type: none"> • Managed detection and response* • Technology Infrastructure • End-user (PC/desktop) • Service desk operations • Cloud Managed (Pub/Private) • Office365 or Microsoft Endpoint 		<p>We own all technology so you can off-load all IT decisions.</p> <ul style="list-style-type: none"> • APEX Cloud Services • APEX Flex on Demand elastic capacity • APEX Data Center Utility pay-per-use model 	

1 – Some minimum device counts may apply. Order via: ClientManagedServices.sales@dell.com

* Managed detection and response covers the security monitoring of laptops, servers, & virtual servers. Min. 50 devices combined. No Networking or Storage-only systems [SAN/NAS]. Available in 32 countries. [Details here](#)

Figure 51. Dell Managed Services

Managed Detection and Response (MDR)

Dell Technologies Managed Detection and Response (MDR) is powered by Secureworks Taegis XDR software platform. MDR is a managed service that secures the customer’s IT environment against malicious actors and provides remediation if and when a threat is identified. When a customer purchases MDR, they will receive the following features from our team:

- Dell badge resources
- Agent rollout assistance to help deploy the Secureworks Endpoint Agent
- 24x7 threat detection & investigation
- Up to 40hrs per quarter of response and active remediation activities
- If the customer experiences a breach, we will provide up to 40hrs per year of Cyber incident response initiation
- Quarterly reviews with the customer to review the data

Dell Technologies Education Services

Build the IT skills required to influence the transformational outcomes of the business. Enable talent and empower teams with the right skills to lead and perform transformational strategy that drives competitive advantage. Leverage the training and certification required for real transformation.

Dell Technologies Education Services offers PowerEdge server training and certifications that are designed to help customers achieve more from their hardware investment. The curriculum delivers the information and the practical, firsthand skills that their team must confidently install, configure, manage, and troubleshoot Dell servers.

To learn more or register for a class today, see [Education.Dell.com](https://www.dell.com/education).